



# STERO ER-66S

## RACK CONVEYOR SERIES



The **STERO ER-66S** starts with our ER-44 and adds a powerful 22" Scrapper. The ER-66S is ENERGY STAR® Qualified featuring a power scrapper, power wash followed by a sanitizing 180° final rinse, creating a high volume, low water consuming washer in a 66" footprint.

The full rack width washing pattern with our 225 gallons per minute pump powers this dishwashing workhorse. Rinsing and sanitizing is controlled by STERO's exclusive rack activated final rinse which guarantees accurate, trouble free cleaning.

Easy to operate, accessibility to components for maintenance and a basic design that produces clean dishes... that is the **STERO ER-66S** conveyor.

### STANDARD FEATURES

- 223 racks per hour
- Rinse 2.43 gpm/.52 gallons per rack
- 21" opening accepts most ware
- Automatic fill maintains proper tank levels
- Automatic start, rack activated switch starts conveyor and pumps
- Automatic shut down stops operation during idle periods
- 2 HP wash motor recirculating 225 gpm
- Single point drain connection
- 2 large inspection doors
- Center-fed wash manifold
- Stainless steel front enclosure panel protects motors and controls from moisture
- Door safety switches prevents operation if door is open
- Stainless steel drain valves and poppets, foot activated
- Kit 55, included prv, shock arrestor and pressure gauge in final rinse line
- Bell-type stainless steel skimmer acts as overflow and removes fats and oils from the wash tank

### OPTIONS & ACCESSORIES

- Right to Left / Left to Right Operation
- Vent Cowls
- Rinse Booster Electric or Steam
- Circuit Breakers
- Optional Cabinet-Style Doors
- Table Limit Switch
- Correctional Package
- Voltage
  - 208V 220V 480V 60cy 3ph
- International options available, consult factory

# STERO ER-66S

## RACK CONVEYOR SERIES

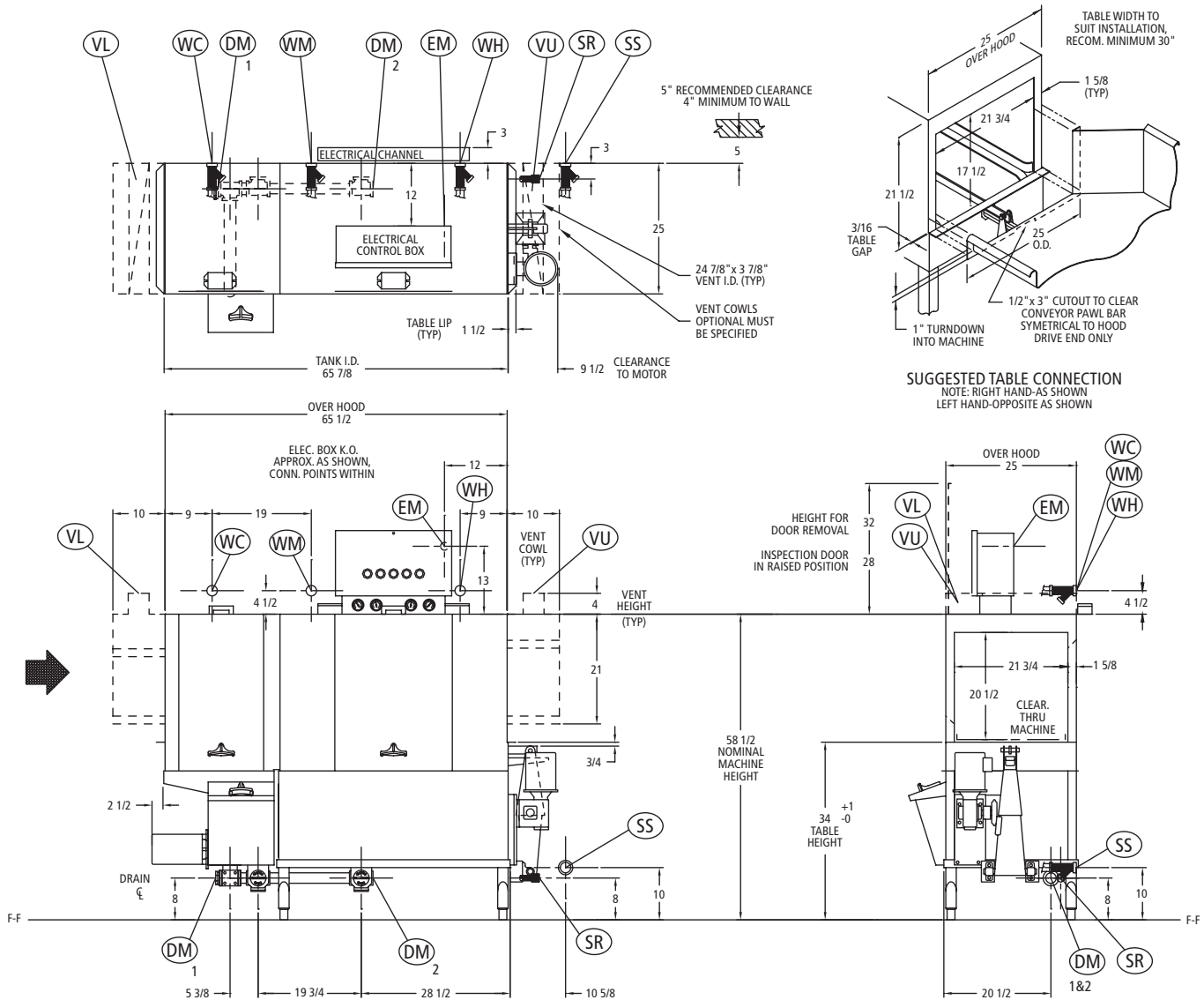

| ELECTRIC TANK HEAT |                  |   |
|--------------------|------------------|---|
| PTS.               | SIZE             | DESCRIPTION   |
| DM                 | 2" NPT (F) DRAIN | MACHINE WASTE: LEAVE UNUSED PORTS PLUGGED   |
| WC                 | 3/4" NPT (F)     | WATER SUPPLY: COLD AS AVAILABLE   |
| WM                 | 3/4" NPT (F)     | WATER SUPPLY: 140° MIN. TANK FILL   |
| WH                 | 3/4" NPT (F)     | WATER SUPPLY: 180°F. MIN. @ 20 PSI FLOW PRES. CONSUMPTION = 146 GALS./HR.   |
| EM                 | ELECTRICAL REQ.  | 1. SCRAPPER PUMP MOTOR ...1 HP<br>2. WASH PUMP MOTOR .....2 HP<br>3. CONVEYOR MOTOR.....1/4 HP<br>4. WASH TANK HEAT.....15 KW<br>TOTAL LOAD @ 208V-3 PH = 53.1 AMPS<br>TOTAL LOAD @ 480V-3 PH = 23.5 AMPS<br>SINGLE POINT CONNECTIONS REQUIRE MOUNTED CIRCUIT BREAKERS. MULTIPLE FEEDERS REQUIRED OTHERWISE |
| VL                 | NOTED            | VENT, LOAD END: RECOM. MIN. DRAW = 200 CFM  |
| VU                 | NOTED            | VENT, UNLOAD END: RECOM. MIN. DRAW = 400 CFM  |

NOTE: WC APPLIES ONLY IF COLD WATER AQUASTAT IS SPECIFIED

| STEAM TANK HEAT |                  |   |
|-----------------|------------------|---|
| PTS.            | SIZE             | DESCRIPTION   |
| DM              | 2" NPT (F) DRAIN | MACHINE WASTE: LEAVE UNUSED PORTS PLUGGED   |
| WC              | 3/4" NPT (F)     | WATER SUPPLY: COLD AS AVAILABLE   |
| WM              | 3/4" NPT (F)     | WATER SUPPLY: 140° MIN. TANK FILL   |
| WH              | 3/4" NPT (F)     | WATER SUPPLY: 180°F. MIN. @ 20 PSI FLOW PRES. CONSUMPTION = 146 GALS./HR.   |
| SS              | 1" NPT (F)       | STEAM SUPPLY: 15-40 PSI CONSUMPTION @ 20 PSI TANK HEAT: 100 LBS./HR.  |
| SR              | 3/4" NPT (F)     | STEAM RETURN:   |
| EM              | ELECTRICAL REQ.  | ONE (1) FEEDER SIZED FOR:<br>1. SCRAPPER PUMP MOTOR ...2 HP<br>2. WASH PUMP MOTOR .....2 HP<br>3. CONVEYOR MOTOR.....1/4 HP<br>TOTAL LOAD @ 208V-3 PH = 7.6 AMPS<br>TOTAL LOAD @ 480V-3 PH = 4.6 AMPS |
| VL              | NOTED            | VENT, LOAD END: RECOM. MIN. DRAW = 200 CFM  |
| VU              | NOTED            | VENT, UNLOAD END: RECOM. MIN. DRAW = 400 CFM  |

STANDARD 208V/230V/480V-3PH-60HZ AVAILABLE

### ER-66 L-R



# STERO ER-66S

## RACK CONVEYOR SERIES

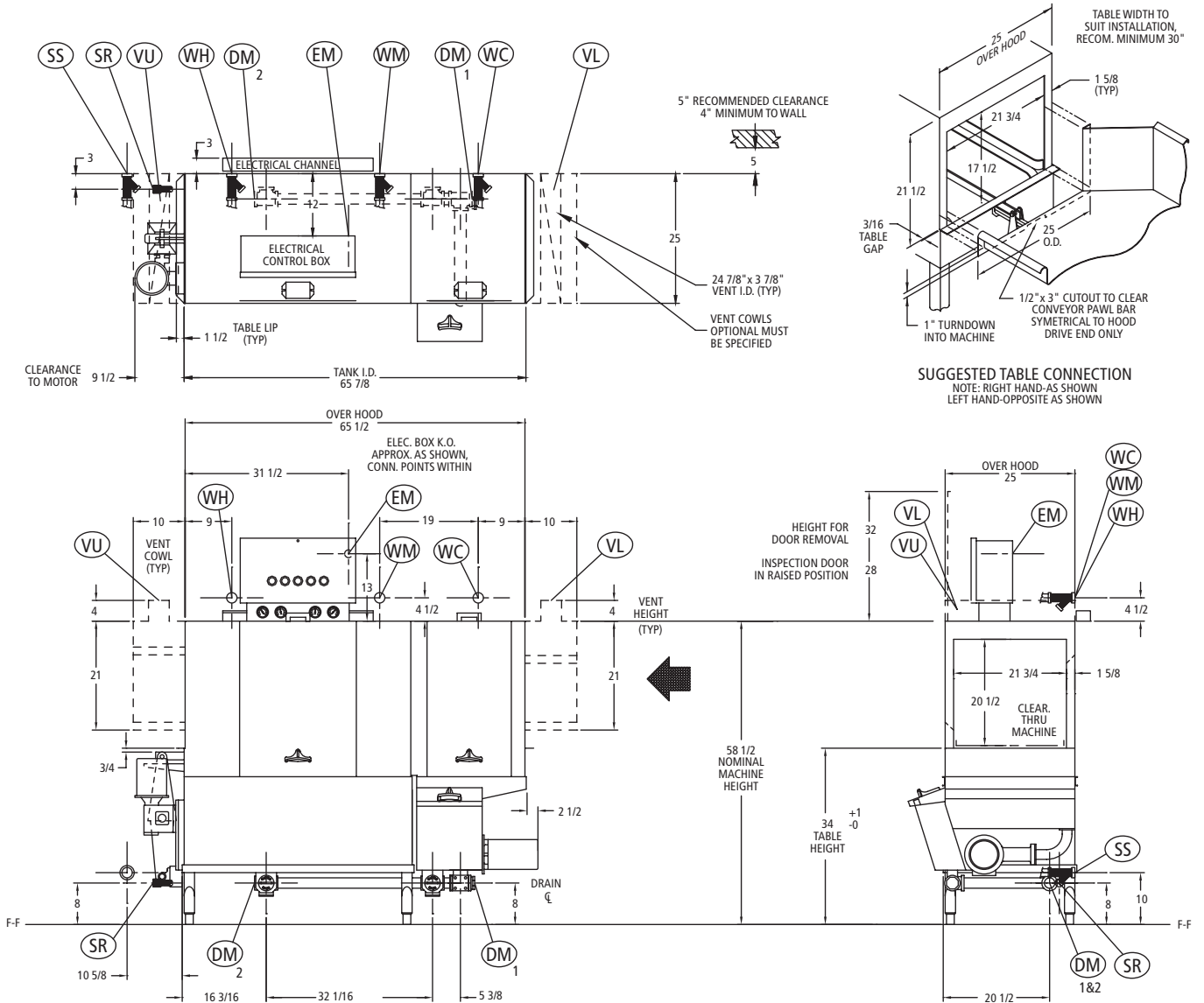

### ELECTRIC TANK HEAT

| PTS. | SIZE             | DESCRIPTION  |
|------|------------------|--|
| DM   | 2" NPT (F) DRAIN | MACHINE WASTE: LEAVE UNUSED PORTS PLUGGED  |
| WC   | 3/4" NPT (F)     | WATER SUPPLY: COLD AS AVAILABLE  |
| WM   | 3/4" NPT (F)     | WATER SUPPLY: 140° MIN. TANK FILL  |
| WH   | 3/4" NPT (F)     | WATER SUPPLY: 180°F. MIN. @ 20 PSI FLOW PRES. CONSUMPTION = 146 GALS./HR.  |
| EM   | ELECTRICAL REQ.  | 1. SCRAPER PUMP MOTOR ...1 HP<br>2. WASH PUMP MOTOR .....2 HP<br>3. CONVEYOR MOTOR.....1/4 HP<br>4. WASH TANK HEAT.....15 KW<br>TOTAL LOAD @ 208V-3 PH = 53.1 AMPS<br>TOTAL LOAD @ 480V-3 PH = 23.5 AMPS<br>SINGLE POINT CONNECTIONS REQUIRE MOUNTED CIRCUIT BREAKERS. MULTIPLE FEEDERS REQUIRED OTHERWISE |
| VL   | NOTED            | VENT, LOAD END: RECOM. MIN. DRAW = 200 CFM   |
| VU   | NOTED            | VENT, UNLOAD END: RECOM. MIN. DRAW = 400 CFM   |

NOTE: WC APPLIES ONLY IF COLD WATER AQUASTAT IS SPECIFIED

### STEAM TANK HEAT

| PTS. | SIZE             | DESCRIPTION  |
|------|------------------|--|
| DM   | 2" NPT (F) DRAIN | MACHINE WASTE: LEAVE UNUSED PORTS PLUGGED  |
| WC   | 3/4" NPT (F)     | WATER SUPPLY: COLD AS AVAILABLE  |
| WM   | 3/4" NPT (F)     | WATER SUPPLY: 140° MIN. TANK FILL  |
| WH   | 3/4" NPT (F)     | WATER SUPPLY: 180°F. MIN. @ 20 PSI FLOW PRES. CONSUMPTION = 146 GALS./HR.  |
| SS   | 1" NPT (F)       | STEAM SUPPLY: 15-40 PSI CONSUMPTION @ 20 PSI TANK HEAT: 100 LBS./HR.   |
| SR   | 3/4" NPT (F)     | STEAM RETURN:  |
| EM   | ELECTRICAL REQ.  | ONE (1) FEEDER SIZED FOR:<br>1. SCRAPER PUMP MOTOR ...2 HP<br>2. WASH PUMP MOTOR .....2 HP<br>3. CONVEYOR MOTOR.....1/4 HP<br>TOTAL LOAD @ 208V-3 PH = 7.6 AMPS<br>TOTAL LOAD @ 480V-3 PH = 4.6 AMPS |
| VL   | NOTED            | VENT, LOAD END: RECOM. MIN. DRAW = 200 CFM   |
| VU   | NOTED            | VENT, UNLOAD END: RECOM. MIN. DRAW = 400 CFM   |

STANDARD 208V/230V/480V-3PH-60HZ AVAILABLE

ER-66 R-L

# STERO ER-66S

## RACK CONVEYOR SERIES



**Design:** Two tank 20" Rack Conveyor, 66" in length with a power scrapper, power wash and a sanitizing fresh water final rinse. Flexible strip curtains at each end prevent splash out. Two large inspection doors allow easy access to interior of machine for cleaning and maintenance.

**Construction:** Tank and hood are formed from 300 series No. 4 mill finish stainless steel, fully welded with a minimum of bolt together construction. Frame is heavy-duty stainless steel flat stock construction conforming to National Sanitation Foundation (NSF) Standard No. 3. The machine is supported by enclosed stainless steel feet. All internal piping, fittings, risers and manifolds are stainless steel.

**Power Scrapper:** The STERO engineered scrapping pattern utilizes fixed upper and lower stainless manifolds, fitted with large stricture free jets which effectively strip the food soil from all types of ware as it passes through the spray pattern. The food soil drops onto flat perforated stainless steel screens that cover the tank. The screens are held in an inclined position which coupled with the pump action, automatically moves the food soil to a scrap catchment mounted outside the tank.

**Power Wash:** STERO's unique stainless steel manifolds are center-fed, fitted with stricture free jets with directional vanes and can be easily removed without tools. Center fed manifolds distribute an even flow of wash water over the entire perimeter of the rack, ensuring consistent results. The ER-66S distributes 225 GPM of detergent water pumped over the ware by a 2 HP motor and pump assembly.

**Final Rinse:** Stainless rinse arms mounted above and below are fitted with directional fanjets, which create a full coverage spray pattern for maximum rinsing and sanitation. The rack activates STERO's final rinse switch and hot water solenoid valve with stainless steel seat. A vacuum breaker mounted downstream from the solenoid and 6" above the upper rinse complete STERO's rinse system.

**Conveyor:** A center-drive stainless steel pawl bar with stainless steel pawls conveys the racks through the spray pattern and out onto the clean dish table. The conveyor is powered by an integral ¼ HP motor and speed reducing drive which has a built-in release to prevent damage to racks or machine in the event of a rack jam. The racks ride on 12 gauge stainless steel tracks.

**Standard Electrical Features:** All motors on STERO conveyor machines are factory wired in waterproof conduit and fittings to a common connection point. The motors are protected by thermal-overloads with manual reset buttons. The magnetic motor starters, start-stop switches, and electric tank heating element contactors (when specified) are mounted in a stainless steel control box for one point connection.

**Door Safety Switch:** Prevents the machine from operating if the door is open. The machine will automatically shut-off if the door is opened while the washer is running.

**Thermometers:** One each for the scrap, wash, and final rinse.

**Pumps & Motors:** 2 HP, 1750 rpm, 225 GPM, heavy duty with sealed bearings and overload protection. The pumps have easily removable inspection plates—front and end—and are self draining. Stainless steel perforated strainer pans cover the tank.

### TANK HEATING OPTIONS

**Electric:** Stainless steel elements totaling 15 kW are mounted in the bottom of the wash tank. The unit is thermostatically controlled and has STERO's low water protection system. The elements, thermostat, LWP and contactor are all inter-wired to the control panel.

**Steam Injectors:** Two stainless steel injectors with silencers are mounted in the tank. A thermostat controls a special solenoid valve, and maintains the correct temperature.

**Steam Coils:** STERO designed and built stainless steel steam coils are mounted in the tank. Steam coils allow condensed steam to be returned to the steam generator, a decided advantage when there is a question of steam purity. A thermostat controls a special steam solenoid valve and maintains the correct temperature. A steam trap is mounted on the steam return line.

*In line with its policy to continually improve its products, Stero reserves the right to change materials and specifications without notice.*