

# THE STERO COMPANY SCT/SC CONVEYOR EARLY ER SERIES TYPE DISHWASHERS

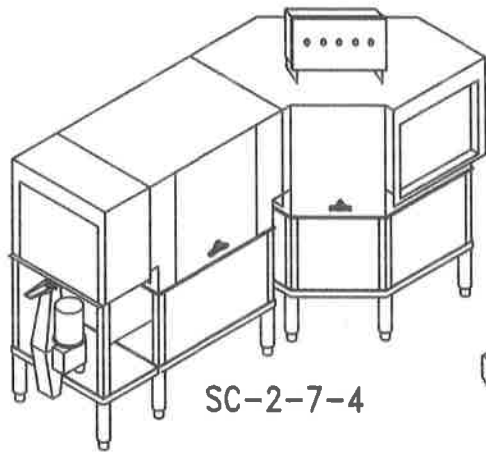

SC-2-7-4

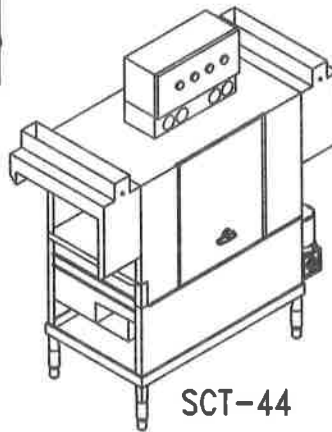

SCT-44

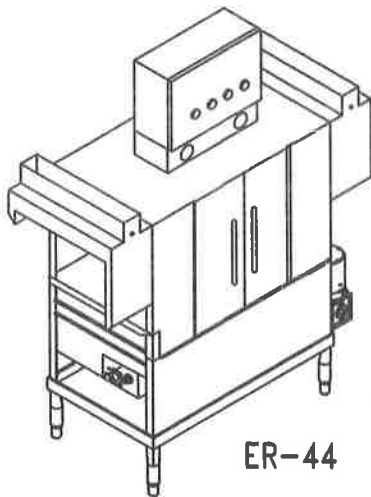

ER-44



MODEL# \_\_\_\_\_  
SERIAL# \_\_\_\_\_

THE STERO COMPANY  
1758 CORPORATE CIRCLE  
PETALUMA, CA. 94954  
(707) 762-0071  
(800) 762-7600  
FAX# (707) 762-1954  
ERP-GEN101 04/2020





# FRAMES

TYPICAL SCT

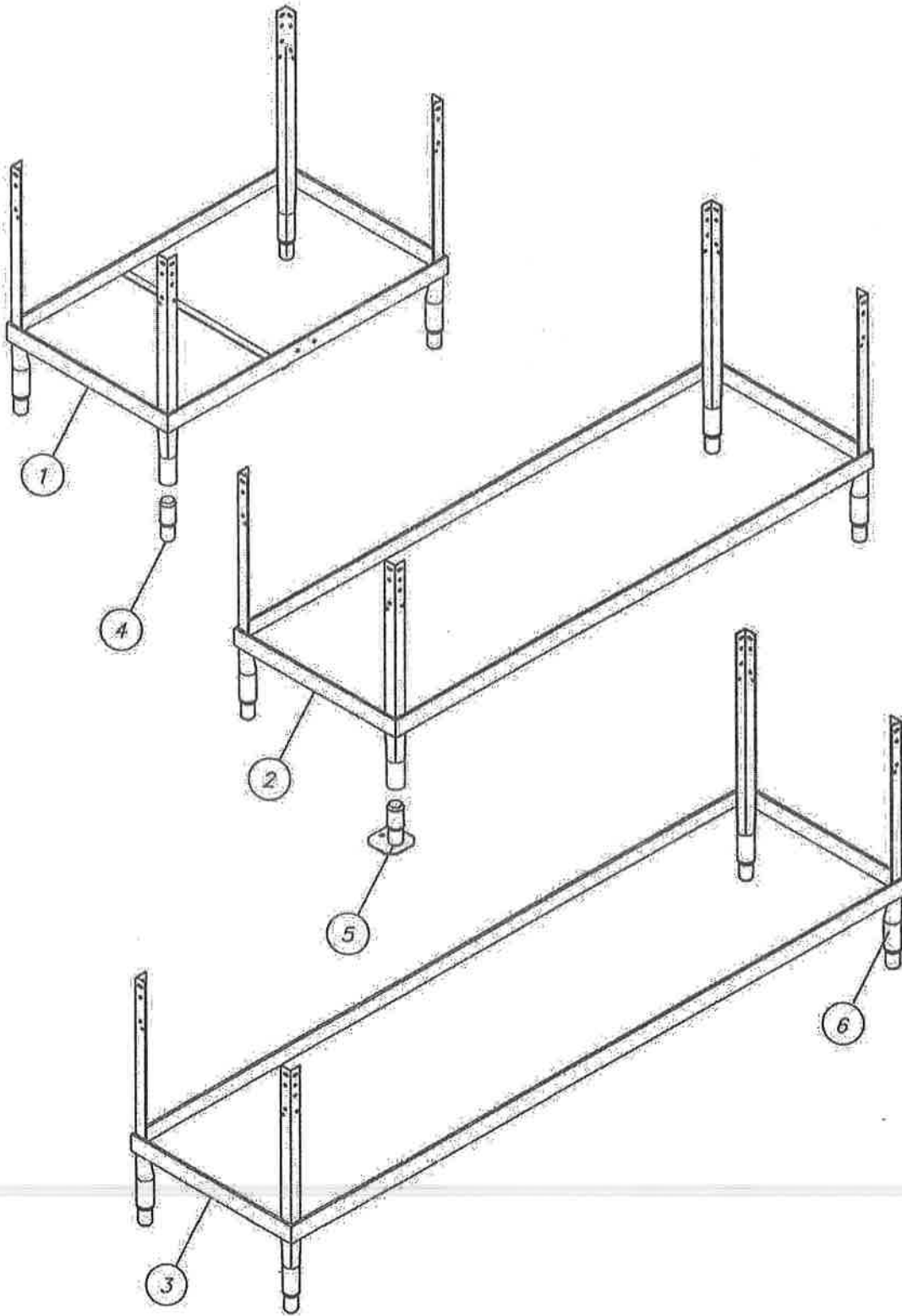

(01)



# FRAMES

TYPICAL SC

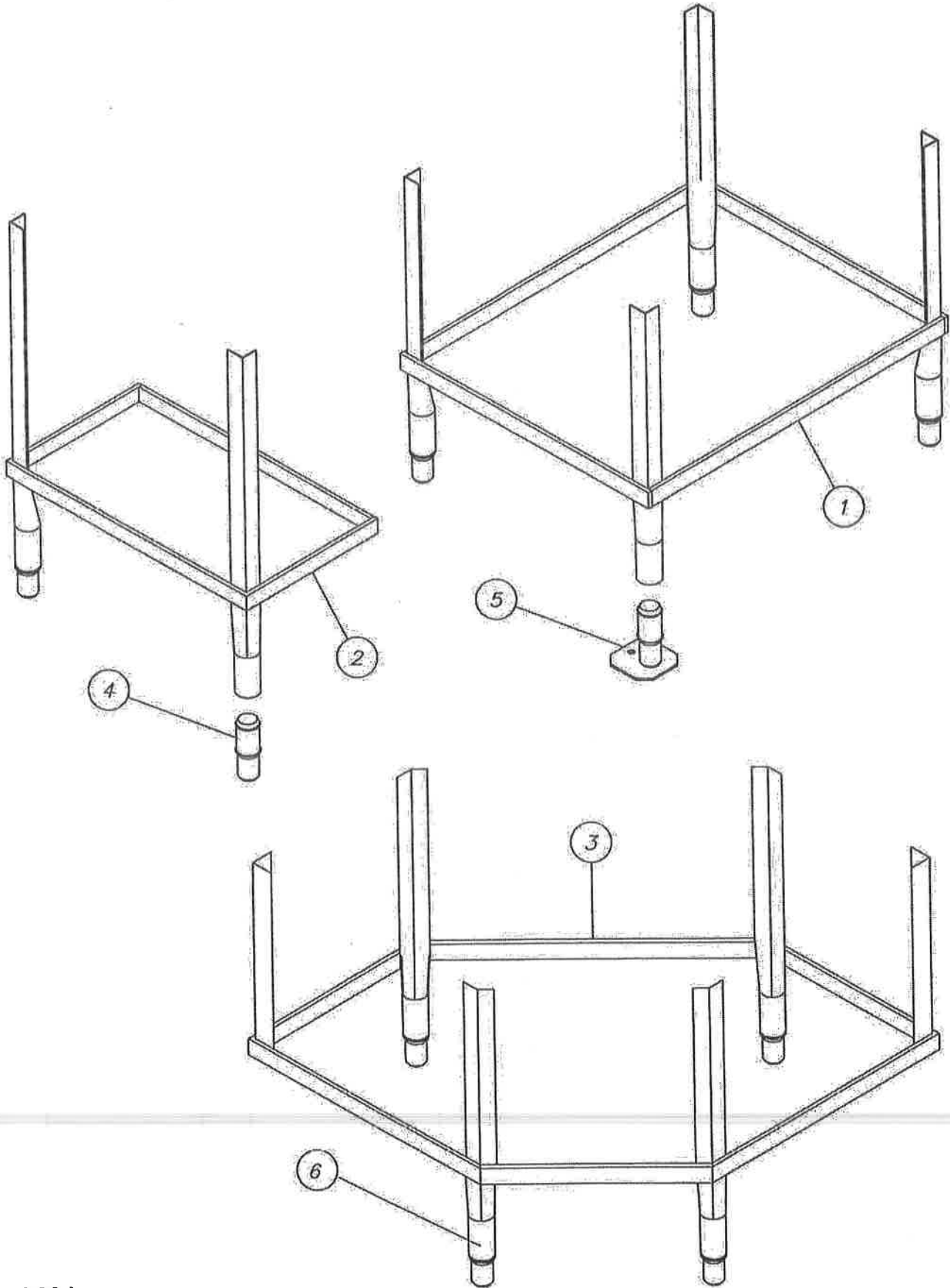

(03)



# FRONT PANELS

TYPICAL SCT

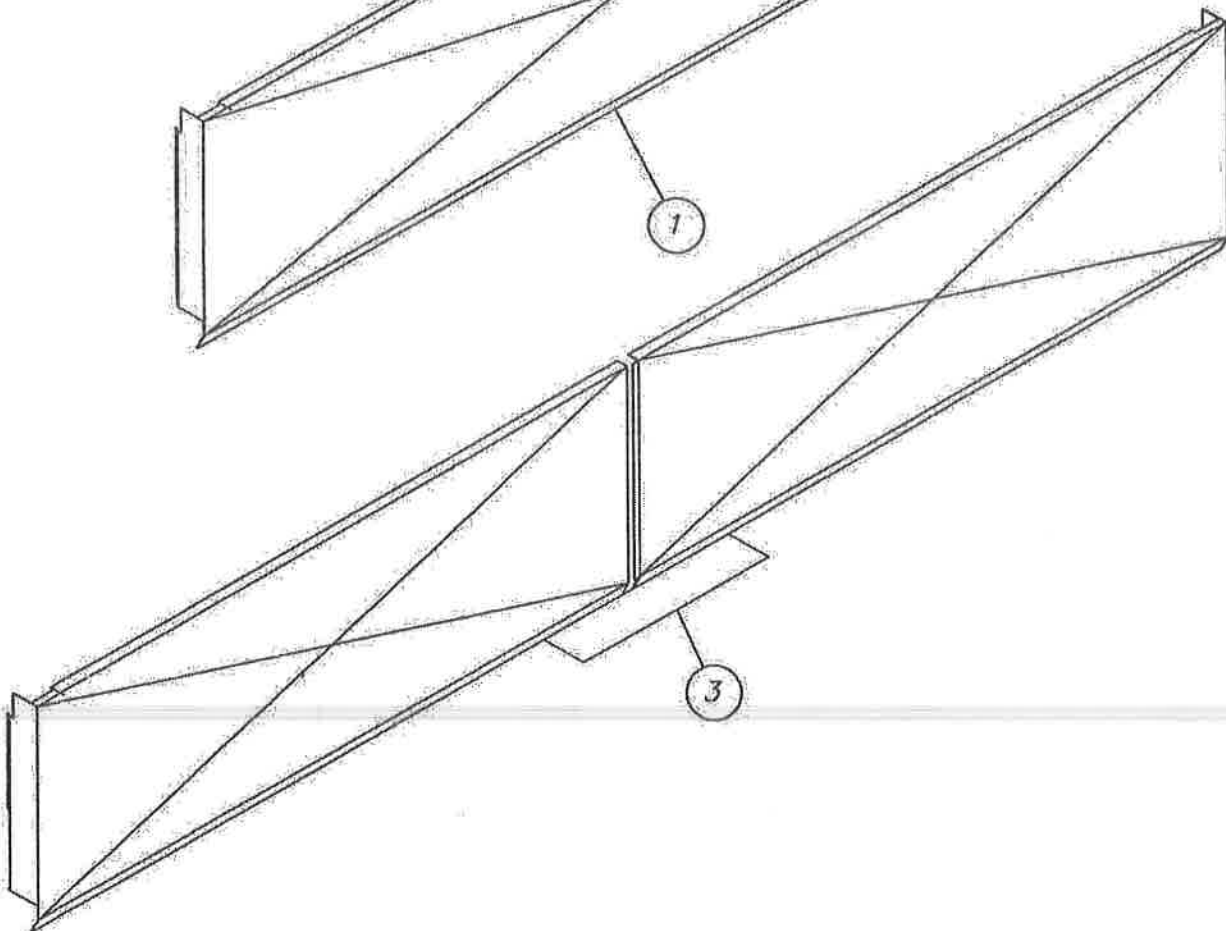
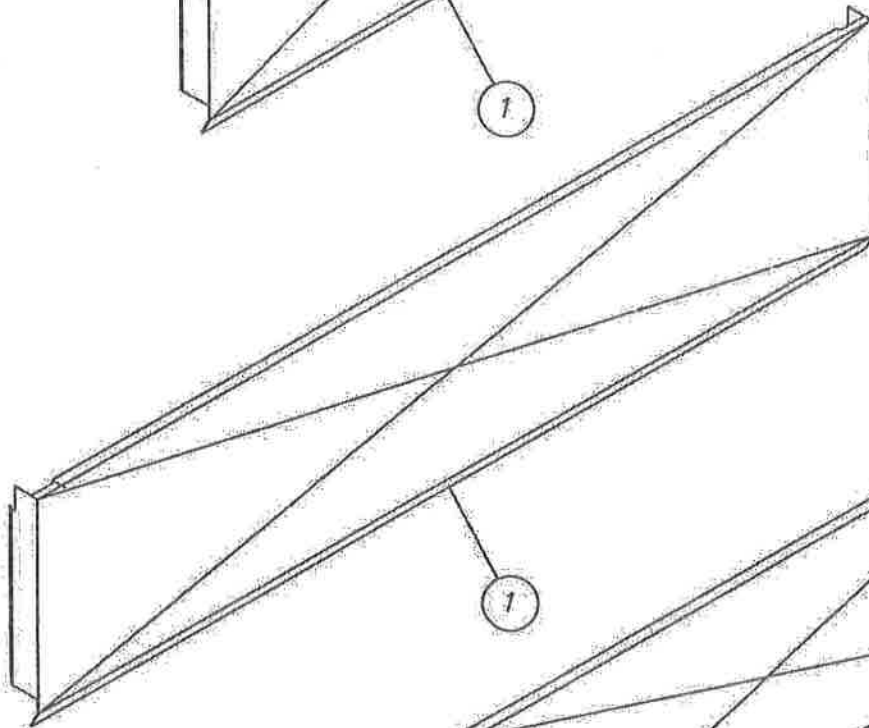
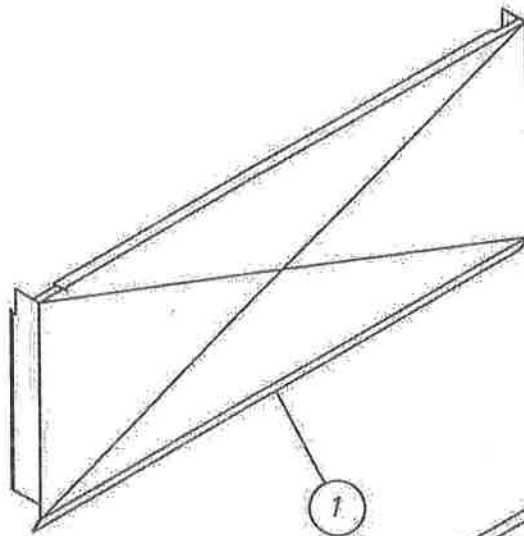

(05)





# FRONT MOTOR PANELS

TYPICAL SC

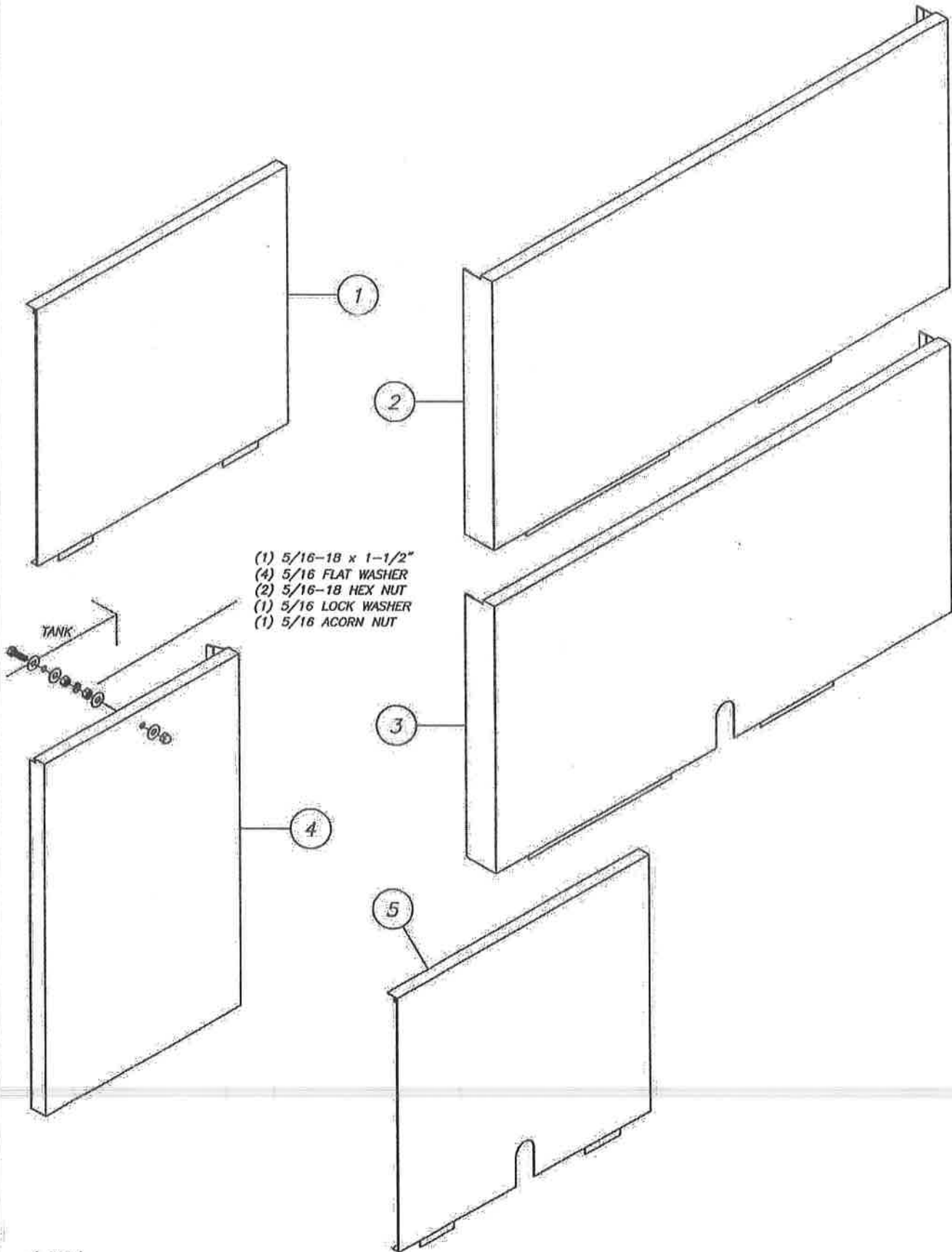

(07)



# TYPICAL SCT TANKS

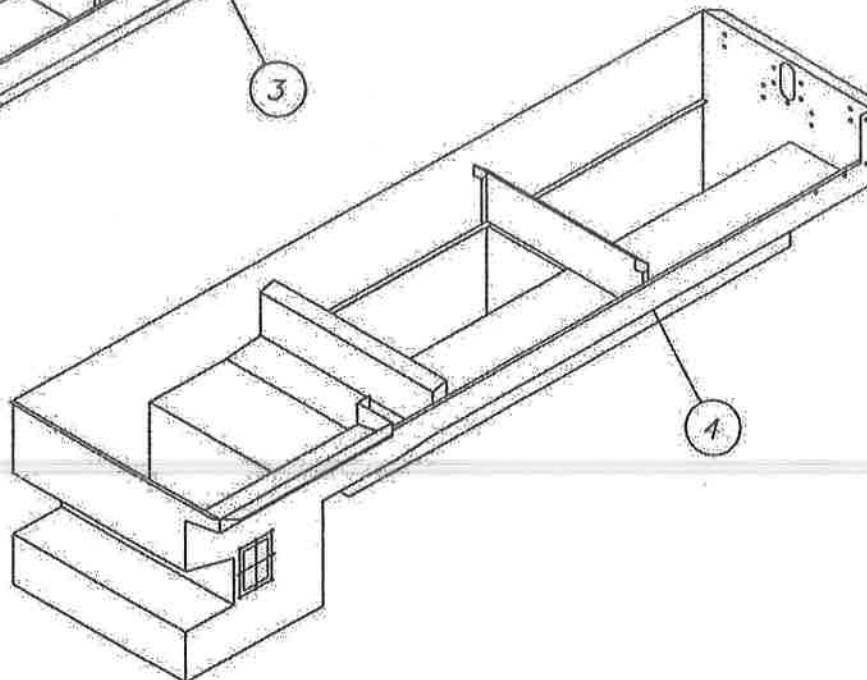
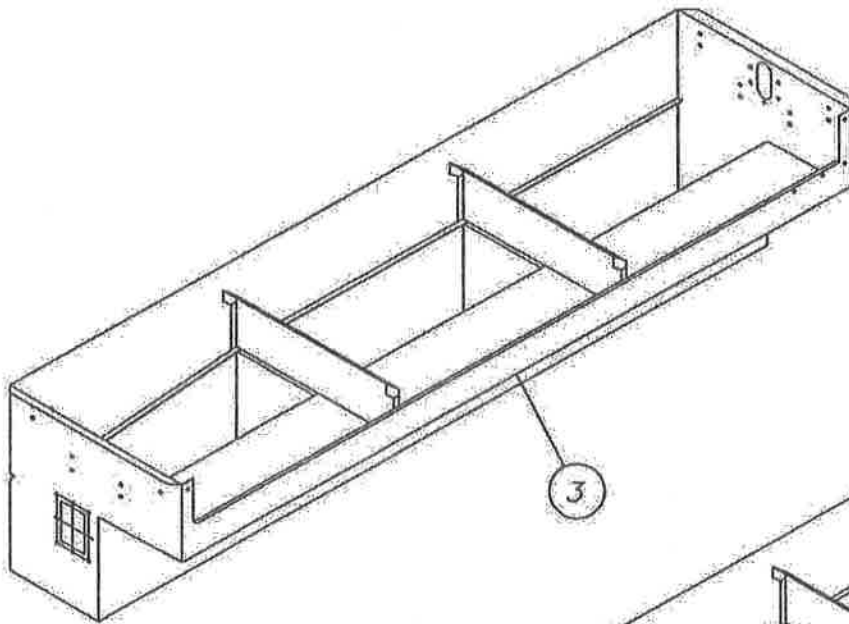
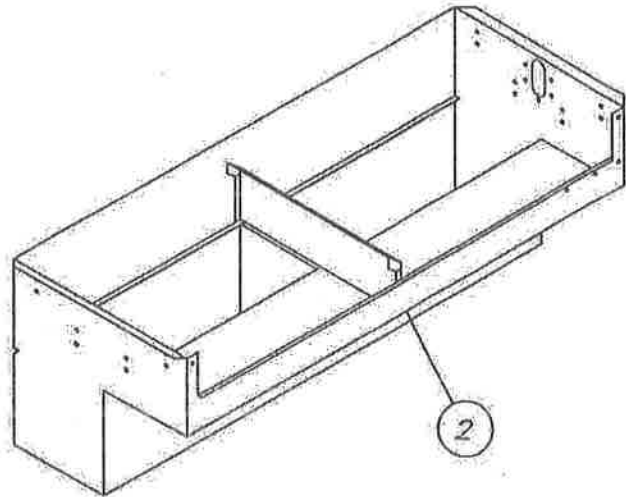
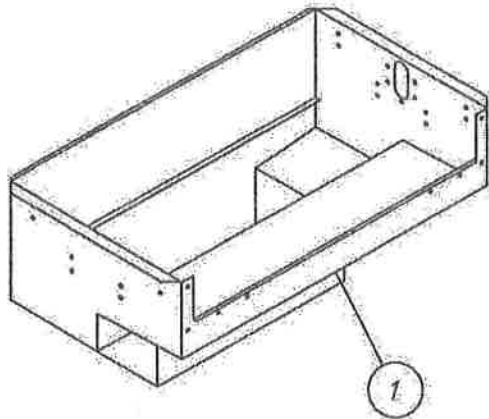

# TYPICAL SCT TANKS

ITEM	DESCRIPTION	REMARKS	REQ.	PART NO.
1	SINGLE TANK			*
1	SINGLE TANK	SCT-66S, SC		B10-2283
2	DOUBLE TANK			*
3	TRIPLE TANK			*
4	DOUBLE TANK WITH CORNER LOAD	SCRAPPER		*

# TYPICAL SC TANKS

TYPICAL SCT

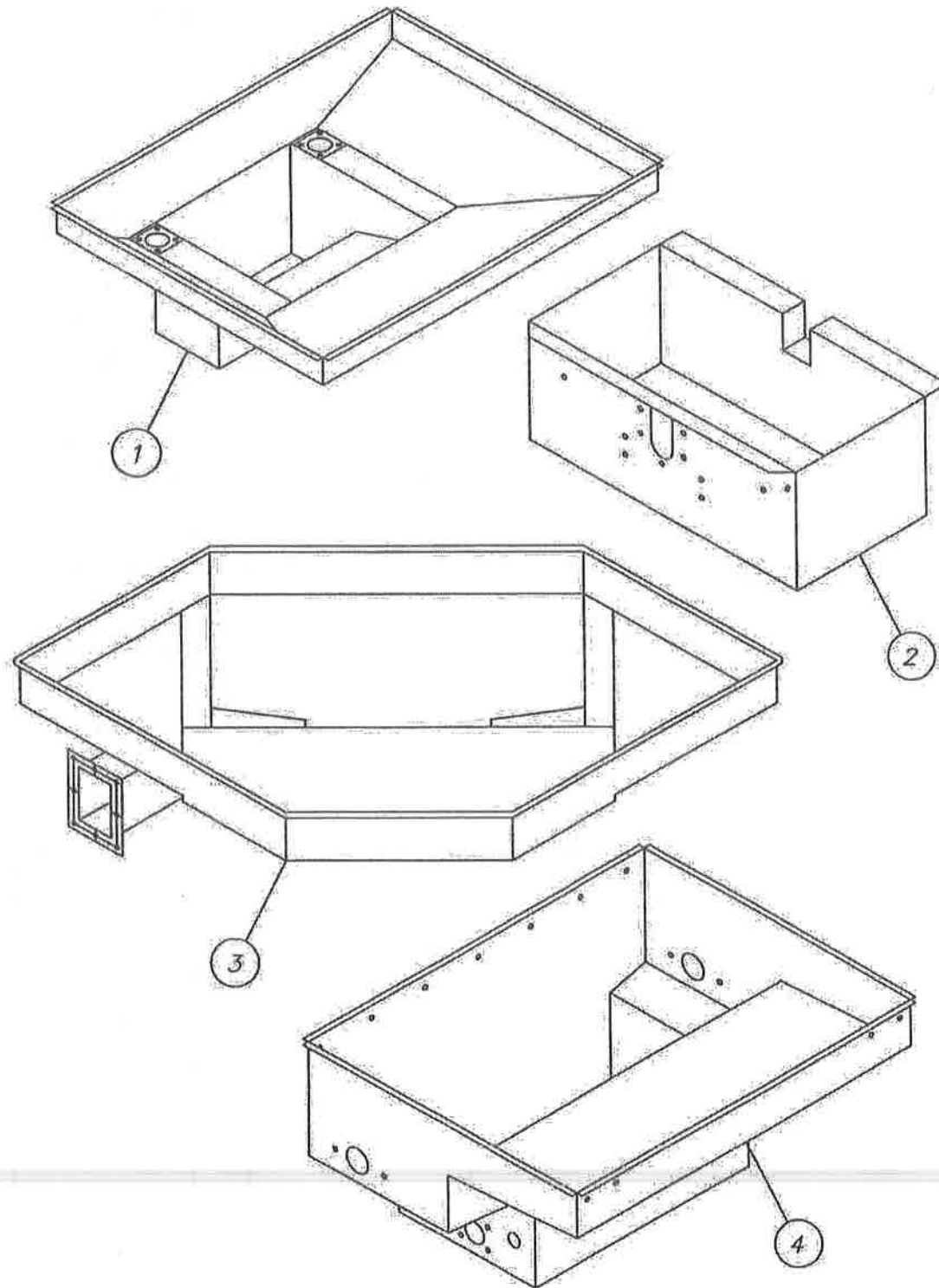



# SCRAP CATCHMENT & BASKETS

TYPICAL SCT

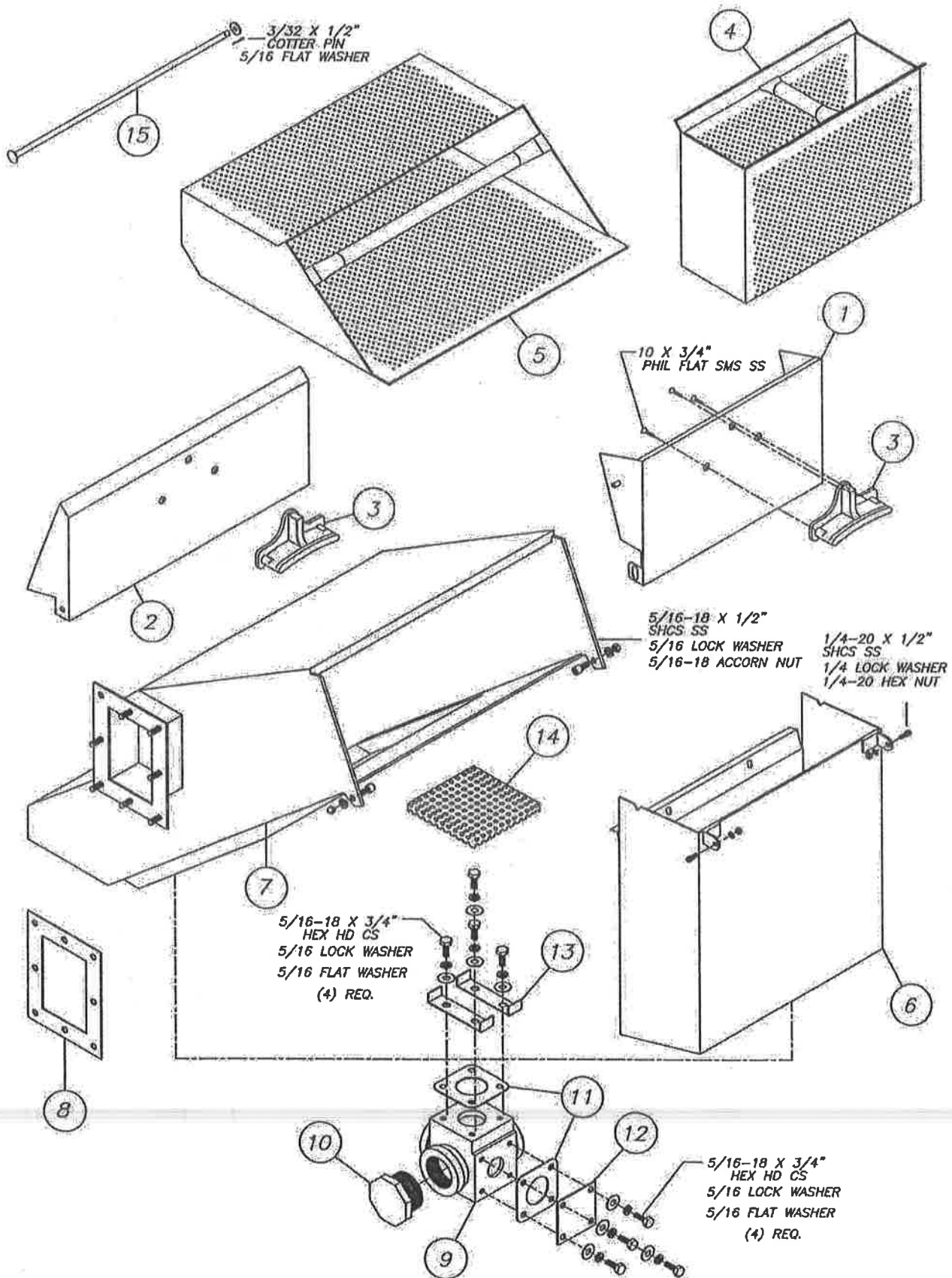





# STRAINER PANS

SCT / SC

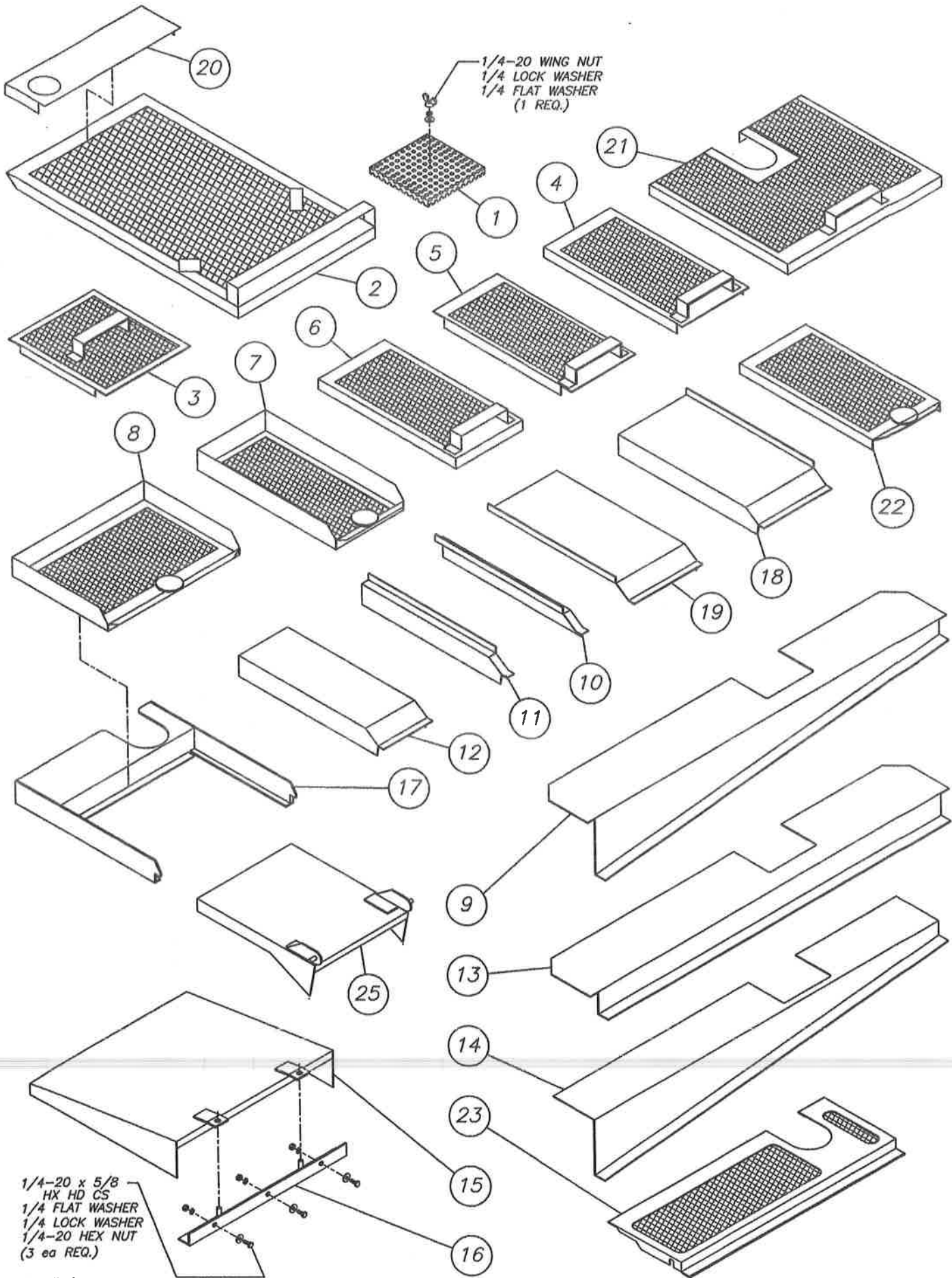

## STRAINER PANS

SCT / SC

ITEM	DESCRIPTION	REMARKS	REQ.	PART NO.
1	SCREEN, DRAIN - 5-1/4 x 5-1/4"		1	A10-2616
2	STRAINER PAN, SCRAP SCREEN - 12-1/2 x 21"	SCT-66S-CS	1	B10-2261
	STRAINER PAN, SCRAP SCREEN - 16-1/2 x 21"		1	B10-6030
3	STRAINER PAN, OPEN ENDS W / HANDLE -			
	- 8-3/4 x 7-3/4"		1	A10-2718
4	STRAINER PAN, SCRAPER - 6-1/4 x 12-1/2"	SC-1	1	A10-3611
5	STRAINER PAN, SCRAP OPEN ENDS W /HANDLE			
	- 12-1/2 x 5-7/8"	SC-1	1	A10-2717
6	STRAINER PAN, - 12-1/2 x 6-1/4"	SCT-76S-CS	1	A10-2716
7	STRAINER PAN, SCR CATCHMENT -12-1/2 x 6-1/4"		1	A10-2088
8	STRAINER PAN, SCRAP-CENTER -12-1/2 x 8-1/2"		1	A10-2090
9	DEFLECTOR, REAR STRAINER PAN - LR	SC-1 (SHOWN)	1	B10-3659
	DEFLECTOR, REAR STRAINER PAN - RL	SC-1	1	B10-3660
10	SPACER, STRAINER PAN - LEFT - 3/4"		1	*A10-5166
11	SPACER, STRAINER PAN - RIGHT - 3/4"		1	*A10-5166
12	SPACER, STRAINER PAN - CENTER - 4"		1	*
	L-R	SCT-44	1	A10-6026
	R-L	SCT-44	1	A10-6027
13	DEFLECTOR, REAR STRAINER PAN -	SC-2-3	1	B10-3606
14	DEFLECTOR, REAR STRAINER PAN - LR	SC-5 (SHOWN)	1	B10-3629
	DEFLECTOR, REAR STRAINER PAN - RL	SC-5	1	B10-3628
15	DIVERTER, SCRAP TANK WATER	SCT-76S	1	B10-3797
16	BRACKET, SCRAP TANK WATER DIVERTER	SCT-76S		A10-3798
17	BRACKET, CENTER WASH CATCHMENT SUPPORT		1	*A10-2083
18	SPACER, STRAINER PAN - RIGHT - 6"		1	A10-2027
19	SPACER, STRAINER PAN - LEFT - 6"		1	A10-2026
20	BAFFLE, SCRAP RISER TUBE 12-1/2" - LR	SCT-66S-CS (SHOWN)	1	*B10-2271
	BAFFLE, SCRAP RISER TUBE 12-1/2" - RL	SCT-66S-CS	1	*B10-2271
	BAFFLE, SCRAP RISER TUBE 16-1/2" - LR	SCT-76S	1	*B10-2271
	BAFFLE, SCRAP RISER TUBE 16-1/2" - RL	SCT-76S	1	B10-2271
21	STRAINER PAN, 12-1/2 X 14"	SCT-76S-94S-120S	1	A10-4118
22	STRAINER PAN, ER WASH TANK 13-1/4 X 13-5/8" ER		3	A10-6647
23	SUPPORT, REAR STRAINER PAN LR / RL	ER	1	A10-6737
24	STRAINER PAN AUX. RINSE TANK 12 X 5-3/4"	ER	1	A10-6375
25	WATER DIVERTER SCRAP TANK SC-5 8-9/16" X 10-5/8"		1	A10-2701A

\* TO ORDER SUPPLY MACHINE MODEL AND SERIAL NUMBER

( 16 )

# TYPICAL SCT HOODS

TYPICAL SCT

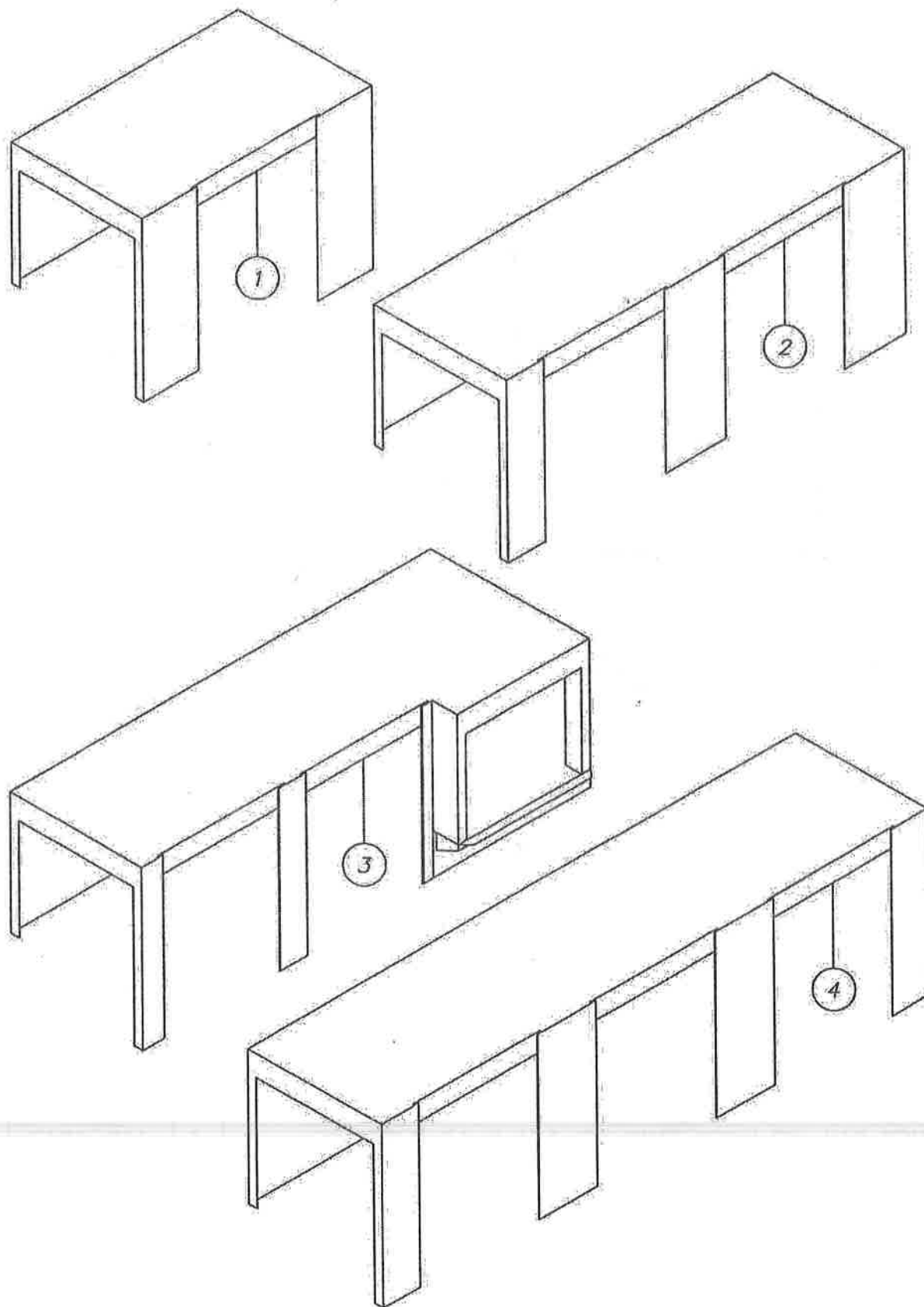



# SC HOODS

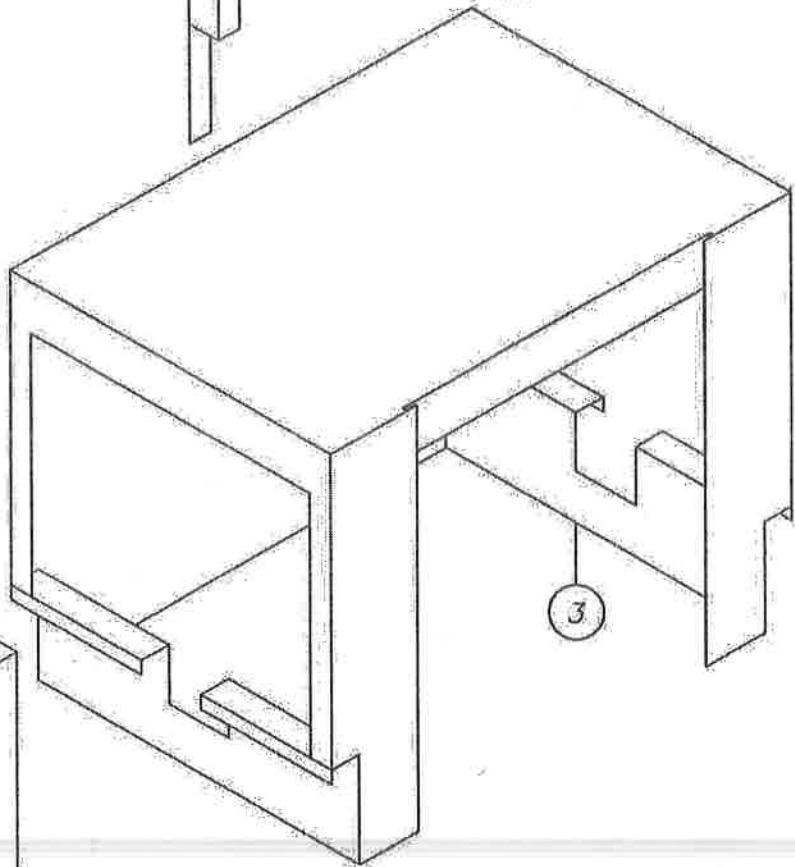
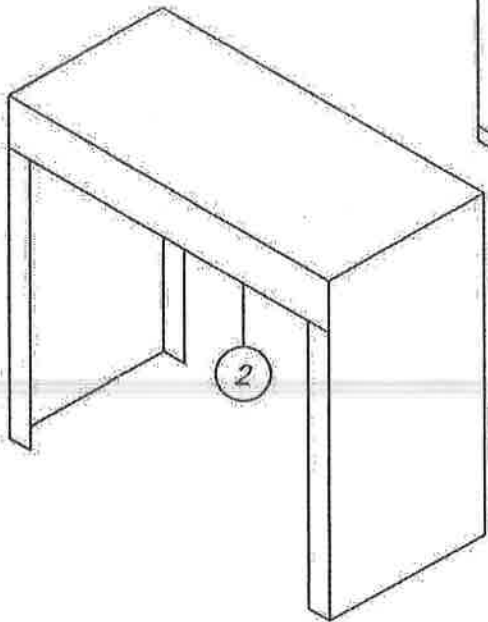
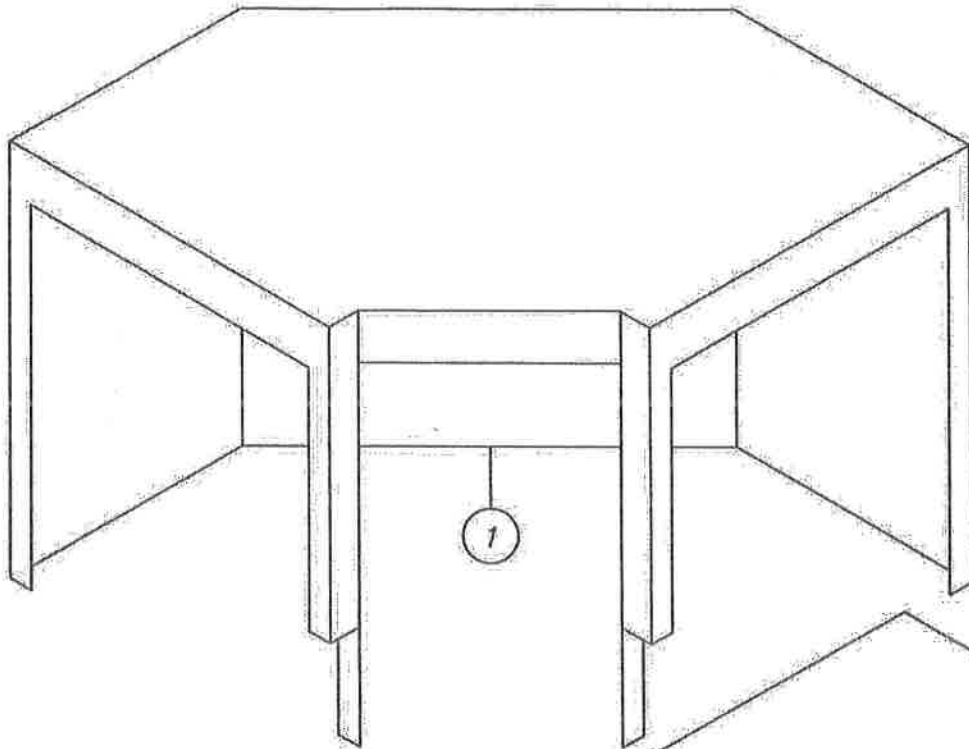

# SC HOODS

ITEM	DESCRIPTION	REMARKS	REQ.	PART NO.
1	90° HOOD			*
2	36" STRAIGHT THRU HOOD			*
3	SC-4 TYPE HOOD			*

\* TO ORDER SUPPLY MACHINE MODEL AND SERIAL NUMBER ( 20 )

# LIFT-OUT DOORS

MOUNTING HARDWARE  
 4-40 X 3/8" TRUSS HD  
 4-40 NYLOCK NUT

SCT-66S SCRAPPER DOOR AND  
 SC-1-2-3-9 DOOR

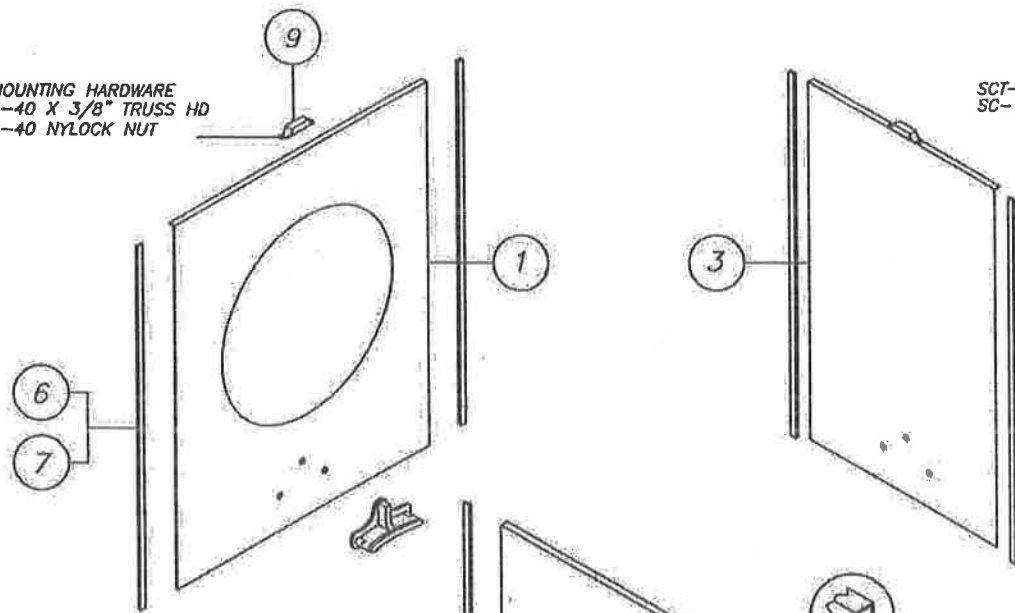

10 X 3/4"  
 PHIL FLAT SMS SS

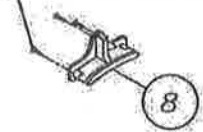

NOTE:  
 WHEN ORDERING DOORS FOR  
 ER MACHINES ALWAYS PUT ER  
 AFTER PART NUMBER.

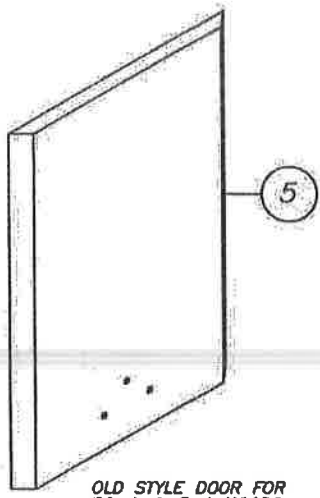
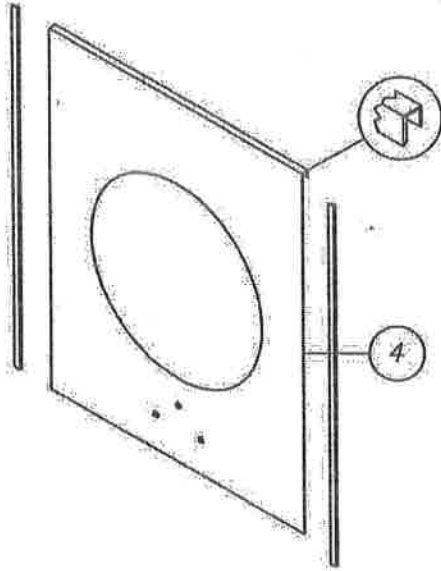
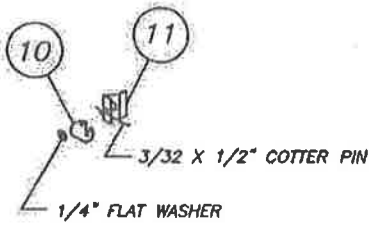

OLD STYLE DOOR FOR  
 SC-1-2-3-9 HOODS

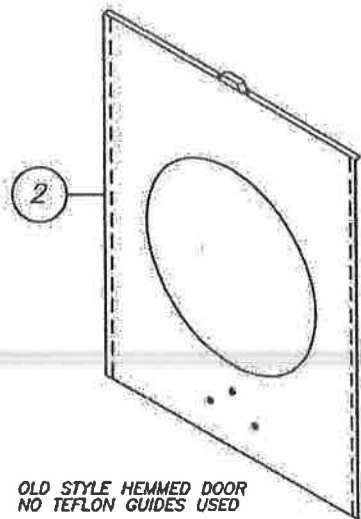

OLD STYLE HEMMED DOOR  
 NO TEFLON GUIDES USED



# LIFT-OUT DOORS

ITEM	DESCRIPTION	REMARKS	REQ.	PART NO.
	ALWAYS SUPPLY MODEL AND SERIAL NUMBER WHEN ORDERING DOORS, ALSO			
	MEASURE DOORS WHEN POSSIBLE TO INSURE CORRECT FIT.			
	STANDARD CONVEYOR DOOR FOR MODELS SCT & SC SECTIONS 5,6,7,8 WITH			
	TEFLON STYLE DOORS AFTER 10-99			
1	STANDARD DOOR (SCT-44)	23-5/8" X 29"		A10-5844
	STANDARD DOOR PLUS 3"	23-5/8" X 32"		A10-5978
	STANDARD DOOR PLUS 6"	23-5/8" X 35"		A10-5979
	BLANK STANDARD DOOR (ET-44)	23-5/8" X 29"		A10-5977
2	HEMMED DOORS USED ON MACHINES UNTIL 1995			
	STANDARD DOOR (SCT-44)	23-5/8" X 29"		A10-2016
	STANDARD DOOR PLUS 3"	23-5/8" X 32"		A10-5847
	STANDARD DOOR PLUS 6"	23-5/8" X 35"		A10-5845
3	22" SCRAPPER AND MODULAR SC SECTIONS 1,2,3,9			
	TEFLON STYLE DOORS USED AFTER 10-99			
	DOOR FOR SC-1-2-3-9 SECTION STANDARD	17-1/2" X 29"		A10-5846
	DOOR FOR SC-1-2-3-9 SECTION PLUS 3"	17-1/2" X 32"		A10-5982
	DOOR FOR SC-1-2-3-9 SECTION PLUS 6"	17-1/2" X 35"		A10-5983
	HEMMED STYLED DOOR USED BEFORE 10-99			
	DOOR FOR SC-1-2-3-9 SECTION STANDARD	17-1/2" X 29"		A10-3569
	DOOR FOR SC-1-2-3-9 SECTION PLUS 3"	17-1/2" X 32"		A10-5980
	DOOR FOR SC-1-2-3-9 SECTION PLUS 6"	17-1/2" X 35"		A10-5981
4	ER MACHINE TEFLON STYLE DOORS			
	ER-44 DOOR STANDARD	23-5/8" X 28.5"		A10-5844ER
	ER-44 DOOR + 3"	23-5/8" X 31.5"		A10-5978ER
	ER-44 DOOR + 6"	23-5/8" X 34.5"		A10-5979ER
	ER 22" SCRAP. TEFLON STYLE DOORS	NOT SHOWN		
	ER 22" SCRAPPER DOOR STANDARD	17-1/2" X 28.5"		A10-3569ER
	ER 22" SCRAPPER DOOR + 3"	17-1/2" X 31.5"		A10-5980ER
	ER 22" SCRAPPER DOOR + 6"	17-1/2" X 34.5"		A10-5981ER
	HEMMED STYLE DOORS FOR SCT-76SC			
	STANDARD DOOR FOR SCT-76SC	21-5/8" X 29"		A10-3666
	STANDARD DOOR FOR SCT-76SC PLUS 3"	21-5/8" X 32"		*
	STANDARD DOOR FOR SCT-76SC PLUS 6"	21-5/8" X 35"		*
5	OLD STYLE 45 DOORS USED BEFORE 10-99			
	DOORS FOR SC-1-2-3-9 SECTION	17-1/2" X 29"		A10-3608
	DOORS FOR SC-1-2-3-9 SECTION	17-1/2" X 32"		A10-5984
	DOORS FOR SC-1-2-3-9 SECTION	17-1/2" X 35"		A10-5985
6	BLUE DOOR TEFLON GUIDE	28-1/4"		P57-5775
7	BLUE DOOR TEFLON GUIDE EXTENDED DOORS	31-1/2"		P57-6948
7	BLUE DOOR TEFLON GUIDE EXTENDED DOORS	36-1/2"		P57-5286
8	BLUE PLASTIC DOOR HANDLE W/SCREWS			B59-1448
9	DOOR MAGNET FOR REED SWITCH			A10-4275
10	CATCH SAFETY			A10-1578
11	BRACKET DOOR SAFETY CATCH			A10-1759

\* TO ORDER SUPPLY MACHINE MODEL AND SERIAL NUMBER

# SCT & ER CABINET STYLE DOORS

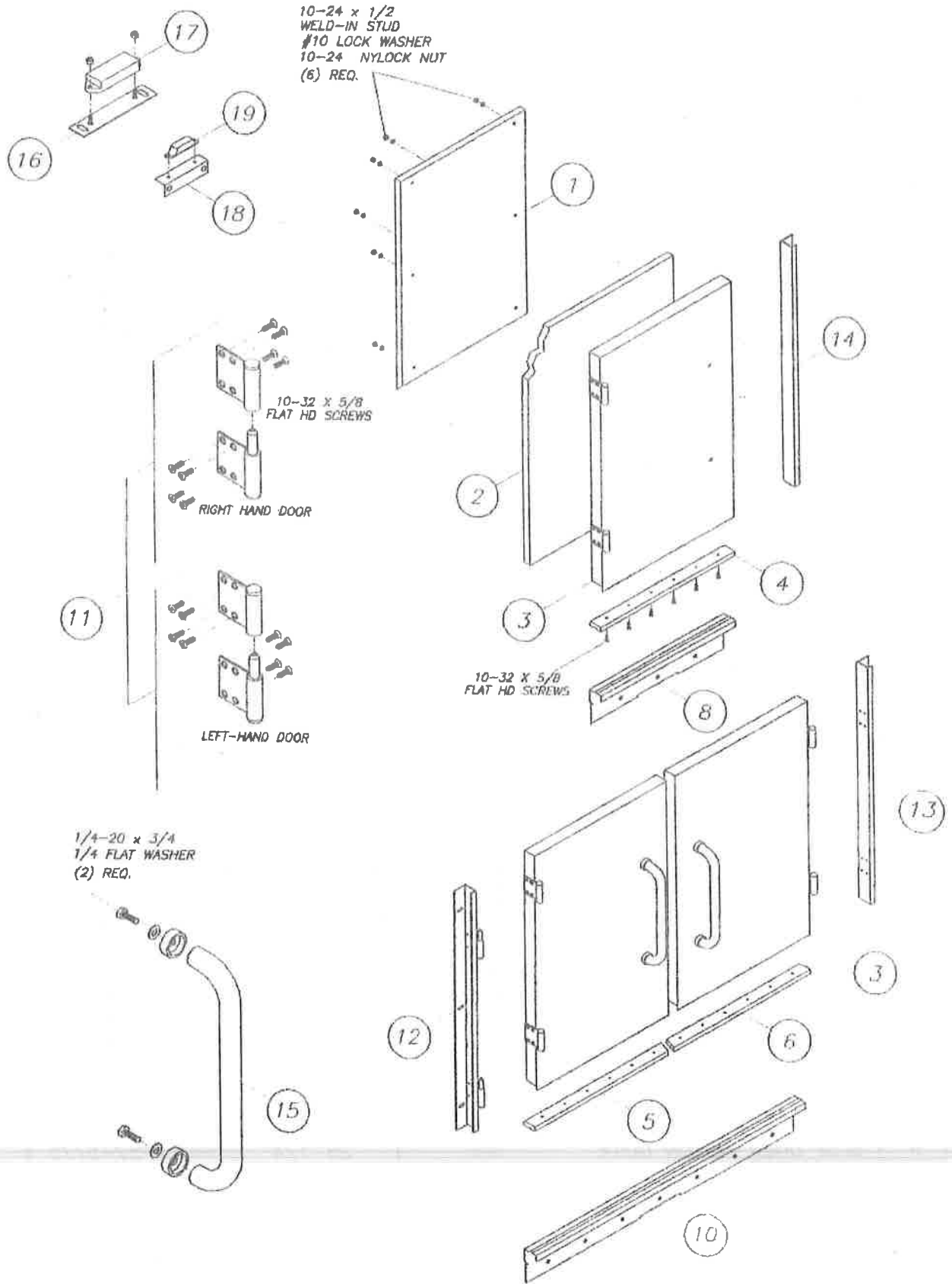

## SCT & ER CABINET STYLE DOORS

ITEM	DESCRIPTION	REMARKS	REQ.	PART NO.
1	INNER DOOR SKIN STD. 18"			*
	INNER DOOR SKIN STD. 24"			*
	INNER DOOR SKIN DOUBLE DOORS 36" LEFT			*
	INNER DOOR SKIN DOUBLE DOORS 36" RIGHT			*
2	DOOR INSULATION 3/4" NEOPRENE			A10-1407
3	OUTER DOOR SKIN STD. 18"			Z99-0035
	OUTER DOOR SKIN STD. 24"			Z99-0036
	OUTER DOOR SKIN 36" SET			Z99-0037
4	SEAL DOOR 18" UHMW NARROW	ER-64		A10-6690
5	SEAL 2 DR LEFT UHMW NARROW	SCT-44		A10-6691
6	SEAL 2 DR RIGHT UHMW NARROW	SCT-44		A10-6692
7	SEAL DOOR 24" UHMW WIDE			A10-6693
8	THRESHOLD 18" SCT NARROW DOOR			A10-6723
9	THRESHOLD 24" SCT WIDE DOOR			A10-6724
10	THRESHOLD 36" SCT DOUBLE DOOR			A10-6725
11	HINGE INSULATED DOOR RIGHT			P60-6680R
	HINGE INSULATED DOOR LEFT			P60-6680L
12	DOOR HINGE MOUNTING BRACKET LEFT-SIDE			*
13	DOOR HINGE MOUNTING BRACKET RIGHT-SIDE			*
14	DOOR HINGE MOUNTING BRACKET BLANK			*
15	HANDLE TUBULAR INSULATED DOOR			A10-6703
16	BRACKET INSULATED DOOR SWITCH			A10-6735
17	REED SWITCH ASSEMBLY			B10-4274
18	BRACKET INSULATED DOOR MAGNET			A10-6736
19	MAGNET ASSY STERO REED B10-4274			A10-4275

\* TO ORDER SUPPLY MACHINE MODEL AND SERIAL NUMBER

# EXHAUST VENTS

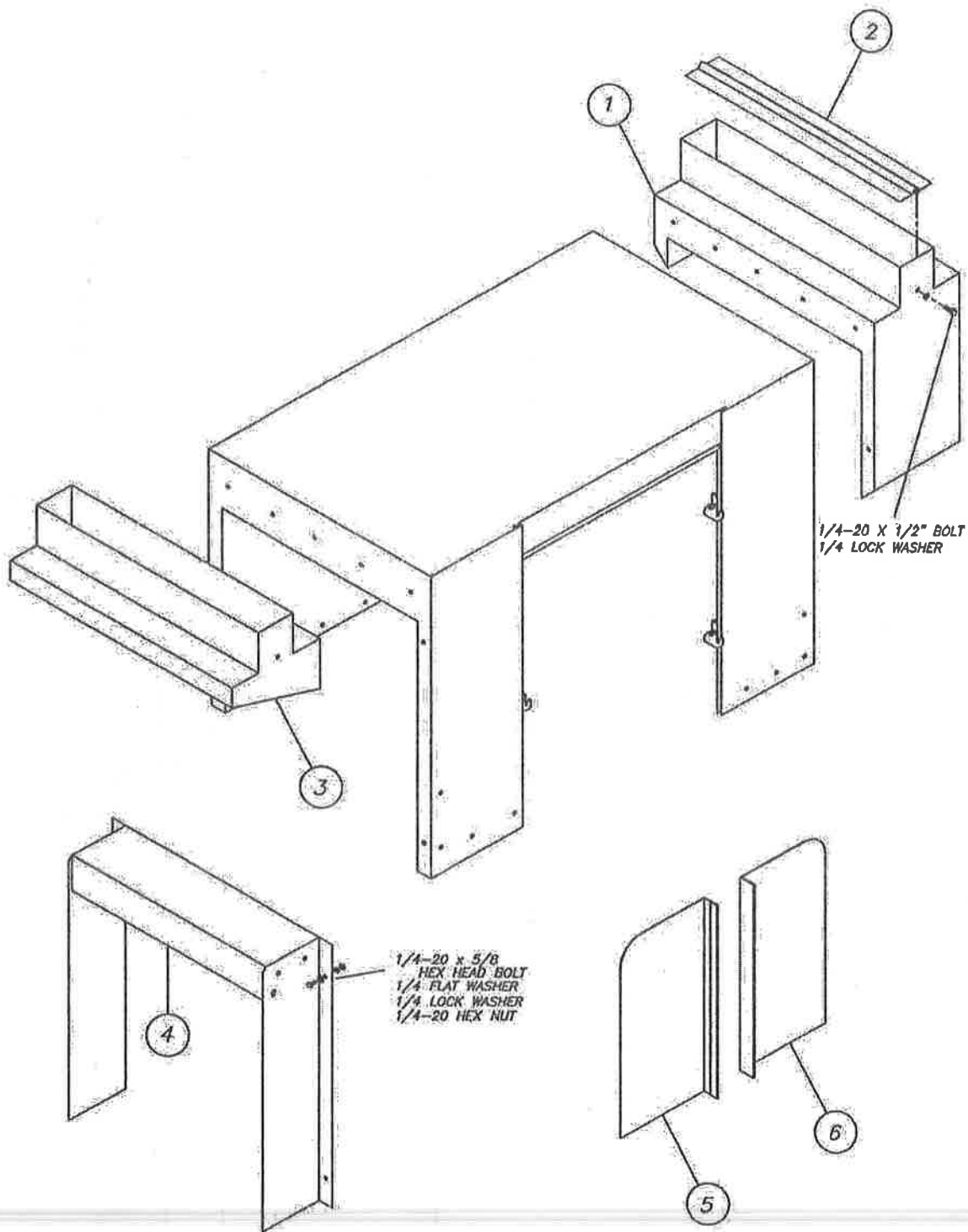



# CURTAINS & RODS

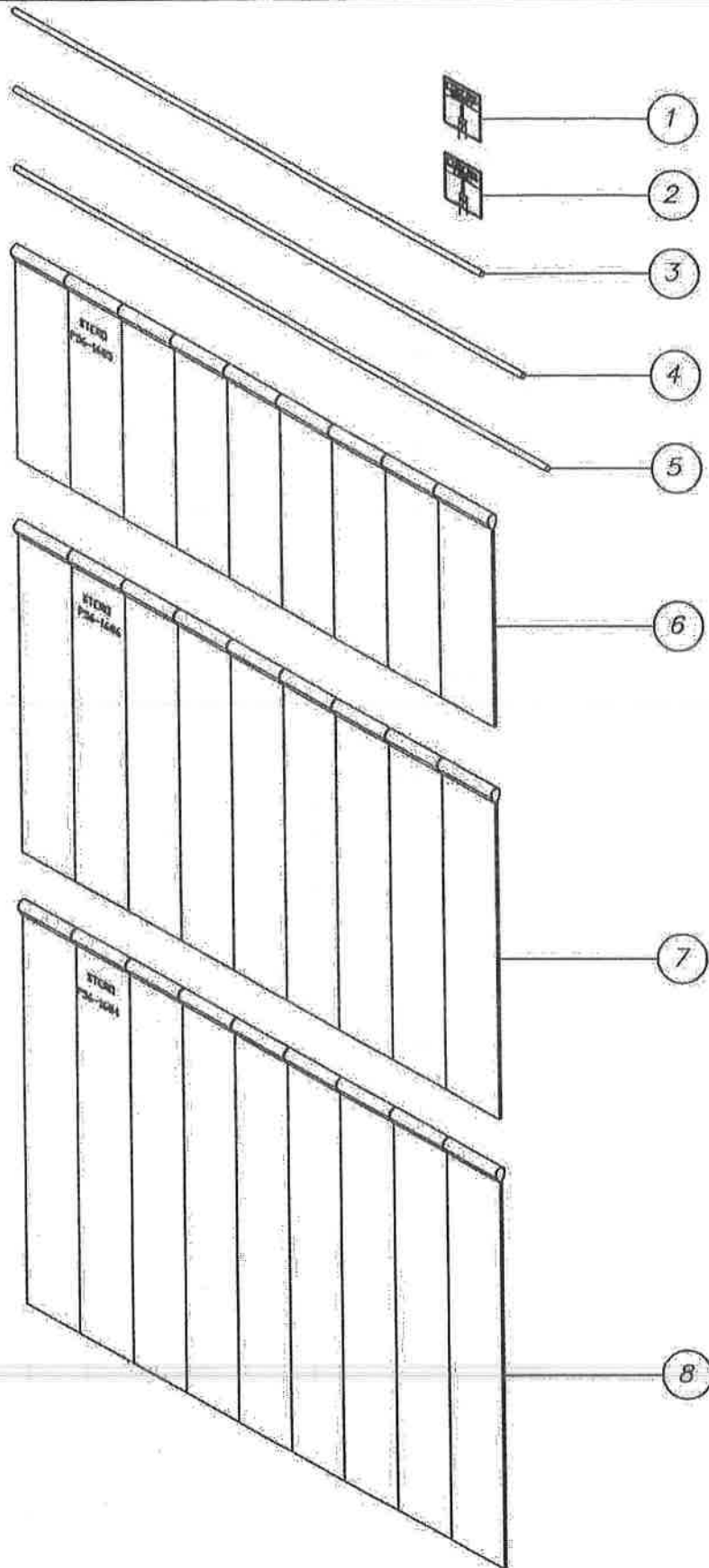

## CURTAINS & RODS

ITEM	DESCRIPTION	REMARKS	REQ.	PART NO.
1	DECAL CURTAIN SHORT			A69-1974
2	DECAL CURTAIN LONG			A69-1975
3	ROD CURTAIN SLOTTED 22-1/4 X 1/4" DIA. (HOOD EXTENSION)			A10-2213
4	ROD CURTAIN 24-1/8 X 1/4" DIA. (STANDARD)			A10-2202
5	ROD CURTAIN SLOTTED 25-1/4 X 1/4" DIA. (VENT COWL)			A10-3293
6	CURTAIN SHORT SCT SIZE "D" 22-5/8 X 9"			P56-1685
7	NO LONGER AVAILABLE. USE P56-1684			P56-1686
8	CURTAIN LONG SCT SIZE "C" 22-5/8 X 17"			P56-1684
	CURTAIN LONG SCT SIZE "E" 22-5/8 X 20"	NOT SHOWN		P56-6949
	CURTAIN EXTRA LONG 22-5/8 X 24" (USE ON MACHINES WITH HOOD EXTENSIONS)	NOT SHOWN		P56-5629
	CURTAIN HOOK (WELDED TO MACHINE)	NOT SHOWN		A10-2677
	PRISON PACKAGE CURTAIN ROD	NOT SHOWN		A10-5185

\* TO ORDER SUPPLY MACHINE MODEL AND SERIAL NUMBER

# RAC-27 SIDE LOADER

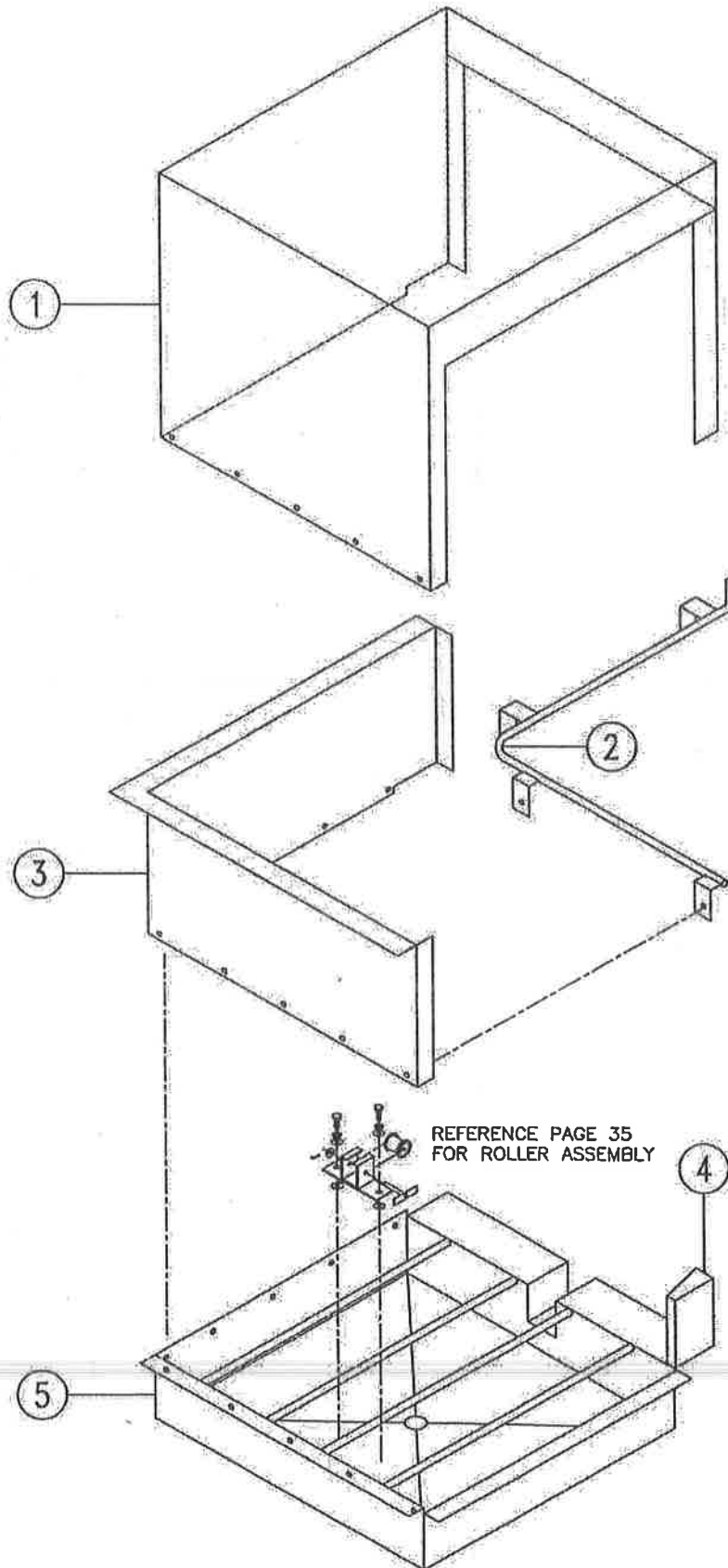

REFERENCE PAGE 35  
FOR ROLLER ASSEMBLY



### RAC-27 SIDE LOADER

ITEM	DESCRIPTION	REMARKS	REQ.	PART NO.
1	HOOD	(OPTIONAL)		*
2	RACK GUIDE ROD			B10-1514
3	SPLASH GUARD			*
4	RACK GUIDE WEDGE			*
5	TANK			*
	COMPLETE RAC-27 SIDE LOADER L-R			A10-4430
	WITHOUT HOOD			
	COMPLETE RAC-27 SIDE LOADER L-R			A10-4431
	WITH HOOD			
	COMPLETE RAC-27 SIDE LOADER R-L			A10-7120
	WITHOUT HOOD			
	COMPLETE RAC-30 SIDE LOADER L-R			A10-7121
	WITHOUT HOOD			
	COMPLETE RAC-30 SIDE LOADER R-L			A10-7122
	WITHOUT HOOD			
	COMPLETE RAC-32 SIDE LOADER L-R			A10-7123
	WITHOUT HOOD			
	COMPLETE RAC-32 SIDE LOADER R-L			A10-7124
	WITHOUT HOOD			

\* TO ORDER SUPPLY MACHINE MODEL AND SERIAL NUMBER

# SIDE LOADER PARTS

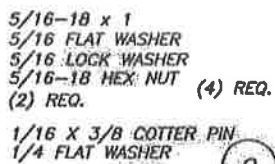
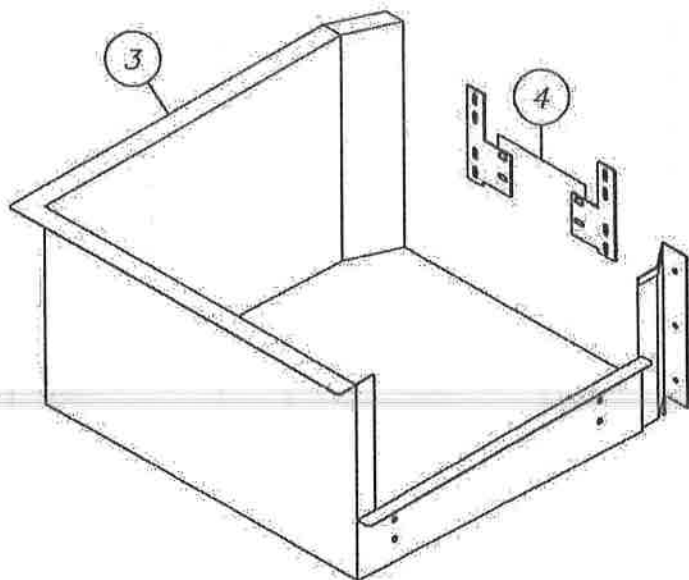
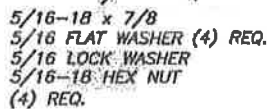
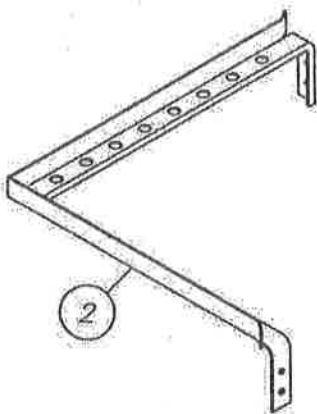
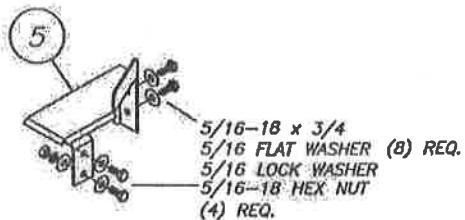
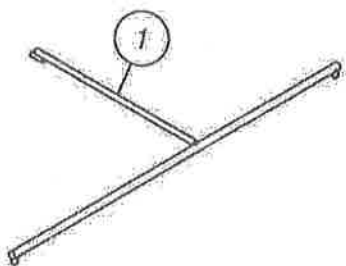

## SIDE LOADER PARTS

ITEM	DESCRIPTION	REMARKS	REQ.	PART NO.
1	BRACKET, RACK SUPPORT L-R	RAC-27	1	A10-7061
1	BRACKET, RACK SUPPORT R-L	RAC-27	1	A10-7062
1	BRACKET, RACK SUPPORT L-R	RAC-30	1	A10-7063
1	BRACKET, RACK SUPPORT R-L	RAC-30	1	A10-7064
1	BRACKET, RACK SUPPORT L-R	RAC-32	1	A10-7065
1	BRACKET, RACK SUPPORT R-L	RAC-32	1	A10-7066
2	TRACK L-R	RAC-27	1	B10-7088
2	TRACK R-L	RAC-27	1	B10-7089
2	TRACK L-R	RAC-30	1	B10-7090
2	TRACK R-L	RAC-30	1	B10-7091
2	TRACK L-R	RAC-32	1	B10-7092
2	TRACK R-L	RAC-32	1	B10-7093
3	SIDE LOADER TANK L-R	RAC-27	1	B10-7076
3	SIDE LOADER TANK R-L	RAC-27	1	B10-7077
3	SIDE LOADER TANK L-R	RAC-30	1	B10-7078
3	SIDE LOADER TANK R-L	RAC-30	1	B10-7079
3	SIDE LOADER TANK L-R	RAC-32	1	B10-7080
3	SIDE LOADER TANK R-L	RAC-32	1	B10-7081
4	BRACKET, JOINER	ALL	2	A10-7106
5	RACK SHELF L-R	RAC-27	1	A10-7094
5	RACK SHELF R-L	RAC-27	1	A10-7095
5	RACK SHELF L-R	RAC-30	1	A10-7096
5	RACK SHELF R-L	RAC-30	1	A10-7097
5	RACK SHELF L-R	RAC-32	1	A10-7098
5	RACK SHELF R-L	RAC-32	1	A10-7099
6	ROLLER BELT	ALL	2	A59-1140
7	STANDOFF, .375 DIA .75 LG	ALL	2	A10-2070
8	BRACKET, GUIDE PAWL BAR	ALL	1	A10-7100
9	ASSY, ROLLER BRACKET	ALL	1	F99-0079

\* TO ORDER SUPPLY MACHINE MODEL AND SERIAL NUMBER

# 368 PUMP & 1-1/2, 2 HP MOTOR

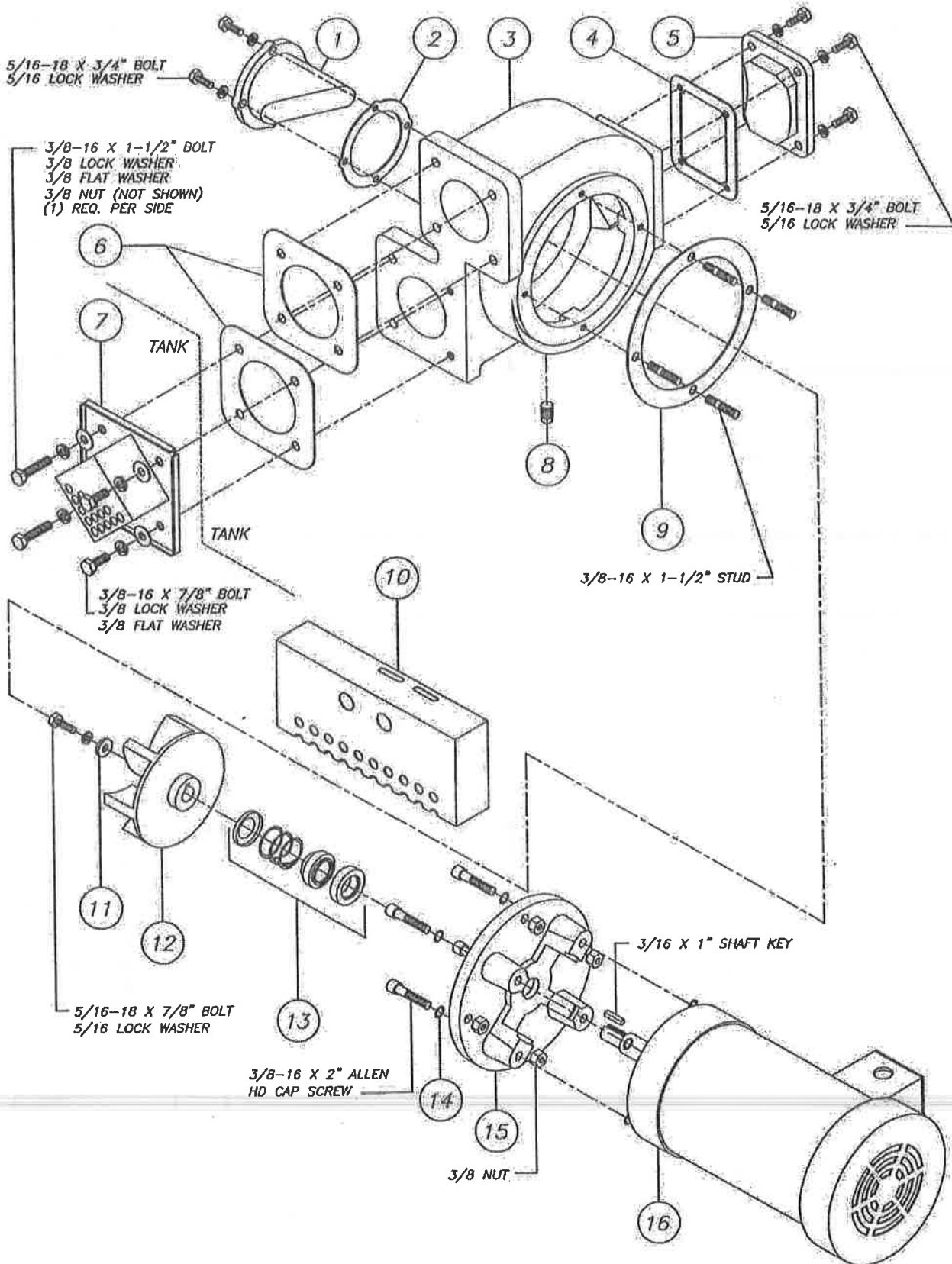

## 368 PUMP & 1-1/2, 2 HP MOTOR

ITEM	DESCRIPTION	REMARKS	REQ.	PART NO.
1	COVER CLEAN OUT #371			A10-1300
2	GASKET "Z1" ROUND INSPECTION COVER			A57-1755
3	PUMP HOUSING #368			C10-1089
4	GASKET "G" 317 INSPECTION COVER			A57-1754
5	COVER INSPECTION #317			A10-1753
6	GASKET "N" 368 PUMP MOUNTING		2	B57-1757
7	ASSM. PUMP INTAKE SCREEN UNIVERSAL			B10-5763
8	PLUG BI 1/4 MIP			P68-1605
9	GASKET "Z" MOTOR FLANGE LARGE			B57-1756
10	PUMP SUCTION STRAINER			B10-1504
11	WASHER HEAVY FLAT MOTOR END SHAFT TO IMPELLAR			A10-2014
12	IMPELLER SS #375 (2 HORSE)			B10-5488
	IMPELLER SS #311 (1-1/2 HORSE)			B10-5489
13	SEAL SHAFT 1"			P57-1697
14	WASHER SS MOTOR FLANGE		8	P67-1909
15	END BELL #499			C10-1052
	END BELL #498B 1HP MTR. TO 2HP PUMP			C10-2175
16	MOTOR 2HP 208/240/460V 3PH 60HZ			P41-1341
	MOTOR 1-1/2 115/230V 1PH 60HZ			P41-1711
	PUMP HOUSING ASSEMBLY #368 (ASSEMBLY INCLUDES ITEMS 1,2,3,4,5, & 8) NEED TO ORDER (2) ITEM #6, (1) ITEM #9			B10-1752
	COMPLETE 2HP 3PHASE MOTOR WITH 375 IMPELLER (ASSEMBLY INCLUDES ITEMS 11-16) NEED TO ORDER (1) ITEM #9			B10-2179
	COMPLETE 1-1/2HP 1PHASE MOTOR WITH 311 IMPELLER (ASSEMBLY INCLUDES ITEMS 11-16) NEED TO ORDER (1) ITEM #9			B10-2177

\* TO ORDER SUPPLY MACHINE MODEL AND SERIAL NUMBER

( 34 )

# 321 PUMP & 1 HP MOTOR

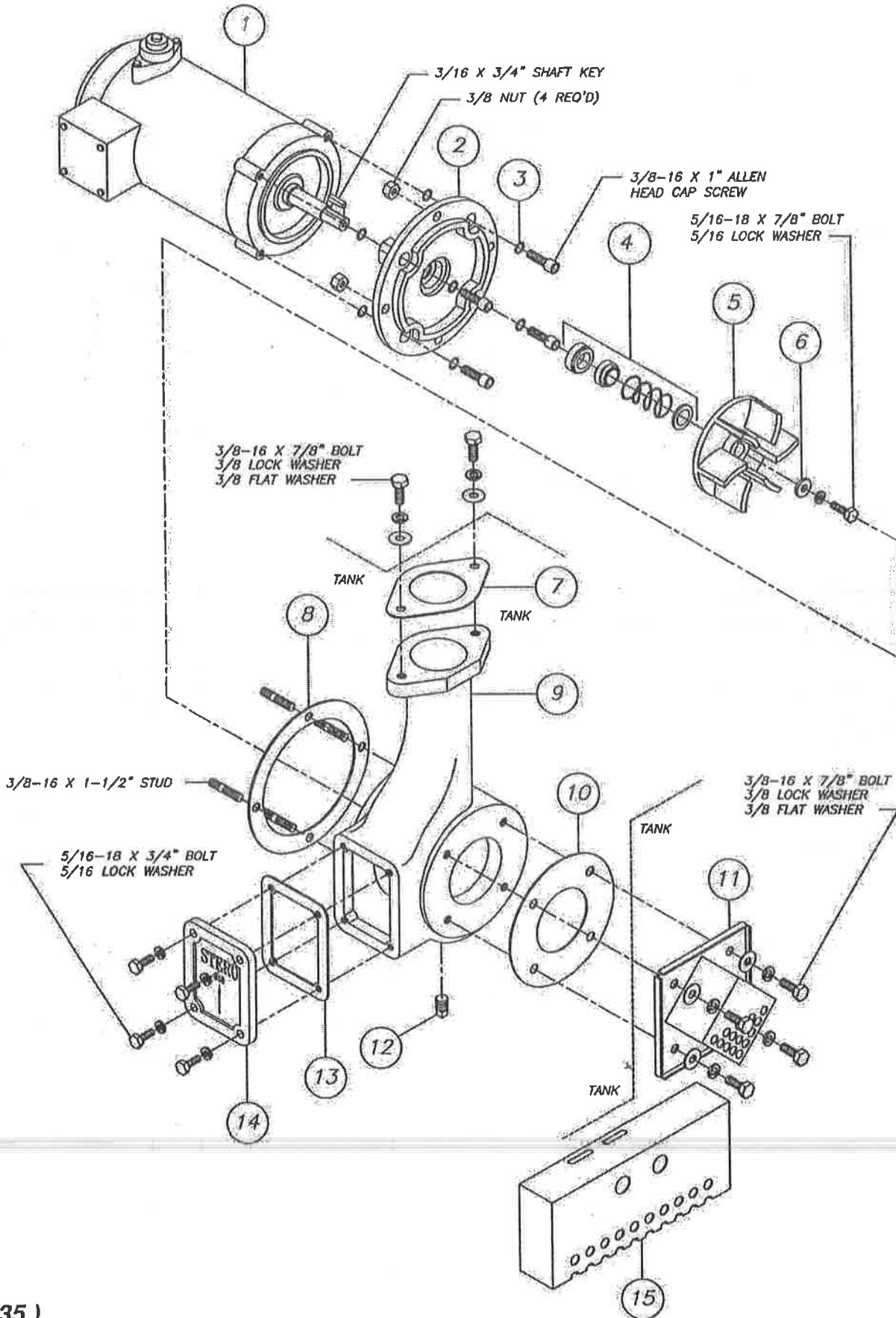

## 321 PUMP & 1 HP MOTOR

ITEM	DESCRIPTION	REMARKS	REQ.	PART NO.
1	MOTOR 1HP 208/230/460 V. 3PH			P41-2220
	MOTOR 1HP 115/230 V. 1PH			P41-2219
2	END BELL #498A 1 HP TO 1 HP PUMP			C10-2173
	END BELL #498B 1 HP TO 2 HP PUMP			C10-2175
3	WASHER SS MOTOR FLANGE		8	P67-1909
4	SEAL SHAFT 3/4"			P57-1696
5	#307 SS IMPELLER			B10-5490
6	WASHER HEAVY FLAT MOTOR END SHAFT TO IMPELLER			A10-2014
7	GASKET "T" 321 PUMP DISCHARGE			B57-2444
8	GASKET "L" MOTOR TO PUMP			B57-2443
9	HOUSING PUMP #321			C10-2440
10	GASKET "S" PUMP SUCTION FLANGE			B57-2442
11	PUMP INTAKE SCREEN UNIVERSAL			B10-5763
12	PLUG 1/4" NPT			P68-1605
13	GASKET "G" 316 & 317 INSPECTION COVER			A57-1754
14	COVER INSPECTION #316			A10-2441
15	PUMP SUCTION STRAINER			B10-1504
	COMPLETE 3 PHASE MOTOR WITH IMPELLAR (ASSEMBLY INCLUDES ITEMS 1,2,3,4,5,6, & MISC. HARDWARE) NEED TO ORDER (1) ITEM #7, 8 & 10			B10-4171
	COMPLETE 1 PHASE MOTOR WITH IMPELLAR (ASSEMBLY INCLUDES ITEMS 1,2,3,4,5,6, & MISC. HARDWARE) NEED TO ORDER (1) ITEM #7, 8 & 10			B10-2185
	PUMP COMPLETE #321 (ASSEMBLY INCLUDES ITEMS 9,12,13, & 14)			B10-2479

\* TO ORDER SUPPLY MACHINE MODEL AND SERIAL NUMBER

# 1/4 HORSE PRICE PUMP

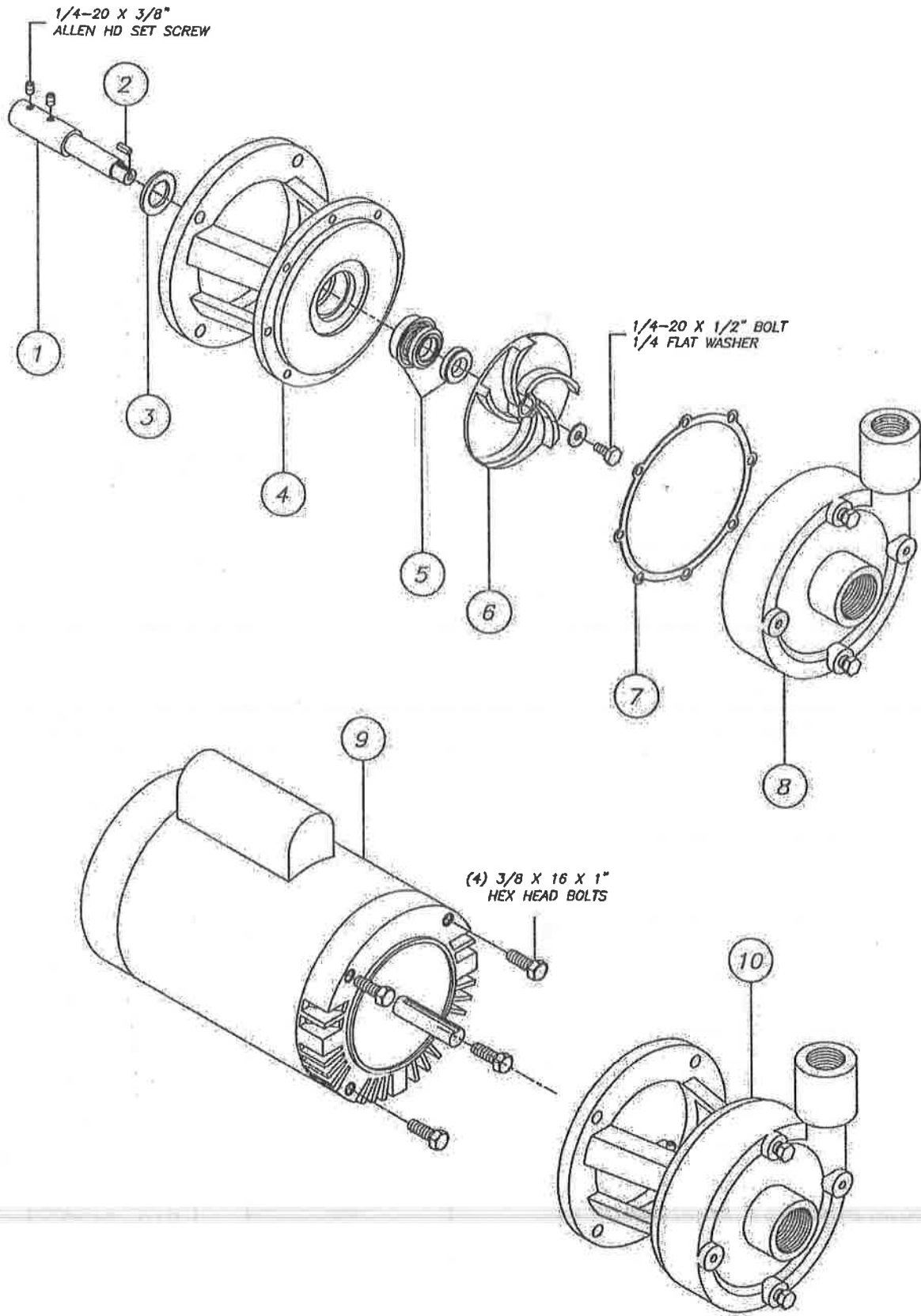



## 1/4 HORSE PRICE PUMP

ITEM	DESCRIPTION	REMARKS	REQ.	PART NO.
1	PUMP COUPLING PRICE PUMP NEW STYLE KEYED SHAFT MOUNT			A10-5913
	PUMP COUPLING PRICE PUMP OLD STYLE THREADED SHAFT MOUNT			A10-2310
2	IMPELLER KEY 1/8 X .40" S.S.			P50-5914
3	SLINGER WASHER			P57-5054
4	NOT SOLD SEPARATELY			
5	SEAL 5/8" PRICE PUMP			P57-1030
6	IMPELLER 1/4 HP PRICE PUMP NEW STYLE KEYED SHAFT MOUNT (5 BLADE)	(5 BLADE)		A41-5911
	IMPELLER 1/4 HP PRICE PUMP OLD STYLE THREADED SHAFT MOUNT	(4 BLADE)		NLA
7	GASKET "2801" PRICE PUMP			B57-1334
8	NOT SOLD SEPARATELY			
9	MOTOR 1/4 HP 115/230 V. 1PH MOTOR 1/4 HP 208/240/480 V. 3PH			P41-5773 P41-2218
10	PRICE PUMP 1/4 HP COMPLETE (NO MOTOR)			P41-1028
	FIRST GEN ER-44 & ER-66S	NOT SHOWN		
	STAINLESS STEEL 1/4 HP PRICE PUMP	COMPLETE		P41-6346
	GASKET, WHITE TEFLON SHADE			P57-6819
	SEAL			P57-6501
	IMPELLER			A41-6347
	MOTOR			P41-2218
	COUPLING			P41-6820
	SLINGER WASHER			P57-5054
	SHAFT KEY			P50-5914

\* TO ORDER SUPPLY MACHINE MODEL AND SERIAL NUMBER

(38)

# ER 1/3 HP PUMP AND MOTOR ASSEMBLY

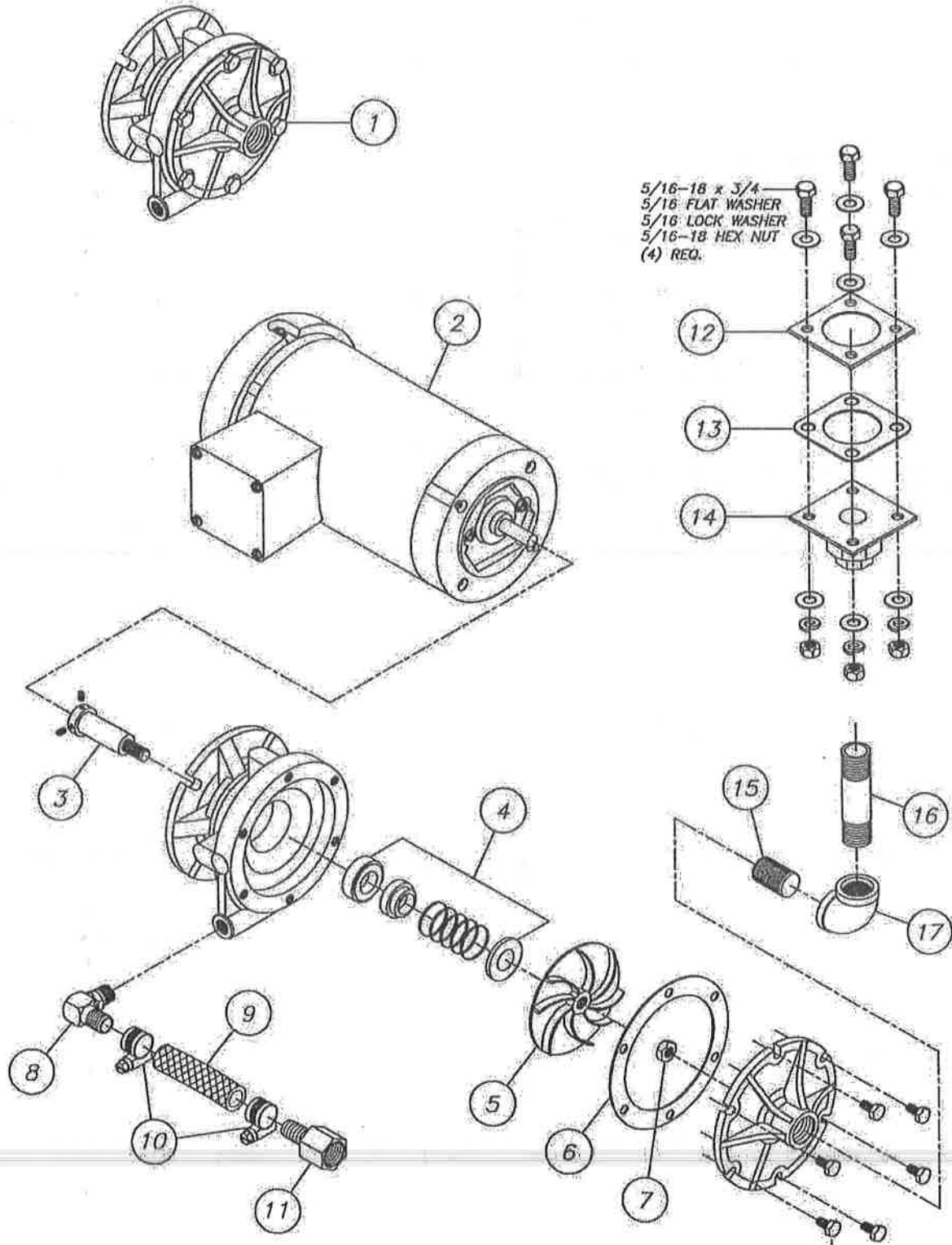

## ER 1/3 HP PUMP AND MOTOR ASSEMBLY

ITEM	DESCRIPTION	REMARKS	REQ.	PART NO.
1	1/3 HP PUMP ASSEMBLY LESS MOTOR			P41-6367
2	MOTOR 1/3 HP 208-230/480V. 3PH.			P41-6381
3	PUMP SHAFT WITH SET SCREWS			P41-6503
4	5/8" PUMP SEAL 1/3 HP PUMP			P57-6501
5	PUMP IMPELLER			A41-6369
6	PUMP HOUSING GASKET			P57-6502
7	IMPELLER JAM NUT			P41-6504
8	ELBOW 90 SS .25 MNPT X .5 BARD			P68-6515
9	PUMP DISCHARGE TUBING 1/2 D X 1/8 W	20" PIECE		P51-6498
10	HOSE CLAMP			P60-5952
11	ADAPTOR SS .5 FNPT X .5 BRAD			P68-6514
12	UNION PLATE 5/8" OD			A10-1370
13	UNION PLATE GASKET			A57-1419
14	ASSY. 1/2" SS UNION WELDED TO FLANGE			A10-6431
15	1/2" SS CLOSE NIPPLE			P68-1885
16	1/2" X 3" SS NIPPLE			P68-6619
17	1/2" SS ELBOW			P68-1887
	PUMP & MOTOR COMPLETE			C41-6366

\* TO ORDER SUPPLY MACHINE MODEL AND SERIAL NUMBER

# MOTOR & GEAR BOX DRIVE ASSM.Y

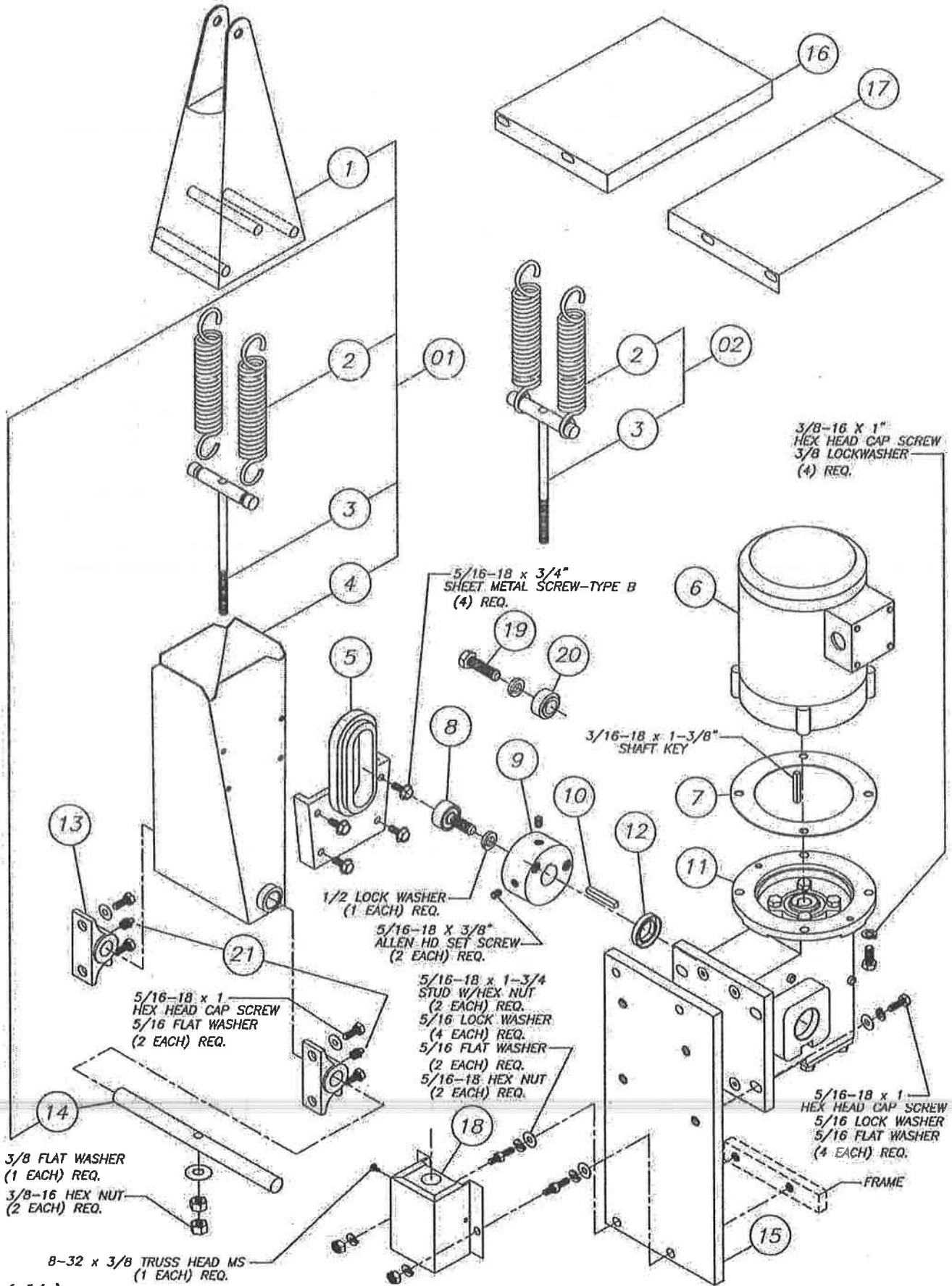

## MOTOR & GEAR BOX DRIVE ASSM.Y

ITEM	DESCRIPTION	REMARKS	REQ.	PART NO.
01	ASSY, COMPLETE CONVEYOR RELEASE HOUSING	INCLUDES ITEMS: 1, 2, 3, 4, & 14	1	B10-1940
02	ASSY, CONV. RELEASE SPRING/TENSION BAR	INCLUDES ITEMS 2&3	1	B10-6243
1	RELEASE HOUSING UPPER HALF		1	A10-1942
2	SPRING CONVEYOR RELEASE		2	A60-1104
3	TENSION BAR CONVEYOR RELEASE		1	A10-1234
4	RELEASE HOUSING LOWER HALF		1	A10-1941
5	FOLLOWER DRIVEARM - ECCENTRIC CAM	CASTING #1104	1	A10-1948
6	MOTOR 1/4 HP 208/230/460 V. 3 PH.		1	P41-2218
	MOTOR 1/4 HP 115/230 V. 1 PH.		1	P41-5773
7	GASKET CONVEYOR MOTOR/GEAR BOX		1	A57-1020
8	BEARING CONV. ECCENTRIC & IDLER WHEEL	INCLUDES # 19&20	1	P66-6337
9	ECCENTRIC CONVEYOR DRIVE		1	B10-1304
10	SHAFT KEY 1/4" SS		1	P50-1338
11	GEAR BOX 73:1 RIGHT HAND		1	P58-1215
	GEAR BOX 73:1 LEFT HAND	(SHOWN)	1	P58-1216
	GEAR BOX 60:1 RIGHT HAND		1	P58-1333
	GEAR BOX 60:1 LEFT HAND		1	P58-1334
	GEAR BOX 50:1 RIGHT HAND		1	P58-1335
	GEAR BOX 50:1 LEFT HAND		1	P58-1336
	GEAR BOX 100:1 LEFT HAND		1	P58-5447
12	OUTPUT SHAFT SEAL (WINDSMITH)		1	P57-5899
	GEAR BOXES USE:	SAE 90 WT. OIL		
13	BEARING JOURNAL W/FITTING		2	A10-1939
14	CROSS SHAFT CONVEYOR RELEASE		1	A10-1233
15	PLATE MOUNTING GEAR BOX		1	*B10-1949
16	MOTOR SPLASH GUARD L>R MACHINE	SCT44CS / 66CS	1	A10-2077
17	MOTOR SPLASH GUARD R>L MACHINE	SCT44CS / 66CS	1	A10-2078
18	TABLE LIMIT SWITCH CONNECTION POINT BOX		1	A10-6312
19	1/2" X 13 X 1-3/4" BOLT FOR ECCENTRIC		1	P67-2079
20	BEARING ONLY FOR ECCENTRIC		1	P66-1207
21	ZIRK FITTING FOR JOURNAL BEARING		1	P66-1221
	GEARBOX "L" BRACKET L-R FEED		1	A10-2702
	GEARBOX "L" BRACKET R-L FEED		1	A10-2703
	GEARBOX LOWER BRACKET/BAR		1	A10-3719
	CONVEYOR REALEASE MOUNTING BRACKET		1	A10-3718

\* TO ORDER SUPPLY MACHINE MODEL AND SERIAL NUMBER

( 42 )

# STRAIGHT DRIVE SECTION ASSEMBLY

SCT - SC

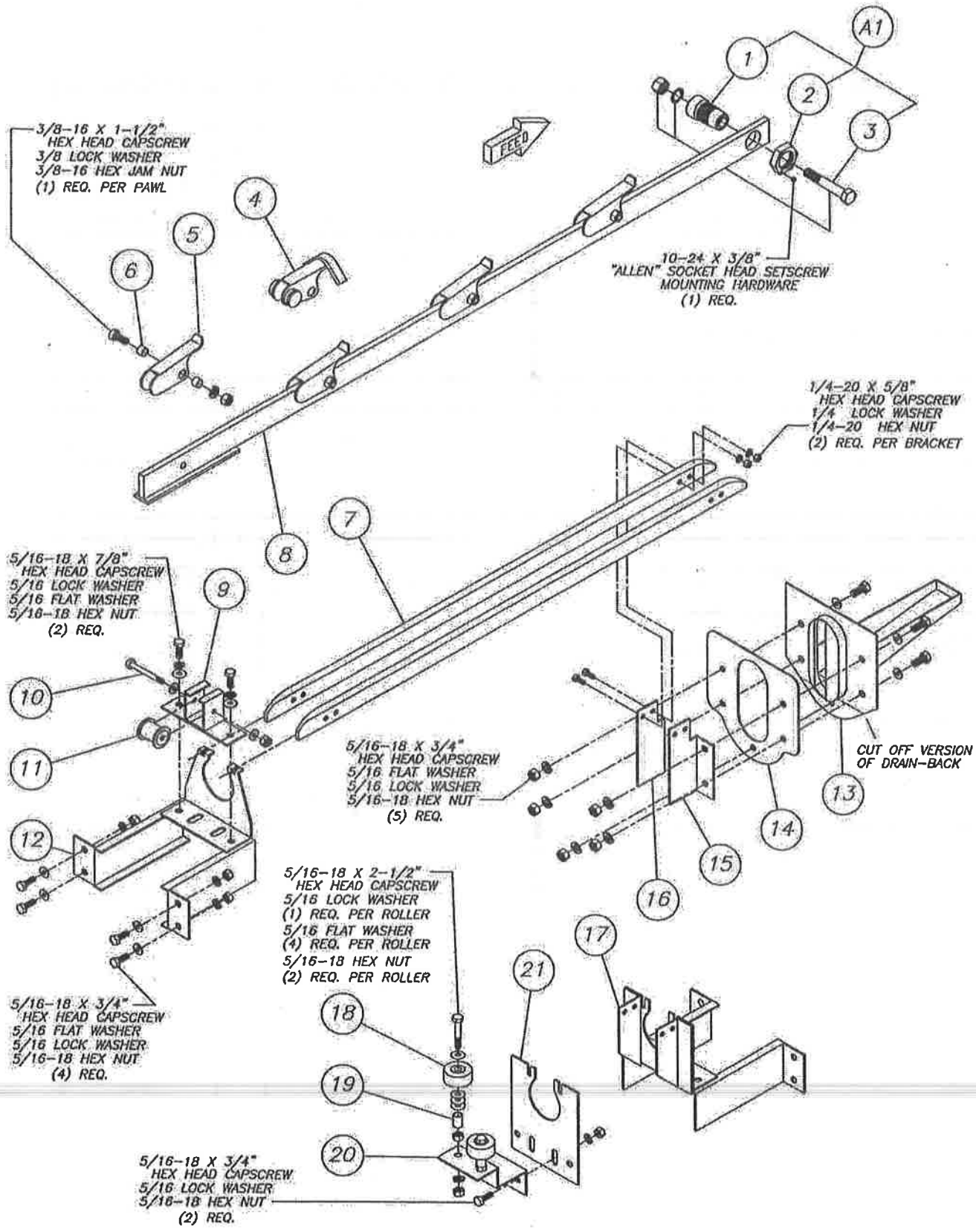

STRAIGHT DRIVE SECTION ASSEMBLY  
SCT - SC

ITEM	DESCRIPTION	REMARKS	REQ.	PART NO.
A1	COUPLING ASSY. PAWL BAR TO RLS. HOUSING	INCLUDES 1-2-3	1	A10-1943
1	CONVEYOR BAR BEARING WITH INSERT		1	A10-2637
		NEEDLE BEARING		P66-2280
	MODULARS	ON CURVE		A10-6770
2	LOCKNUT CONVEYOR BAR BEARING		1	A10-1213
3	MNTG. HARDWARE, CONVEYOR BAR PIVOT BRNG.	BOLT-LOCK WASHR-NUT	1	P67-2078
4	PAWL CORNER		1	B10-1274
5	PAWL CONVEYOR DRIVE STAND		1	B10-1273
6	PAWL BUSHING S.S.		2	A51-1095
7	GUIDE RAIL - SCT-44CS	LINE #7 NOTE:	2	B10-1945
	GUIDE RAIL - SCT-64-66S-CS	IF MACHINE IS	2	B10-2604
	GUIDE RAIL - SCT-76-76S	NOT NOTED	2	B10-2605
	GUIDE RAIL - SCT-94-94S	CALL FACTORY	2	B10-2606
	GUIDE RAIL - SCT-120		2	B10-2608
	GUIDE RAIL - SCT-44-44CSA		2	B10-2720
	GUIDE RAIL - SCT-66S-S-CSA		2	B10-2721
	GUIDE RAIL - SC-5-6-7-8		2	B10-3626
8	PAWL BAR - SCT-66S-CS	LINE #8 NOTE:	1	B10-1272
	PAWL BAR - SCT-44CS	IF MACHINE IS	1	B10-1944
	PAWL BAR - SCT-64	NOT NOTED	1	B10-2598
	PAWL BAR - SCT-76	CALL FACTORY	1	B10-2599
	PAWL BAR - SCT-94		1	B10-2600
	PAWL BAR - SCT-108S		1	B10-2601
	PAWL BAR - SCT-120S & SC		1	B10-2602
	PAWL BAR - SCT-76SC		1	B10-3760
	PAWL BAR - SCT-66SC		1	*
9	ASSEMBLY, BRACKET, CONVEYOR ROLLER		1	A10-1280
10	MNTG. HARDWARE, CONVEYOR ROLLER	BOLT-WASHR-NYLOK NUT	1	A10-1281
11	ROLLER CONVEYOR BAR		1	A59-1202
12	ASSEMBLY, BRACKET		1	B10-3684
13	DRAIN-BACK (STANDARD)-(CUT OFF VERSION)		1	B10-1285
14	GASKET "Q" DRAIN-BACK		1	A57-2079
15	BRACKET RAIL SUPPORT (LEFT HAND)		1	A10-1946
16	BRACKET RAIL SUPPORT (RIGHT HAND)		1	A10-1947
17	ASSEMBLY, BRACKET		1	B10-3687
18	ROLLER (CELCON)		2	A59-1140
19	SPACER		2	A10-2070
20	BRACKET CENTER GUIDE DUAL ROLLER		1	B10-2610
21	BRACKET CENTER GUIDE SUPPORT YOKE		1	B10-2609

\* TO ORDER SUPPLY MACHINE MODEL AND SERIAL NUMBER

(44)

# CURVED DRIVE SECTION ASSEMBLY

SCT - SC

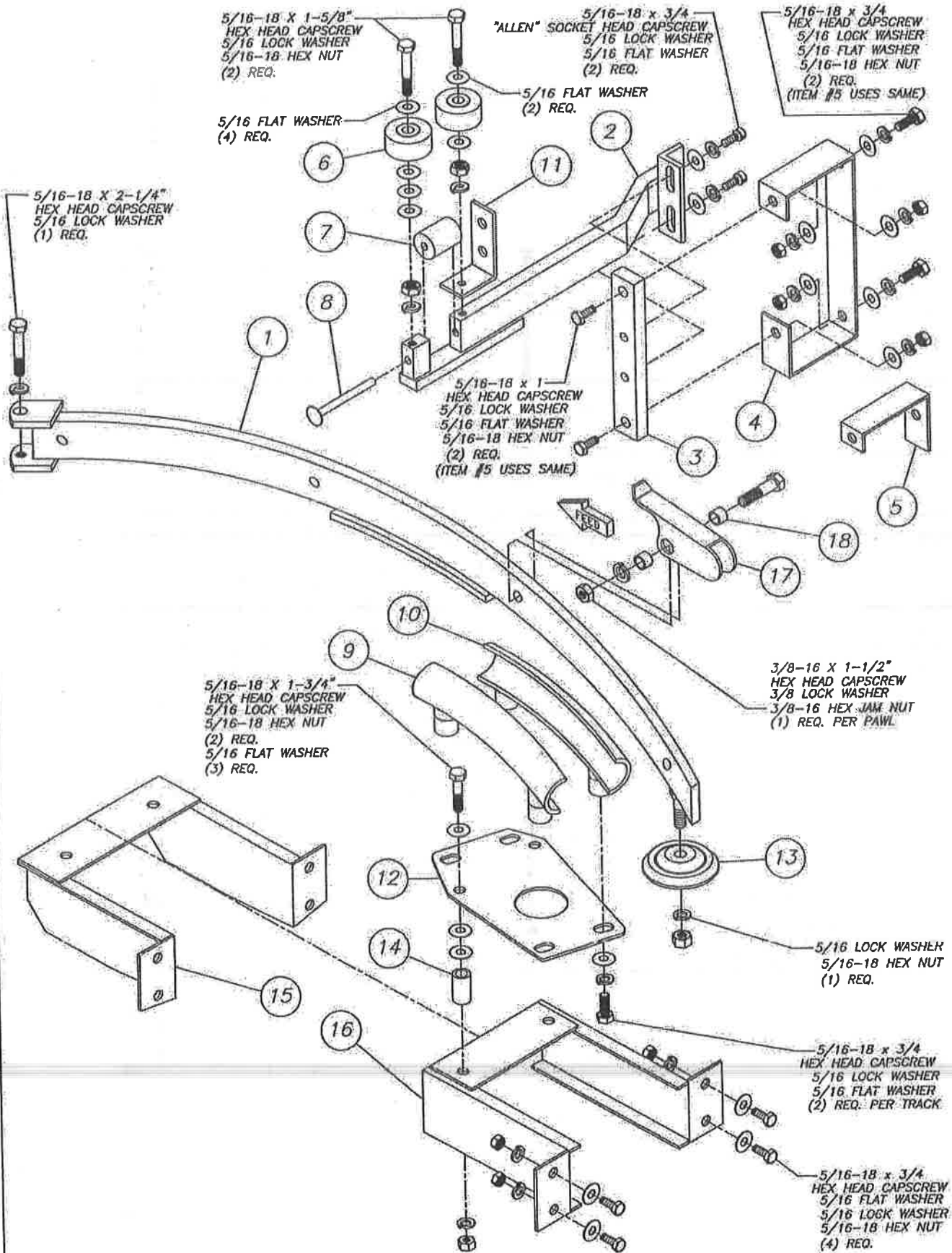



### CURVED DRIVE SECTION ASSEMBLY SCT - SC

ITEM	DESCRIPTION	REMARKS	REQ.	PART NO.
1	PAWL BAR CURVED		1	B10-2630
2	BRACKET SUPPORT WHEEL	SEE NOTE	1	B10-2632
3	SUPPORT BAR		1	A10-6943
4	BRACKET SUPPORT BAR SC-9 ONLY		1	*
5	BRACKET SUPPORT BAR		1	A10-3667
6	ROLLER (CELCON)		2	A59-1140
7	ROLLER LOWER CONVEYOR GUIDE		1	A59-1317
8	SHAFT SUPPORT WHEEL		1	A10-2631
9	TRACK INNER GUIDE WHEEL		1	A10-2634
10	TRACK OUTER GUIDE WHEEL		1	A10-2635
11	BRACKET, GUIDE	W /O. POST	1	A10 5270
12	PLATE TRACK MOUNTING	REMARK / INFO	1	A10-2636
13	ROLLER (STAINLESS STEEL)	REMARK / INFO	1	A10-1813
14	SPACER TRACK	REMARK / INFO	2	A10-1899
15	BRACKET CONVEYOR BAR END REST	SC-9	1	B10-3806
16	BRACKET CONVEYOR BAR END REST		1	B10-1277
17	PAWL CORNER	SC-9	1	B10-1274
18	PAWL CONVEYOR DRIVE STAND	SC-9	1	B10-1273
19	PAWL BUSHING S.S.		2	A51-1095
NOTE: A10-2633 NOW PART OF B10-2632				

\* TO ORDER SUPPLY MACHINE MODEL AND SERIAL NUMBER

# PAWL BARS and RAILS

SCT - SC

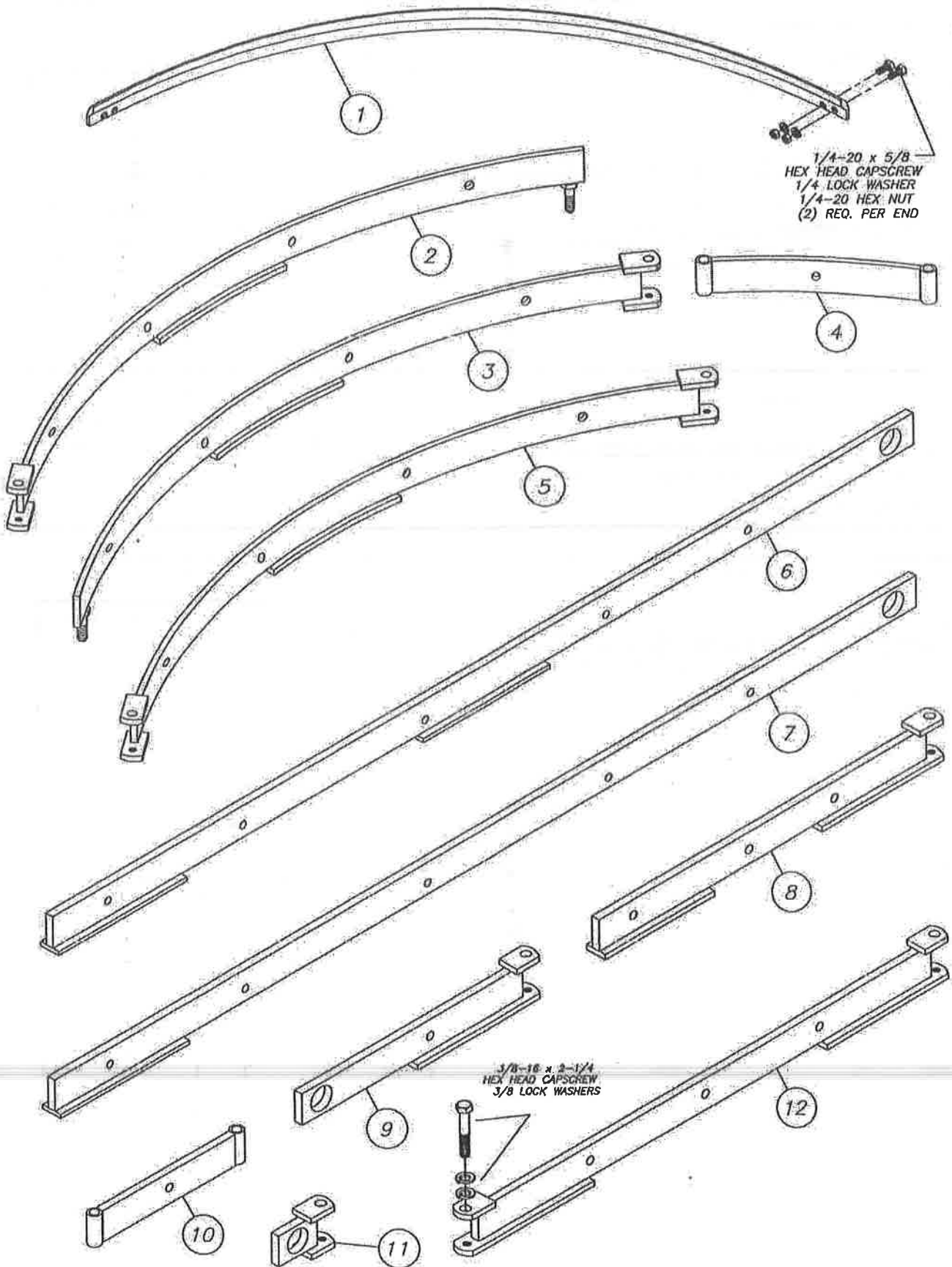

**PAWL BARS and RAILS**  
SCT - SC

ITEM	DESCRIPTION	REMARKS	REQ.	PART NO.
1	GUIDE RAIL CURVED SECTION	SC-1-2-3	1	*B10-1945
2	PAWL BAR CURVED SECTION	SC-1-2-3 R to L	1	*B10-2630
3	PAWL BAR CURVED SECTION	SC-1-2-3 L to R	1	*B10-2630
4	PAWL BAR 6-3/4" CURVED LINK	WITHOUT HOLE	1	B10-2623
	PAWL BAR 8-1/2" CURVED LINK	WITH HOLE	1	B10-2627
	PAWL BAR 10-5/8" CURVED LINK	WITH HOLE	1	B10-2629
5	PAWL BAR SC CURVED CENTER SECTION	CLEVIS BOTH ENDS	1	B10-2626
6	PAWL BAR STRAIGHT SECTION	SCT-94-120	1	*C10-1282
7	PAWL BAR STRAIGHT SECTION		1	*
8	PAWL BAR STRAIGHT SECTION	LR or RL	1	*B10-3814
9	PAWL BAR STRAIGHT SECTION	SC-4 LR or RL	1	B10-2622
10	PAWL BAR 8-1/2" STRAIGHT LINK	WITH HOLE	1	B10-2624
	PAWL BAR 10-5/8" STRAIGHT LINK	WITH HOLE	1	B10-2628
11	PAWL BAR STRAIGHT SECTION	SC-9	1	*A10-3826
12	PAWL BAR 25-1/8" STRAIGHT SECTION	CLEVIS BOTH ENDS	1	B10-3815

\* TO ORDER SUPPLY MACHINE MODEL AND SERIAL NUMBER

# DWELL UNIT ASSEMBLY

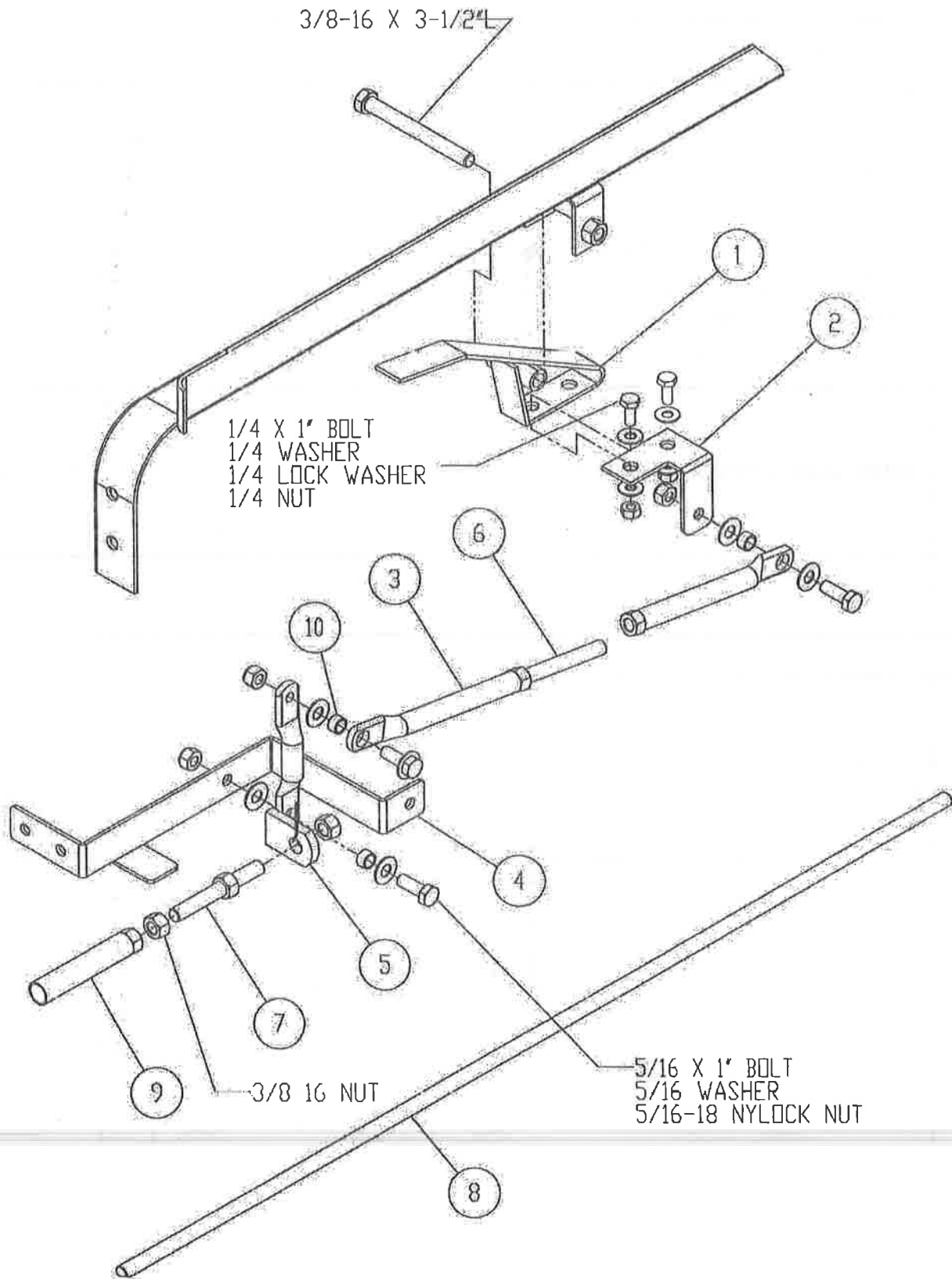



# TYPICAL TANK ASSEMBLY

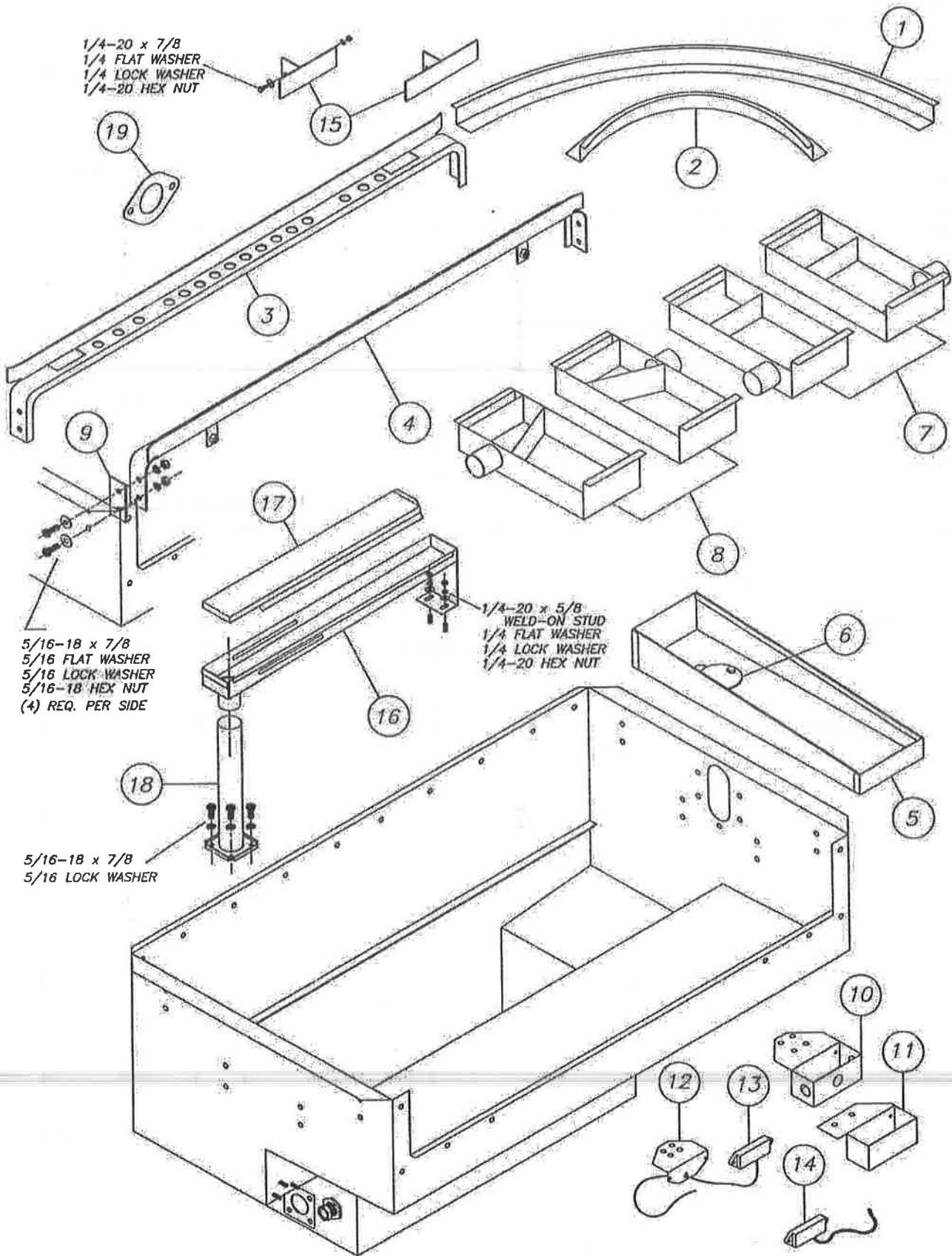

# TYPICAL TANK ASSEMBLY

ITEM	DESCRIPTION	REMARKS	REQ.	PART NO.
1	TRACK REAR SC-1, 2, 3, & 9 SPECIFY MODEL, SERIAL & WHICH TANK			B10-3610
2	TRACK FRONT SC-1, 2, 3, & 9 MODEL, SERIAL NO. & SPECIFIC WHICH TANK WHEN ORDERING TRACKS			B10-3609
3	TRACK REAR			*
4	TRACK FRONT			*
5	RINSE SAVER PAN			B10-2560
6	DIVERTER RINSE SAVER PAN			A10-2559
7	DRAIN PAN SCT-66S L-R OR R-L	SPECIFY		F99-0098
8	DRAIN PAN SCT-76SC ONLY L-R OR R-L	SPECIFY		*
9	TRACK SHIM			A10-4566
10	COVER/MOUNTING BRACKET REED SWITCH	STANDARD		A10-5298
11	COVER/MOUNTING BRACKET REED SWITCH			A10-5450
12	BRACKET MOUNTING REED SWITCH SCT-66S-CS OR SCT-66S-CSA L>R	STANDARD		A10-4273
	AUTO START ONLY (NOT SHOWN)			A10-4272
13	REED SWITCH WITH GRAY CORD			B10-4274
14	REED SWITCH WITH BLACK SJ CORD			B10-5595
15	SC TRACK DEFLECTOR BRACKET SPECIFY MODEL OF MACHINE AND FEED DIRECTION ALSO LOCATION OF BRACKET.			A10-3341
	USED ON SCT-44 MACHINES AFTER 2008			
16	SCT-44 CARRYOVER FINAL RINSE TROUGH			A10-6684
17	SCT-44 CARRYOVER FINAL RINSE TROUGH COVER			A10-6685
18	SCT-44 OVERFLOW STANDPIPE			A10-6685
19	GASKET BETWEEN TANKS MODULAR MACHINES			B57-2444
	MERCURY SWITCHES ARE NO LONGER AVAILABLE			

\* TO ORDER SUPPLY MACHINE MODEL AND SERIAL NUMBER

# LEVERS & BRACKETS

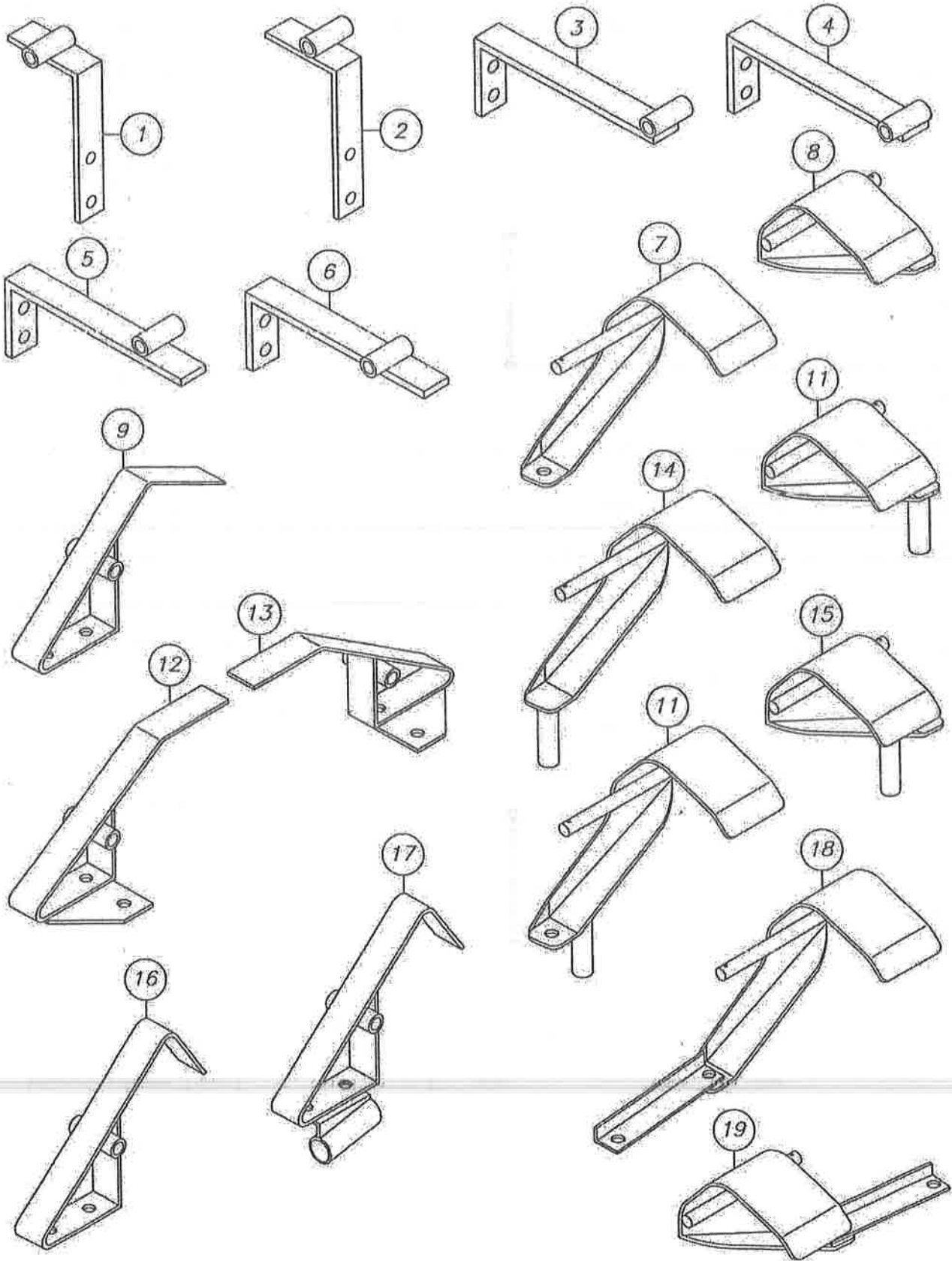



## LEVERS & BRACKETS

THE FACTORY REQUIRES MODEL & SERIAL NUMERS WITH ALL OF  
THE PARTS ON THIS PAGE.

ITEM	DESCRIPTION	REMARKS	REQ.	PART NO.
1	BRACKET, START LEVER - 76SC-120SC	LEFT>RIGHT		*
2	BRACKET, START LEVER - 76SC-120SC	RIGHT>LEFT		*
3	BRACKET, FINAL RINSE LEVER #4 OFF #2-3	LEFT>RIGHT		*
4	BRACKET, FINAL RINSE LEVER #4 OFF #2-3	RIGHT>LEFT		*
5	BRACKET, START LEVER #5 OR 6	LEFT>RIGHT		*
	BRACKET, START LEVER #1 OR 2	RIGHT>LEFT		*
6	BRACKET, START LEVER #5 OR 6	RIGHT>LEFT		*
	BRACKET, START LEVER #1 OR 2	LEFT>RIGHT		*
7	LEVER, FINAL RINSE #9	LEFT>RIGHT		B10-3312
8	LEVER, FINAL RINSE #9	RIGHT>LEFT		B10-3310
9	LEVER, START 44 & 44CSA			B10-1980B
10	LEVER, START #5 OR 6	RIGHT>LEFT		B10-3312
	LEVER, FINAL RINSE #4 OFF #2-3	LEFT>RIGHT		
11	LEVER, START #5 OR 6	LEFT>RIGHT		B10-3310
	LEVER, FINAL RINSE #4 OFF #2-3	RIGHT>LEFT		
12	LEVER, FINAL RINSE 66SCS & 44CS	LEFT>RIGHT		B10-1982
13	LEVER, FINAL RINSE 66SCS & 44CS	RIGHT>LEFT		B10-1983
14	LEVER, START #1 OR 2	LEFT>RIGHT		B10-3312
15	LEVER, START #1 OR 2	RIGHT>LEFT		B10-3310
16	LEVER, FINAL RINSE STRAIGHT THRU			B10-1980A
	CONVEYOR (NOT FOR USE ON 44CS OR 66S-CS)			
	LEVER, FINAL RINSE #4 OFF #6 OR 7			
	LEVER, START SCT-44CS - 120S			
17	LEVER, START SCT-66S - SCT-66SCS	LEFT>RIGHT		B10-1980A
18	LEVER, START - CORNER SCRAP TANKS	RIGHT>LEFT		B10-3312
19	LEVER, START - CORNER SCRAP TANKS	LEFT>RIGHT		B10-3310
	* CALL FACTORY WITH MODEL & SERIAL NUMBERS (800) 762-7600			

\* TO ORDER SUPPLY MACHINE MODEL AND SERIAL NUMBER

# START & RINSE STYLE LEVER ASSEMBLIES

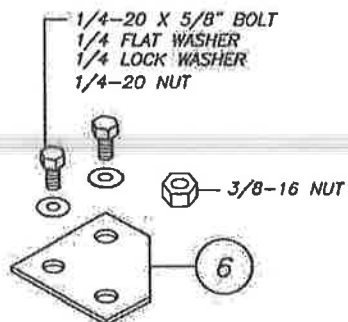
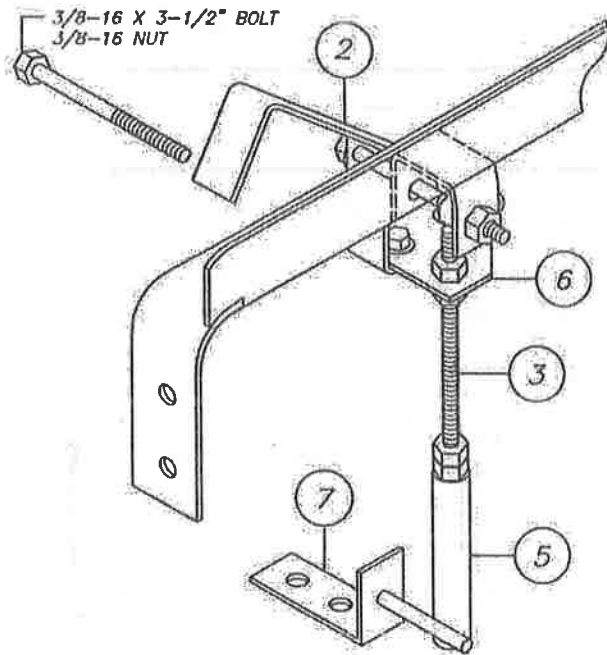
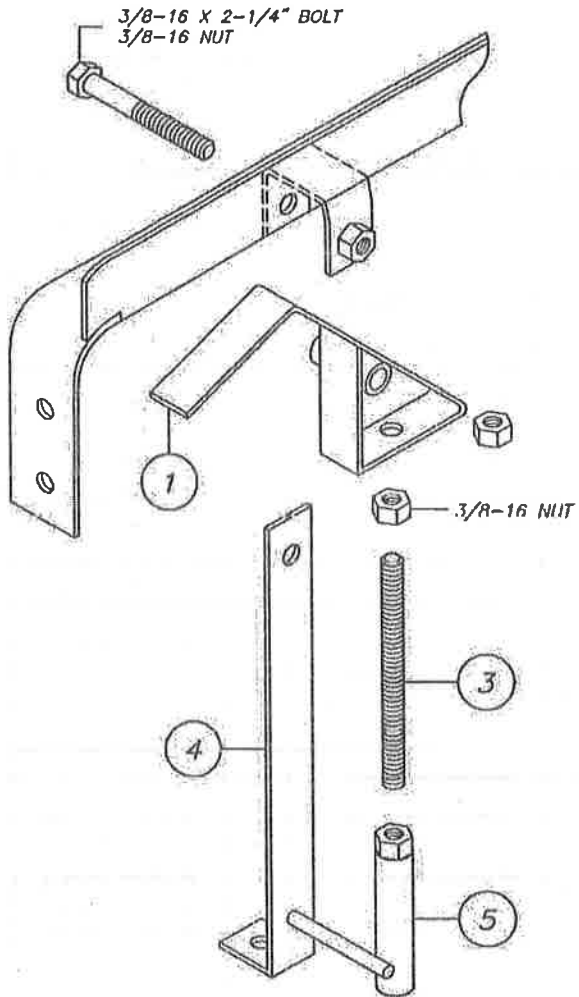



# RACK SWITCH LEVER ASSEMBLY

SCT - CONVEYOR

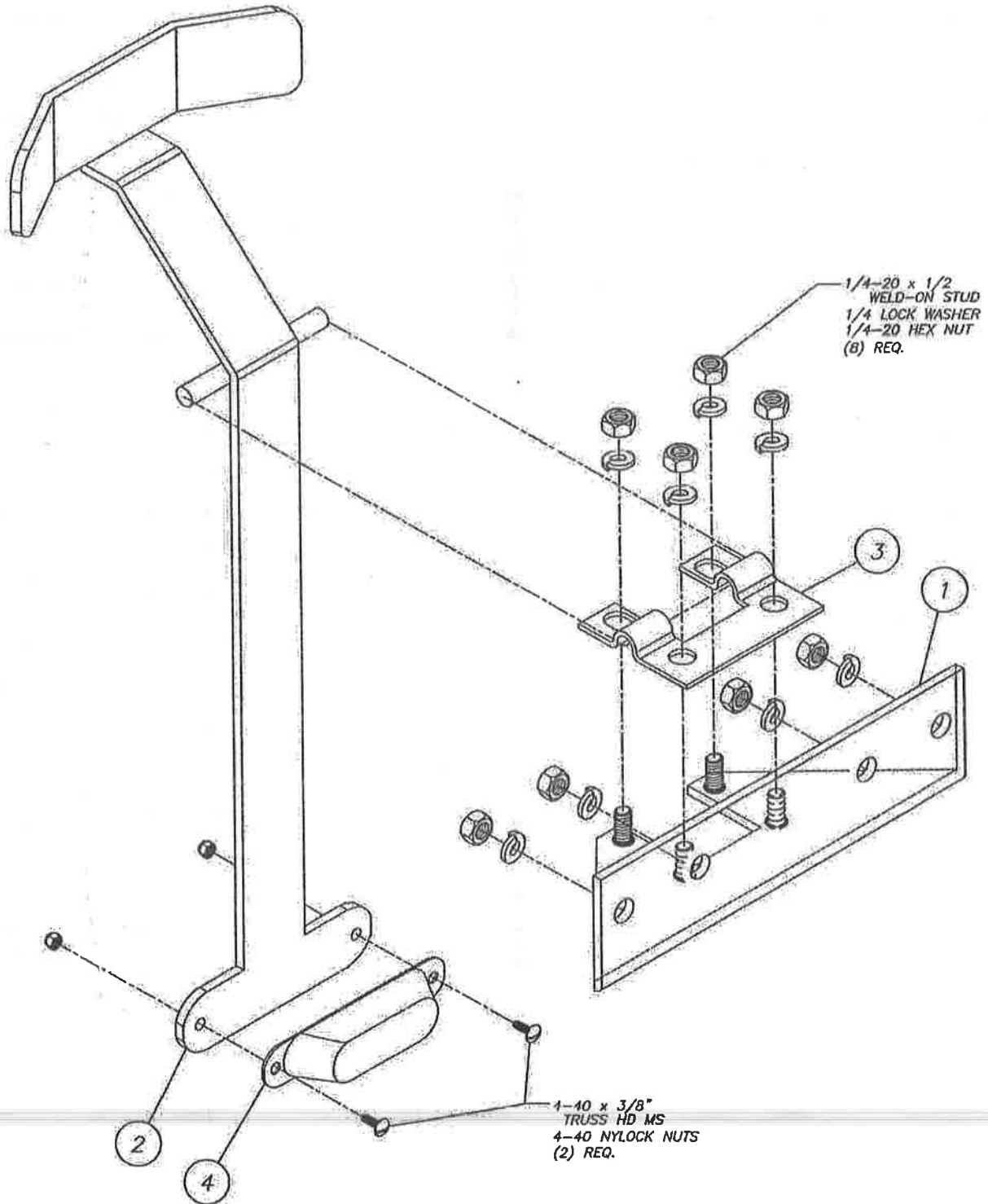

(55B)

RACK SWITCH LEVER ASSEMBLY  
SCT - CONVEYOR

ITEM	DESCRIPTION	REMARKS	REQ.	PART NO.
1	BRACKET, RACK SWITCH TRACK MNTG	3-15-2010 - PRESENT	1	A10 6766
2	LEVER, RACK SWITCH	3-15-2010 - PRESENT	1	A10 6767
3	HINGE STRAP, RACK SWITCH PIVOT	3-15-2010 - PRESENT	1	A10 6768
4	MAGNET, SWITCH		1	A10 4275

\* TO ORDER SUPPLY MACHINE MODEL AND SERIAL NUMBER **(56B)**

# SCRAPPER TANK SPRAY ASSEMBLY OLDER MODELS

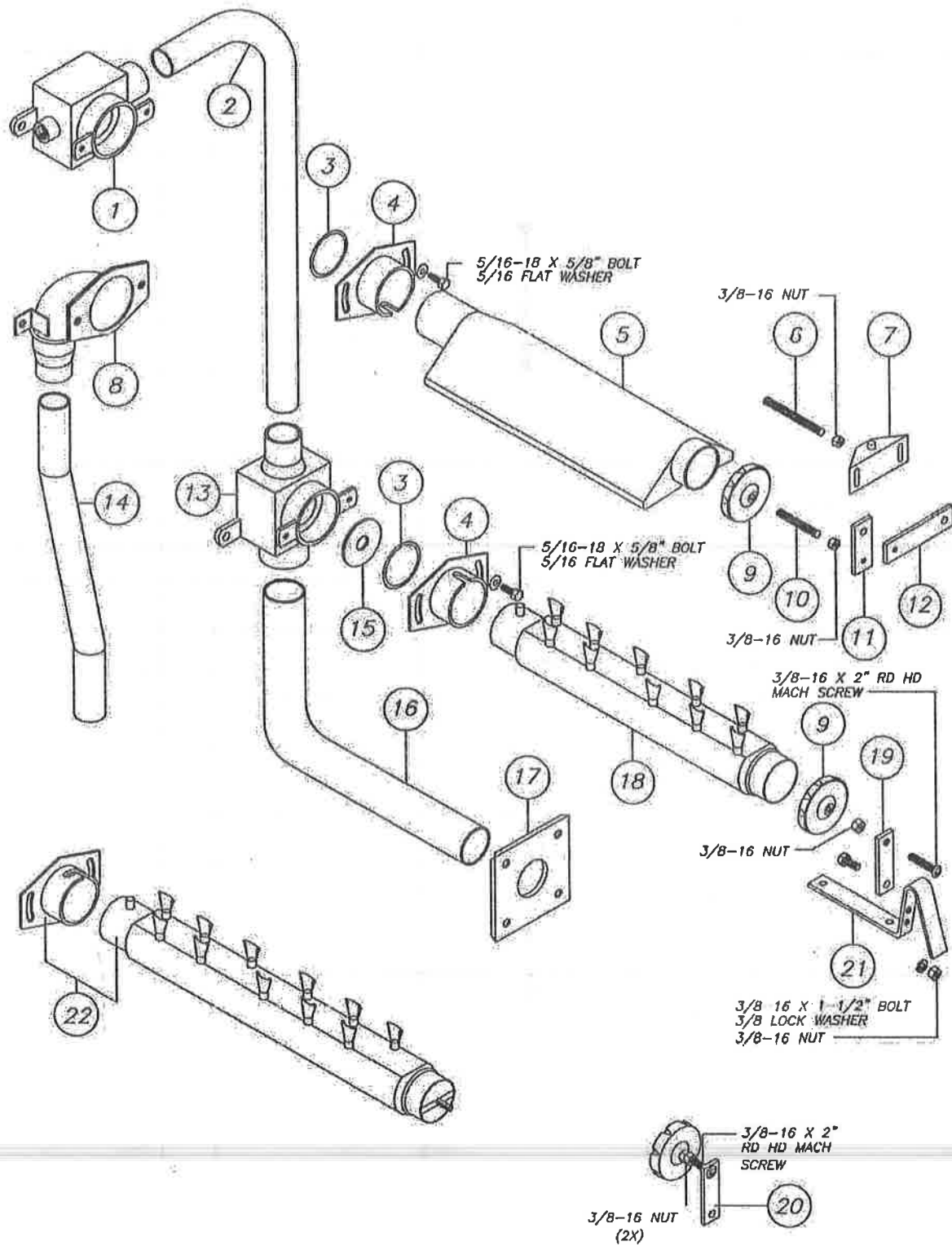

## SCRAPPER TANK SPRAY ASSEMBLY OLDER MODELS

ITEM	DESCRIPTION	REMARKS	REQ.	PART NO.
1	ELBOW UPPER SCRAP MANIFOLD BOX	S# REQ'D		B10-2611
2	STANDPIPE SCRAPPER (SPECIFY IF THE MACHINE HAS A EXTENDED HOOD)			B10-2276
3	O'RING #228 VITON MANIFOLD ADAPTER			P57-2519
4	ADAPTER MANIFOLD ASSM.			B10-2250
5	SPRAY MANIFOLD TOP SCT SCRAPPER	S# REQ'D		C10-1045
6	STUD 3/8-16 X 3-1/4"			A67-2065
7	BRACKET ASSM. UPPER MANIFOLD			A10-3129
8	ELBOW UPPER SCRAP MANIFOLD ASSM.	S# REQ'D		B10-2242
9	SPRAY MANIFOLD END CAP			A10-1868
10	STUD 3/8-16 X 2-1/4"			A67-2388
11	BAR PIVOT UPPER CLAMP			A10-2241
12	PLATE UPPER CLAMP BACKING PLATE			A10-2240
13	BOX ASSM. LOWER MANIFOLD SCRAPPER			B10-2246
14	SCRAPPER RISER TUBE			A10-2275
15	FLOW RESTRICTOR 3/4"			A10-2252
	FLOW RESTRICTOR 1"			A10-2253
	FLOW RESTRICTOR 1-1/8"			A10-2254
	FLOW RESTRICTOR 1-1/4"			A10-2255
	FLOW RESTRICTOR 1-1/2"			A10-2256
16	PIPE CARRY-OVER PUMP TO MANIFOLD SCRAP TANK	S# REQ'D		B10-1991
17	FLANGE CARRY-OVER PIPE			B10-1992
	FLANGE CARRY-OVER PIPE GASKET			A57-1114
18	MANIFOLD ASSM. LOWER SCRAPPER			B10-2258
	10 SPRAYER (MANIFOLD CAN ALSO BE USED AS A UPPER MANIFOLD)			*
				*
19	ARM PIVOT, SPRAY MANIFOLD			A10-1869
20	ASSEMBLY, PIVOT ARM			**
21	BAR SUPPORT SPRAY MANIFOLD CLAMP			B10-1867
22	PICTURE REPRESENTS OLD STYLE TWIST LOCK MANIFOLD & ADAPTER			**
**	CALL FACTORY WITH MODEL & SERIAL NUMBER (800) 762-7600			

\* TO ORDER SUPPLY MACHINE MODEL AND SERIAL NUMBER

(58)

# SCRAPPER TANK SPRAY ASSEMBLY

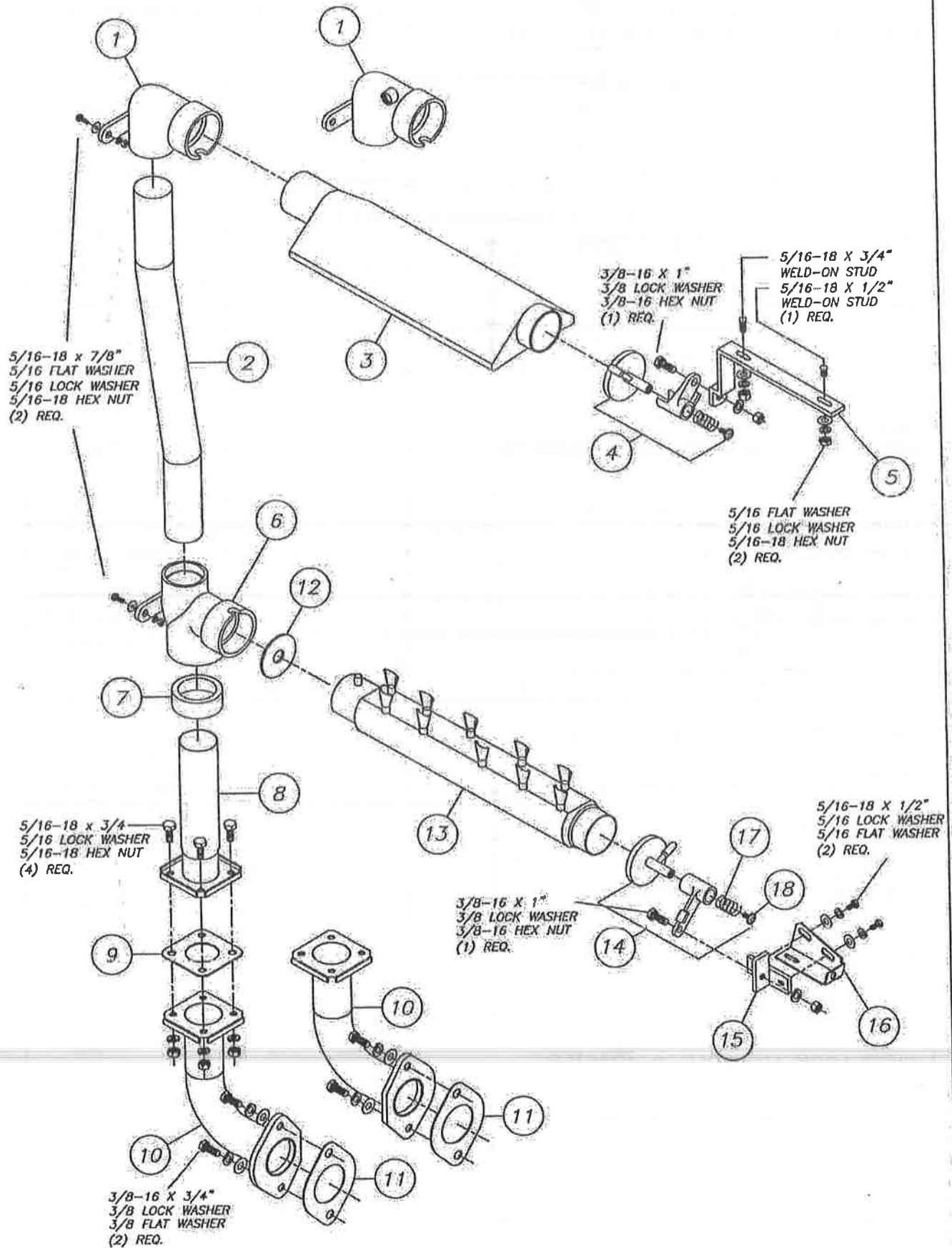



## **SCRAPPER TANK SPRAY ASSEMBLY**

ITEM	DESCRIPTION	REMARKS	REQ.	PART NO.
1	CASTED ELBOW UPPER SCRAP MANIFOLD W/O TEMP. PROBE			B10-2611A
	CASTED ELBOW UPPER SCRAP MANIFOLD WITH TEMP. PROBE			B10-2611B
2	STANDPIPE SCRAPPER (SPECIFY IF THE MACHINE HAS A EXTENDED HOOD)			B10-2276
				P60-1279
3	SPRAY MANIFOLD TOP SCT & SC SCRAPPER	S# REQ'D		C10-1045
4	CASTED UPPER SPRAY MANIFOLD END CAP COMP. ASSEMBLY			B10-6355
5	UPPER SPRAY MANIFOLD SUPPORT BRACKET			A10-6429
6	CASTED TEE LOWER SCRAP MANIFOLD			P44-6451
7	CAST TEE REDUCING COLLAR			A10-6673
8	SCRAPPER MANIFOLD RISER			A10-2270
9	SCRAPPER MANIFOLD RISER GASKET			A57-1114
10	DISCHARGE SCRAPPER PUMP TUBE	LEFT TO RIGHT		B10-1186A
	DISCHARGE SCRAPPER PUMP TUBE	RIGHT TO LEFT		B10-1186B
11	DISCHARGE SCRAPPER PUMP TUBE GASKET			B57-2444
12	FLOW RESTRICTOR 7/8" STANDARD ON 10 SPRAYER MANIFOLDS			
	FLOW RESTRICTOR 1-1/4" STANDARD ON 20 SPRAYER MANIFOLDS			
	FLOW RESTRICTOR 1-1/2" STANDARD ON 28 SPRAYER MANIFOLDS			
13	LOWER 10 SPRAYER MANIFOLD CAN ALSO BE USED AS A UPPER MANIFOLD			B10-2258
14	CASTED LOWER SPRAY MANIFOLD END CAP COMP. ASSEMBLY			B10-6356
15	MANIFOLD END CAP SUPPORT BRACKET			A10-6706
16	MANIFOLD END CAP SUPPORT BRACKET MOUNTING BRACKET			A10-6707
17	MANIFOLD END CAP SPRING USED ON BOTH END CAPS			P60-6654
18	MANIFOLD END CAP FLANGE BUTTON ST.ST. SCREW 5/16-18 x 1/2"			

# WASH/RINSE SPRAY ASSEMBLY

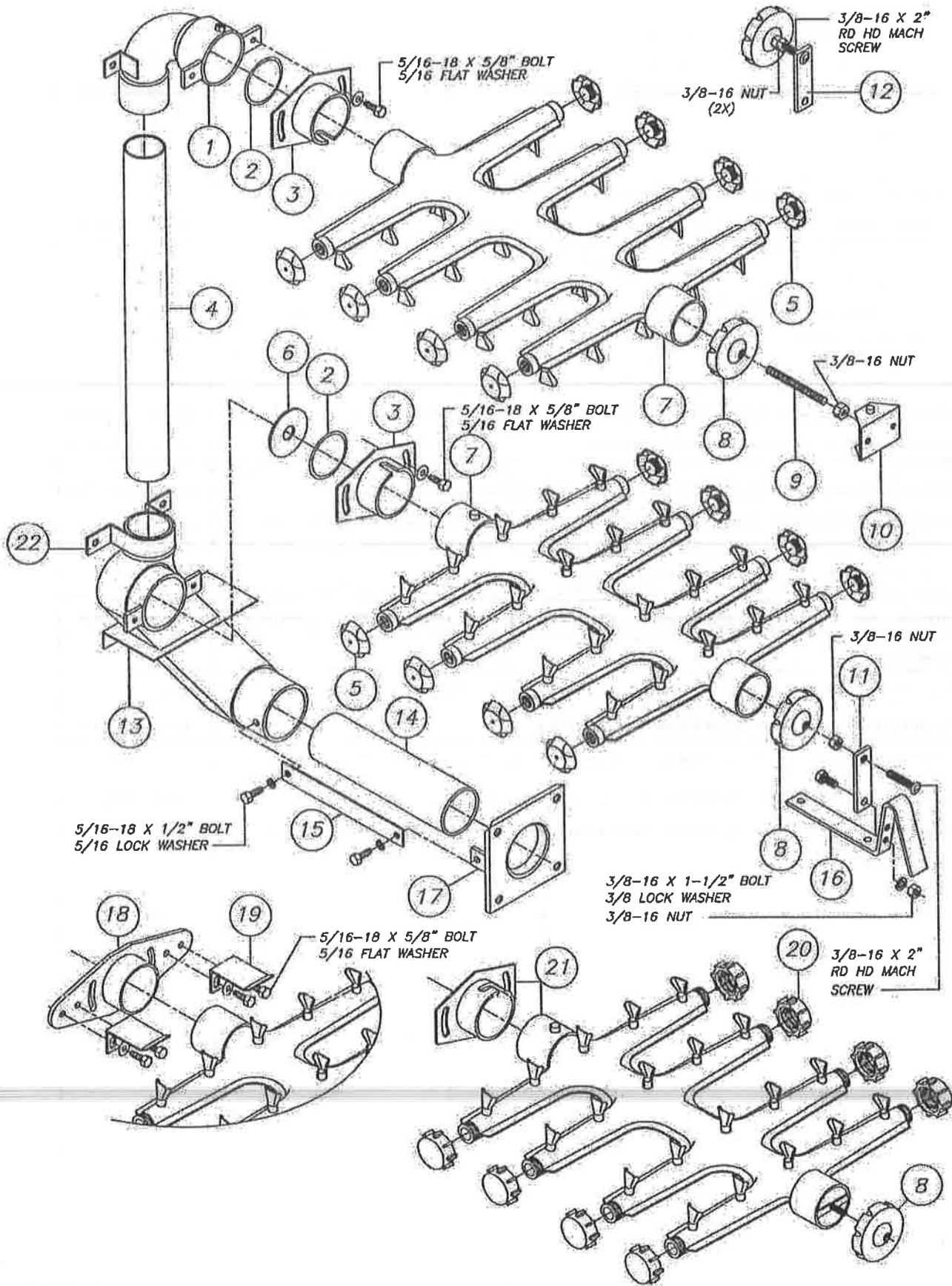

## WASH/RINSE SPRAY ASSEMBLY

ITEM	DESCRIPTION	REMARKS	REQ.	PART NO.
1	ELBOW MANIFOLD UPPER			B10-1995
2	O-RING #228 VITON			P57-2519
3	ADAPTER MANIFOLD	S# REQ'D		B10-2250
4	STANDPIPE (SPECIFY IF THE MACHINE HAS A EXTENDED HOOD)			A10-1994
5	CAP, CLEAN OUT TREE STYLE MANIFOLD	(MALE)		A10-3318
6	RESTRICTOR FLOW 3/4"			A10-2252
	RESTRICTOR FLOW 1"			A10-2253
	RESTRICTOR FLOW 1-1/8"			A10-2254
	RESTRICTOR FLOW 1-1/4"			A10-2255
	RESTRICTOR FLOW 1-1/2"			A10-2256
7	MANIFOLD CENTER FED (28 SPRAYERS)			C10-1259
	MANIFOLD CENTER FED (20 SPRAYERS)			C10-1162
	MANIFOLD CENTER FED (20 SPRAYERS)- (WITH EXTENDED COLLAR)			C10-1257
8	END CAP SPRAY MANIFOLD			A10-1868
9	STUD 3/8-16 X 3-1/4"			A67-2065
10	BRACKET ASSM. UPPER MANIFOLD END CAP			A10-3129
11	ARM PIVOT SPRAY MANIFOLD			A10-1869
12	ASSEMBLY, PIVOT ARM			**
13	TEE & ELBOW COMBINATION S.S.			C10-1087
14	TUBE CROSS OVER 8-11/16" LONG			B10-1865
15	RETAINER FEED PIPE FLANGE TEE			A10-1993
16	BAR SUPPORT SPRAY MANIFOLD CLAMP			B10-1867
17	FLANGE DISCHARGE 368 PUMP			B10-1860
THE BELOW PARTS REPRESENT OLD STYLE MANIFOLDS				
18	FLANGE MANIFOLD ADJUSTMENT			A10-1988
19	BRACKET MANIFOLD ORIENT	NLA		A10-1990
20	CAP, CLEAN OUT TREE STYLE MANIFOLD RED PLASTIC (REPLACES OLD STYLE S.S. CAP #A10-2028)	(FEMALE)		A59-2227
21	PICTURE REPRESENTS OLD STYLE TWIST LOCK MANIFOLD & ADAPTER			**
22	"U" BRACKET			A10-2007

\*\* CALL FACTORY WITH MODEL & SERIAL NUMBERS (800) 762-7600 (60)

# WASH/RINSE SPRAY ASSEMBLY

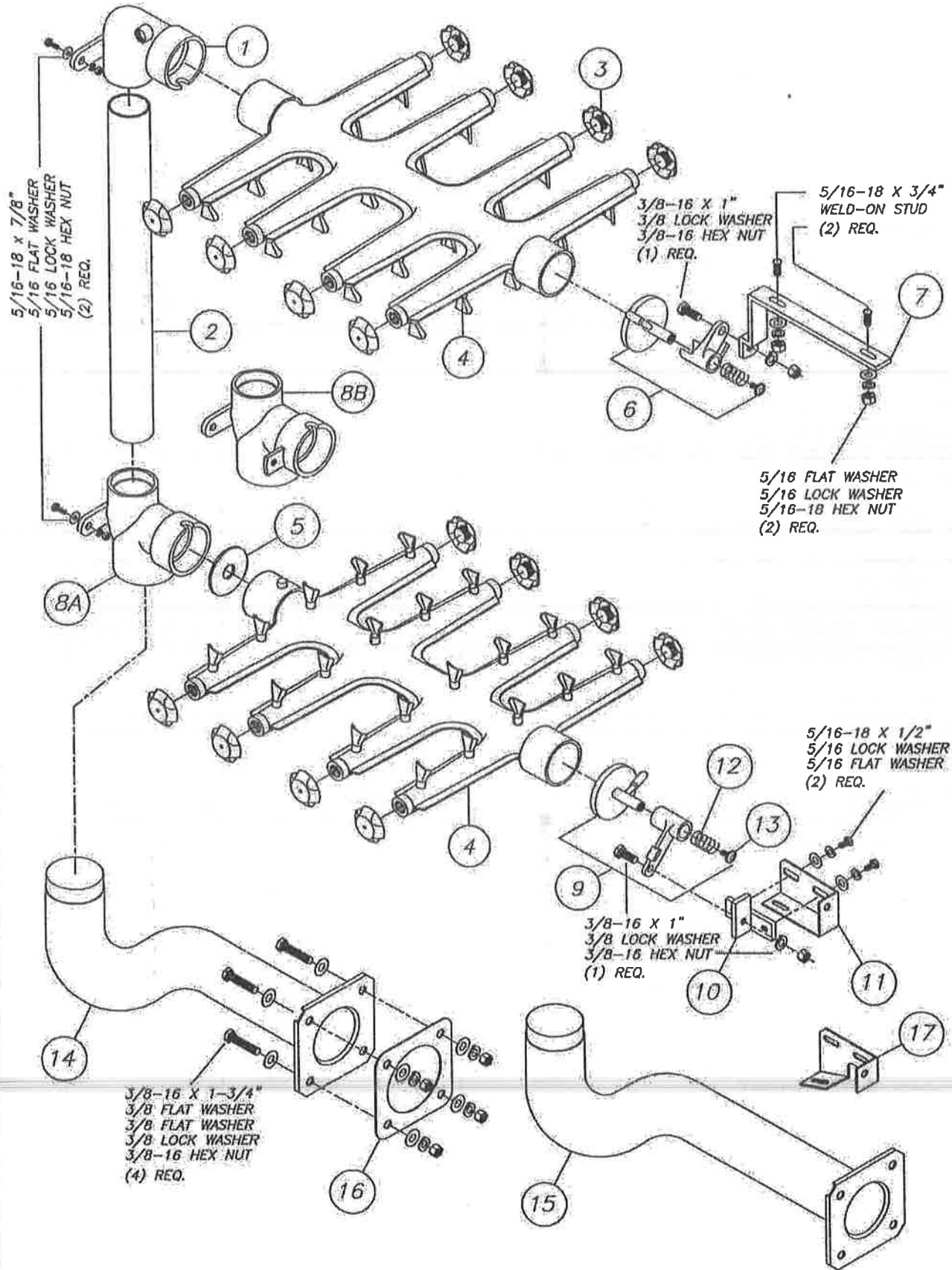

(59B)

## WASH/RINSE SPRAY ASSEMBLY

ITEM	DESCRIPTION	REMARKS	PART NO.
1	CASTED ELBOW UPPER MANIFOLD WITH TEMP. PROBE		P44-6452
2	STANDPIPE (SPECIFY IF THE MACHINE HAS A 3" OR 8" EXTENDED HOOD)		A10-1994
3	CAP, CLEAN OUT TREE STYLE MANIFOLD		A10-3318
4	MANIFOLD CENTER FED (28 SPRAYERS)	(MALE)	C10-1259
	MANIFOLD CENTER FED (20 SPRAYERS)		C10-1162
	MANIFOLD CENTER FED (20 SPRAYERS)- (WITH EXTENDED COLLAR)		C10-1257
5	RESTRICTOR FLOW 3/4" STANDARD ON 10 SPRAYER MANIFOLDS		
	RESTRICTOR FLOW 1" STANDARD ON 18 SPRAYER MANIFOLDS		
	RESTRICTOR FLOW 1-1/8"		
	RESTRICTOR FLOW 1-1/4" STANDARD ON 20 SPRAYER MANIFOLDS		
	RESTRICTOR FLOW 1-1/2" STANDARD ON 28 SPRAYER MANIFOLDS		
6	CASTED UPPER SPRAY MANIFOLD END CAP COMP. ASSEMBLY		B10-6355
7	UPPER SPRAY MANIFOLD END CAP SUPPORT BRACKET		A10-6429
8	CASTED TEE FOR LOWER MANIFOLD		P44-6451A
	CASTED TEE FOR MODULAR SC 1 2 & 3 SECTIONS		P44-6451B
9	CASTED LOWER SPRAY MANIFOLD END CAP COMP. ASSEMBLY		B10-6356
10	MANIFOLD END CAP SUPPORT BRACKET		A10-6706
11	MANIFOLD END CAP SUPPORT BRACKET SCT & SC		A10-6457
12	MANIFOLD END CAP SPRING USED ON BOTH END CAPS		P60-6654
13	MANIFOLD END CAP FLANGE BUTTON ST.ST. SCREW 5/16-18 X 1/2"		
14	DISCHARGE PUMP TUBE FOR WASH, RINSE, SCRAPER TANKS		A10-6566
15	DISCHARGE PUMP TUBE FOR MODULAR SC 1, 2, & 3 SECTIONS		A10-6682
16	DISCHARGE PUMP FLANGE GASKET		B57-1757
17	MANIFOLD END CAP SUPPORT BRACKET ER MACHINES ONLY		A10-6707

\* TO ORDER SUPPLY MACHINE MODEL AND SERIAL NUMBER

# FINAL RINSE HIGH TEMP ASSEMBLY

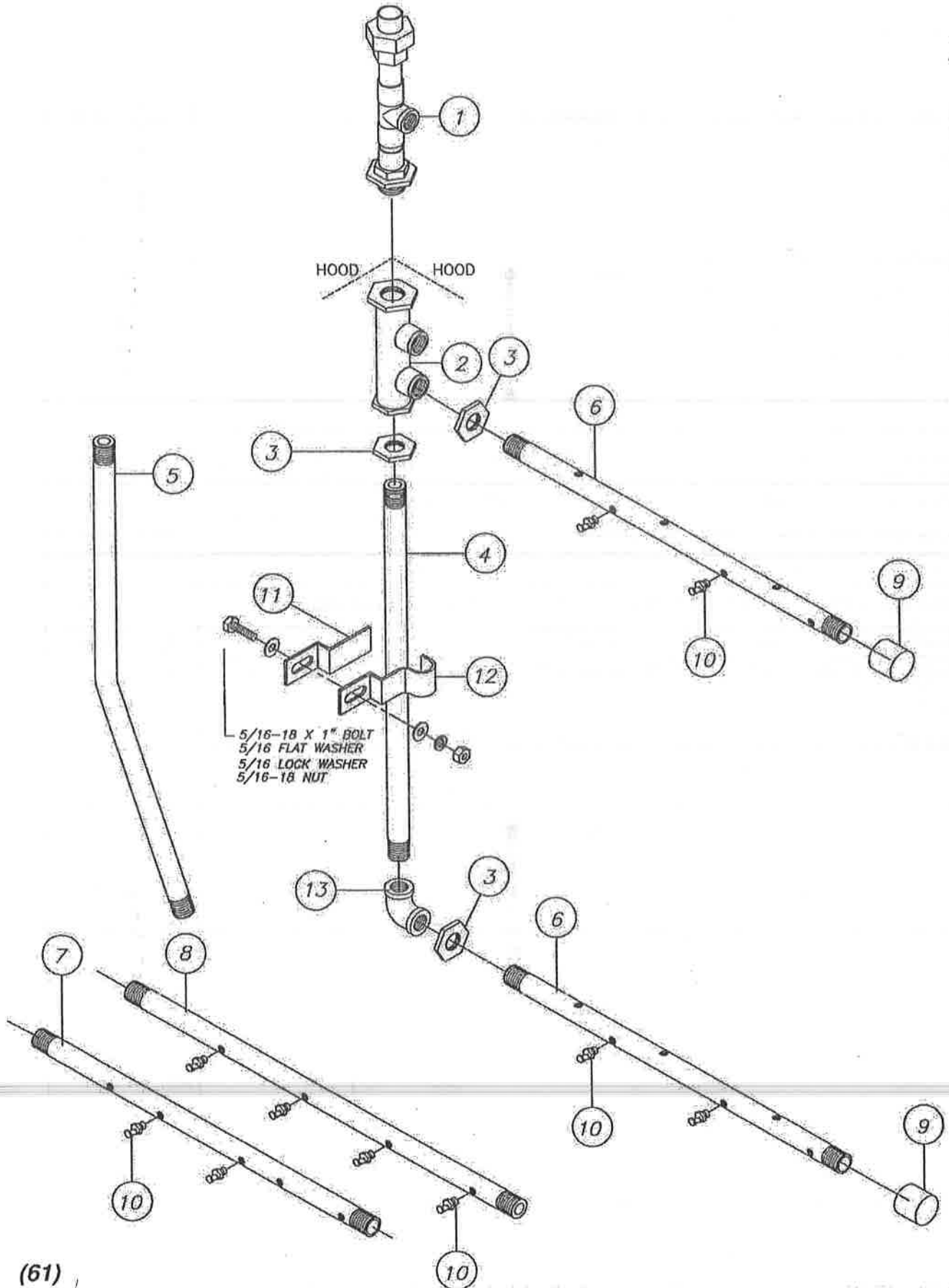

## FINAL RINSE HIGH TEMP ASSEMBLY

ITEM	DESCRIPTION	REMARKS	REQ.	PART NO.
1	TOWER FINAL RINSE HI TEMP COPPER			A10-4564
2	TEE UPPER FINAL RINSE S.S.	A10-1301		A10-4547
3	LOCKNUT S.S. 1/2" NPT			A10-1446
4	RISER PIPE FINAL RINSE 20-1/4" LONG S.S. (SPECIFY IF THE MACHINE HAS A EXTENDED HOOD)			A10-1279
5	ANGLED RISER PIPE FINAL RINSE USED ON SC-4 SECTION S.S.(SPECIFY IF THE MACHINE HAS A EXTENDED HOOD)			*
6	PIPE, FINAL RINSE,UPPER & LOWER 18-1/2" LONG 6 HOLES S.S.			B10-1172
7	PIPE, FINAL RINSE,UPPER & LOWER 18-1/2" LONG 5 HOLES INLINE S.S.			A10-6114
8	PIPE, FINAL RINSE,UPPER & LOWER 18-1/2" LONG 4 HOLES INLINE S.S.			B10-2680
9	CAP CPVC 1/2" FIP			P68-1293
10	JET S.S. FINAL RINSE (USED ON MACHINES W/O A POWER RINSE)	.073 ORIFICE		B50-3297
	(USED ON MACHINES WITH A POWER RINSE)	.063 ORIFICE		B50-1173
11	BRACKET RISER PIPE S.S.			A10-3721
12	CLAMP RISER PIPE S.S.			A10-3722
13	ELBOW 90° 1/2" BRASS FIP	P68-1478		P68-1887

# FINAL RINSE LOW TEMP ASSEMBLY

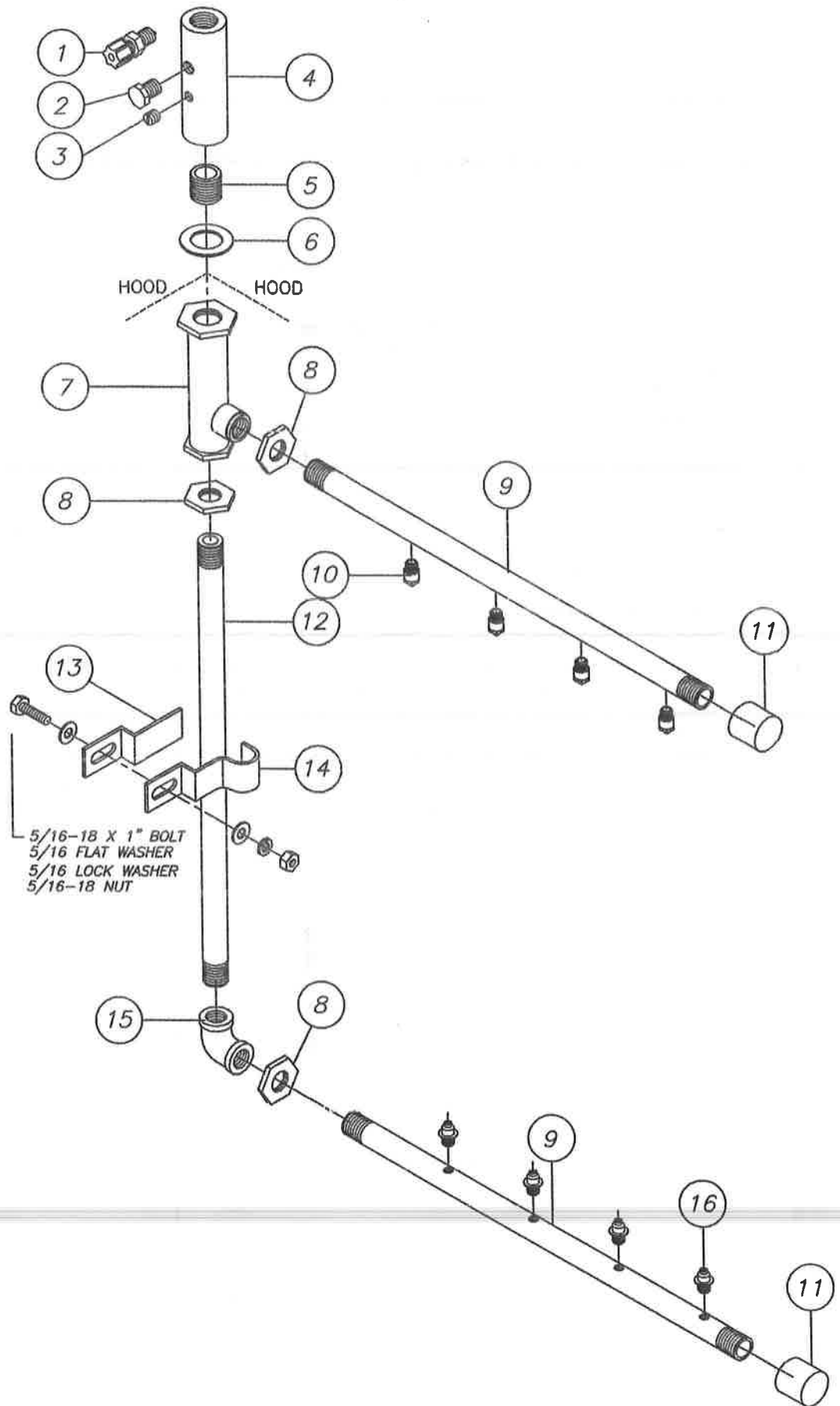



## FINAL RINSE LOW TEMP ASSEMBLY

ITEM	DESCRIPTION	REMARKS	REQ.	PART NO.
1	DUCK BILL CHECK VALVE PLASTIC			P68-1982
2	PLUG 1/2" MIP CPVC			P68-2676
3	PLUG 1/8-27 SLOTTED S.S.			A50-2435
4	CHEMICAL MIXING TOWER S.S.			P68-5278
5	3/4 X 1" S.S. NIPPLE STRAIGHT			A10-5779
6	GASKET TOWER			A10-1909
7	TEE UPPER FINAL RINSE S.S.			A10-4547
8	LOCKNUT S.S. 1/2" NPT			A10-1446
9	PIPE, FINAL RINSE, UPPER & LOWER 18-1/2" LONG 4 HOLES INLINE S.S.			B10-2679A
10	SPRAYER, FINAL RINSE, S.S. (SQUARE)	NOTE:5/98		A10-6111
11	CAP CPVC 1/2" FIP			P68-1293
12	RISER PIPE FINAL RINSE 20-1/4" LONG S.S. (SPECIFY IF THE MACHINE HAS A EXTENDED HOOD)			A10-1279
13	BRACKET RISER PIPE S.S.			A10-3721
14	CLAMP RISER PIPE S.S.			A10-3722
15	ELBOW 90° 1/2" BRASS FIP			P68-1478
16	SPRAYER, FINAL RINSE, PLASTIC(ROUND)	NOTE:5/98		A10-6112

\* TO ORDER SUPPLY MACHINE MODEL AND SERIAL NUMBER

# FINAL RINSE HIGH TEMP ASSEMBLY

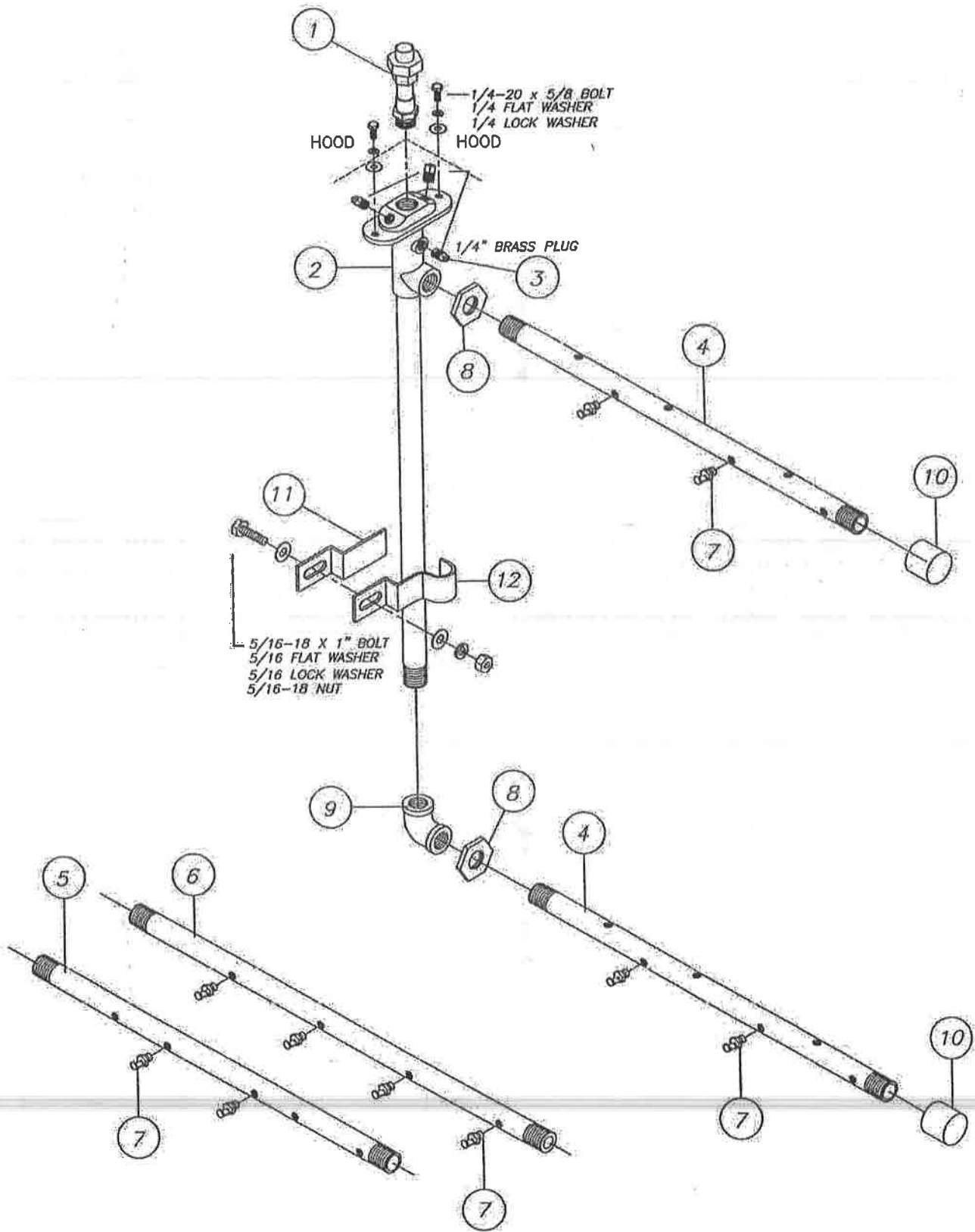

### FINAL RINSE HIGH TEMP ASSEMBLY

ITEM	DESCRIPTION	REMARKS	REQ.	PART NO.
1	NEED NAME & PART NUMBER			*
2	CASTED FINAL RINSE TEE W/ RISER PIPE	STD. 21-1/8"		A10-6755
	CASTED FINAL RINSE TEE W/ RISER PIPE	STD. + 3"		A10-6756
	CASTED FINAL RINSE TEE W/ RISER PIPE	STD. + 6"		A10-6757
3	1/4" BRASS PLUG			P68-1489
4	PIPE, FINAL RINSE, UPPER & LOWER 18-1/2" LONG 6 HOLES S.S.			B10-1172
5	PIPE, FINAL RINSE, UPPER & LOWER 18-1/2" LONG 5 HOLES INLINE S.S.			A10-6114
6	PIPE, FINAL RINSE, UPPER & LOWER 18-1/2" LONG 4 HOLES INLINE S.S. 18-1/2" LONG 4 HOLES INLINE S.S.			B10-2680
7	JET S.S. FINAL RINSE (USED ON MACHINES W/O A POWER RINSE) (USED ON MACHINES WITH A POWER RINSE)	.073 ORIFICE .063 ORIFICE		B50-3297 B50-1173
8	LOCKNUT S.S. 1/2" NPT			A10-1446
9	ELBOW 90° 1/2" BRASS FIP			P68-1478
10	CAP CPVC 1/2" FIP			P68-1293
11	BRACKET RISER PIPE S.S.			A10-3721
12	CLAMP RISER PIPE S.S.			A10-3722

\* TO ORDER SUPPLY MACHINE MODEL AND SERIAL NUMBER

# OLD STYLE LOW TEMP RINSE ASSM.

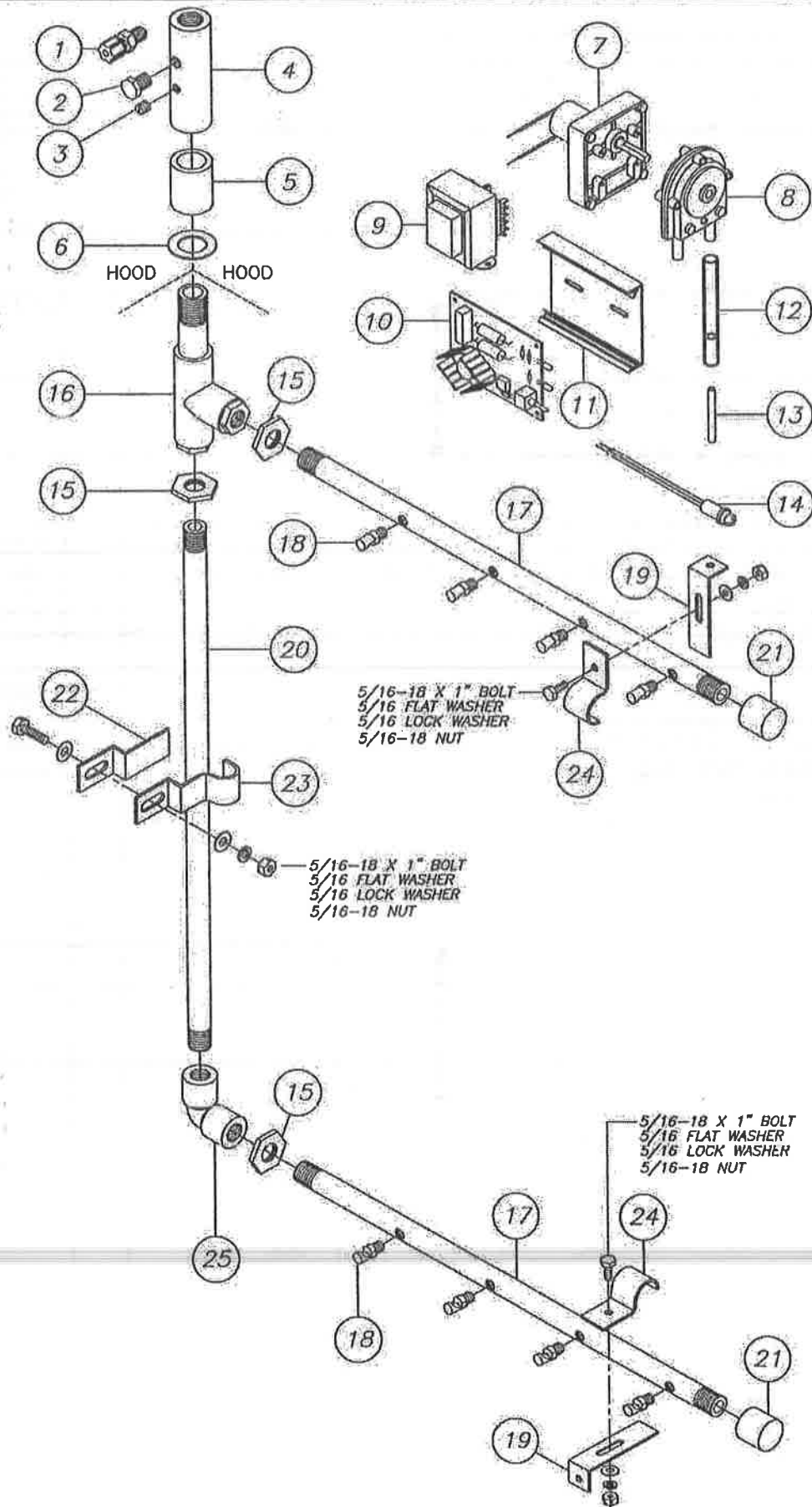

## OLD STYLE LOW TEMP RINSE ASSM.

ITEM	DESCRIPTION	REMARKS	REQ.	PART NO.
1	DUCK BILL CHECK VALVE PLASTIC			P68-1982
2	PLUG 1/4" MIP CPVC			P68-1298
3	PLUG 1/8-27 SLOTTED SS			A50-2435
4	CHEMICAL MIXING TOWER SS			P68-5278
5	SLEEVE RINSE TEE CPVC			A10-3288
6	GASKET TOWER			A10-1909
7	PUMP MOTOR DC			P41-1011
8	CHEMICAL PUMP COMPLETE			P41-1001
	SQUEEZE TUBE (INCLUDED WITH PUMP)			P68-1005
9	TRANSFORMER DC POWER SUPPLY			P53-1054
10	PC BOARD DC POWER SUPPLY			P42-1864
11	SNAP TRACK 4" LONG			P42-1049
12	SIGHT TUBE ASSM.			A10-1340C
13	CHEMICAL TUBE 1/4" RED	DETERGENT		P68-1021
	CHEMICAL TUBE 1/4" WHITE	SANITIZER		P68-1022
	CHEMICAL TUBE 1/4" BLUE	RINSE AID		P68-1023
14	LAMP PILOT LIGHT RED 14 V.			P49-1721
15	LOCKNUT SS 1/2" NPT			A10-1446
16	TEE ASSM. FINAL RINSE CPVC			A10-1913
17	PIPE UPPER & LOWER FINAL RINSE CPVC (LARGE JETS RECOMMENDED)	CSA TYPE		B10-2679
	PIPE UPPER & LOWER FINAL RINSE CPVC (SMALL JETS RECOMMENDED)	CS TYPE		B10-1906
	PIPE UPPER & LOWER FINAL RINSE CPVC (SMALL JETS RECOMMENDED)	SC-9 TYPE		B10-2224
18	SPRAY JET CPVC .063 HOLE	CS TYPE		B10-1870
	SPRAY JET CPVC .073 HOLE	CSA TYPE		B10-2318
19	BRACKET SPRAY PIPE SS			A10-3670
20	RISER PIPE FINAL RINSE 19-3/4" LONG CPVC (SPECIFY IF THE MACHINE HAS A EXTENDED HOOD)			B10-1907
21	CAP CPVC 1/2" FIP			P68-1293
22	BRACKET RISER PIPE SS			A10-3721
23	CLAMP RISER PIPE BRACKET SS			A10-3722
24	CLAMP PIPE BRACKET SS			A10-2021
25	ELBOW CPVC 90° 1/2" FIP			P68-1294

\* TO ORDER SUPPLY MACHINE MODEL AND SERIAL NUMBER

(68)

# NEW STYLE LO TEMP RINSE ASSM.

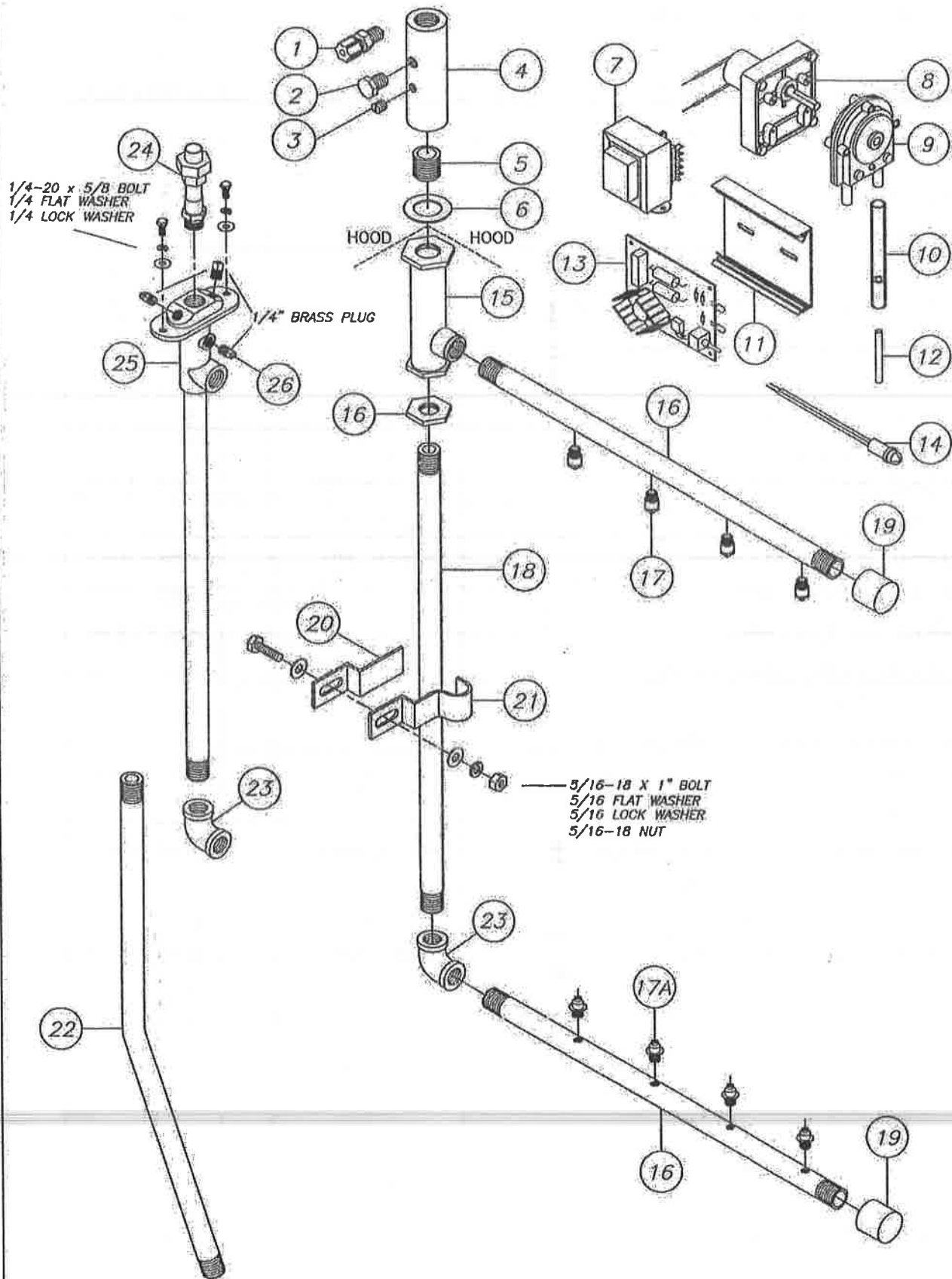

## NEW STYLE LO TEMP RINSE ASSM.

ITEM	DESCRIPTION	REMARKS	REQ.	PART NO.
1	DUCK BILL CHECK VALVE PLASTIC			P68-1982
2	PLUG 1/4" MIP CPVC			P68-1298
3	PLUG 1/8-27 SLOTTED SS			A50-2435
4	CHEMICAL MIXING TOWER SS			P68-5278
5	3/4 X 1" SS NIPPLE STRAIGHT			A10-5779
6	GASKET TOWER			A10-1909
7	TRANSFORMER DC POWER SUPPLY			P53-1054
8	PUMP MOTOR DC			P41-1011
9	CHEMICAL PUMP COMPLETE			P41-1001
	SQUEEZE TUBE (INCLUDED WITH PUMP)			P68-1005
10	SIGHT TUBE ASSM.			A10-1340
11	SNAP TRACK 4" LONG			P42-1049
12	CHEMICAL TUBE 1/4" RED			P68-1021
	CHEMICAL TUBE 1/4" WHITE			P68-1022
	CHEMICAL TUBE 1/4" BLUE			P68-1023
13	PC BOARD DC POWER SUPPLY			P42-1864
14	LAMP PILOT LIGHT RED 14 V.			P49-1721
15	TEE UPPER FINAL RINSE SS			A10-4547
16	UPPER & LOWER S/S FINAL RINSE PIPES WITH 4 HOLES USED ON SINGLE OR MULTIPLE LOW TEMP. MACHINES.			B10-2679A
17	UPPER FINAL RINSE S/S SPRAYERS 1/8 X 27 SQUARE			A10-6111
17A	LOWER FINAL RINSE SPRAYERS 1/8 X 27 .073 PLASTIC ROUND			A10-6112
18	RISER PIPE FINAL RINSE 20-1/4" LONG SS (SPECIFY IF THE MACHINE HAS A EXTENDED 3" OR 6" HOOD)			A10-1279 *
19	CAP CPVC 1/2" FIP			P68-1293
20	BRACKET RISER PIPE SS			A10-3721
21	CLAMP RISER PIPE BRACKET SS			A10-3722
22	ANGLED RISER PIPE FINAL RINSE USED ON SC-4 SECTIONS SS (SPECIFY IF THE MACHINE HAS A EXTENDED 3" OR 6" HOOD)			A10-1279 *
23	ELBOW 90° 1/2" S/S FIP			P68-1887
24	NEED NAME AND PART NUMBER			
25	NEW STYLE CASTED FINAL RINSE TEE (SPECIFY IF THE MACHINE HAS A EXTENDED 3" OR 6" HOOD)			A10-6521 *
26	1/4" BRASS PLUG			P68-1489

\* TO ORDER SUPPLY MACHINE MODEL AND SERIAL NUMBER

(70)

# ECO-LAB FINAL RINSE ASSEMBLY

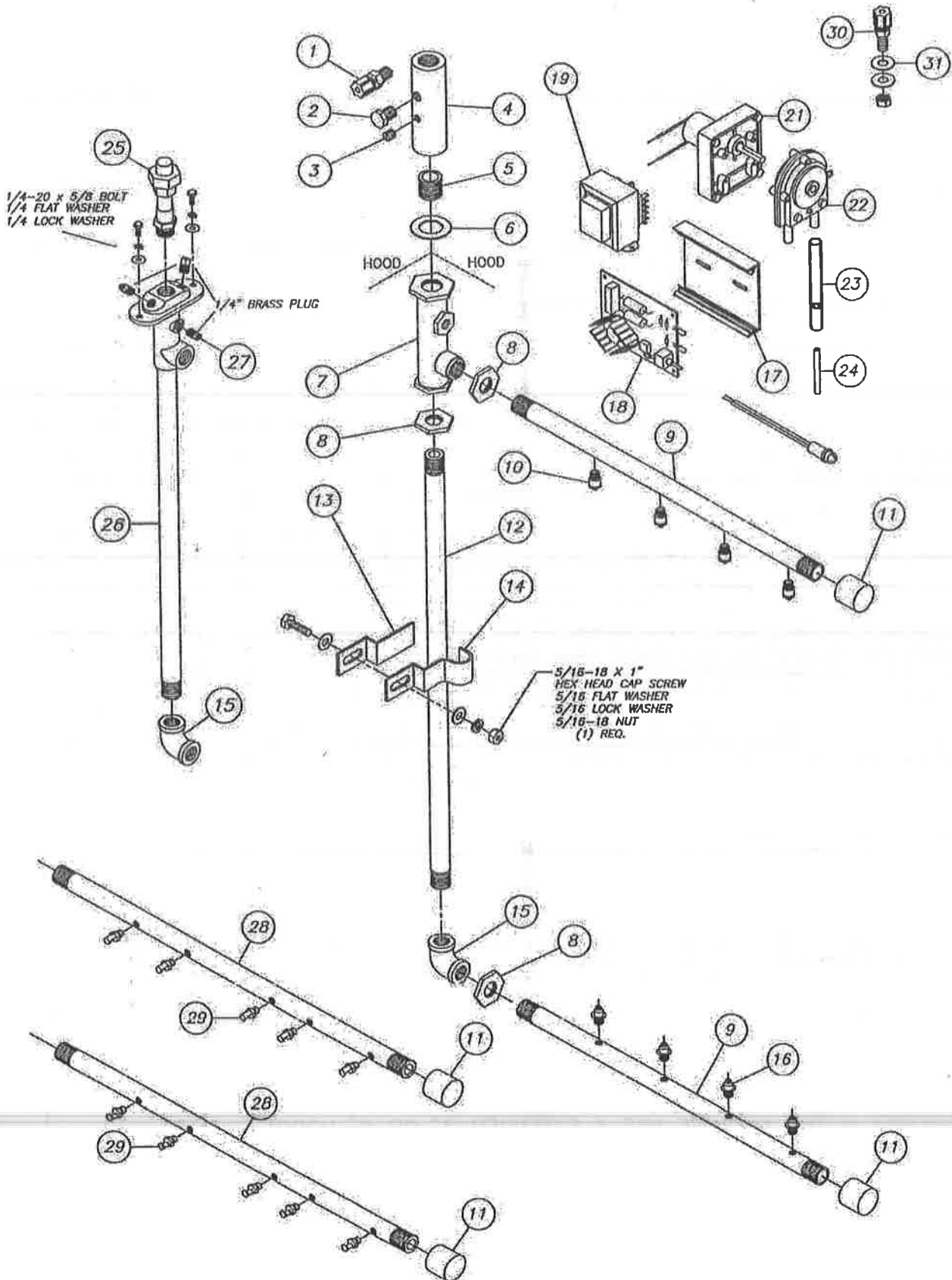



## ECO-LAB FINAL RINSE ASSEMBLY

ITEM	DESCRIPTION	REMARKS	REQ.	PART NO.
1	DUCK BILL CHECK VALVE PLASTIC			P68-1982
2	PLUG 1/4" MIP CPVC PLASTIC			P68-1298
3	PLUG 1/8" X 27 SLOTTED S/S			A50-2435
4	CHEMICAL MIXING TOWER S/S			P68-5278
5	3/4" X 1" S/S NIPPLE STRAIGHT			A10-5779
6	GASKET TOWER			A10-1909
7	TEE UPPER FINAL RINSE S/S			A10-4547
8	LOCKNUT S/S 1/2" NPT			A10-1446
9	UPPER & LOWER S/S FINAL RINSE PIPES WITH 4 HOLES			B10-2679A
10	FINAL RINSE S/S SPRAYER 1/8 X 27 .073 SQUARE			A50-6111
11	CAP CPVC 1/2" FIP			P68-1293
12	RISER PIPE FINAL RINSE 20-1/4" LONG S/S			A10-1279
13	RISER BRACKET PIPE S/S			A10-3721
14	RISER PIPE CLAMP BRACKET S/S			A10-3722
15	ELBOW 90 1/2" BRASS FIP			P68-1478
16	FINAL RINSE PLASTIC SPRAYER 1/8 X 27 .073 ROUND			A50-6112
17	SNAP TRACK 4" LONG			P42-1049
18	CHLORINE DISPENSING PC CONTROL BOARD			P42-1864
19	TRANSFORMER DC POWER SUPPLY			P53-1054
20	CHLORINE DISPENSING PILOT LIGHT RED 14V.			P49-1721
21	CHLORINE DISPENSING DC PUMP MOTOR			P41-1011
22	CHLORINE DISPENSING PUMP COMPLETE WITH SQUEEZE TUBE			P41-1001
23	SQUEEZE TUBE			P68-1005
24	CHEMICAL TUBING 1/4" WHITE			P68-1022
25	NEED NAME AND PART NUMBER			
26	CASTED FINAL RINSE TEE W/ RISER PIPE	STD. 21-1/8"		A10-6755
	CASTED FINAL RINSE TEE W/ RISER PIPE	STD. + 3"		A10-6756
	CASTED FINAL RINSE TEE W/ RISER PIPE	STD. + 6"		A10-6757
27	1/4" BRASS PLUG			P68-1489
28	FINAL RINSE PIPE UPPER AND LOWER S/S 18-1/2" LONG WITH 5 HOLES			A10-5745
29	FINAL RINSE S/S SPRAYER WITH .073 ORIFICE USED ON MACHINE WITHOUT A POWER RINSE.			B50-3297
	FINAL RINSE S/S SPRAYER WITH .063 ORIFICE USED ON MACHINE WITH A POWER RINSE.			B50-1173
30	BULK HEAD FITTING PLASTIC			P68-1019
31	STAINLESS STEEL WASHER			A10-2024

\* TO ORDER SUPPLY MACHINE MODEL AND SERIAL NUMBER

( 72 )

# ER RINSE AND FINAL RINSE ASSEMBLY

1/4-20 x 5/8 BOLT  
1/4 FLAT WASHER  
1/4 LOCK WASHER

1/4-20 x 5/8 BOLT  
1/4 FLAT WASHER  
1/4 LOCK WASHER  
1/4-20 HEX NUT

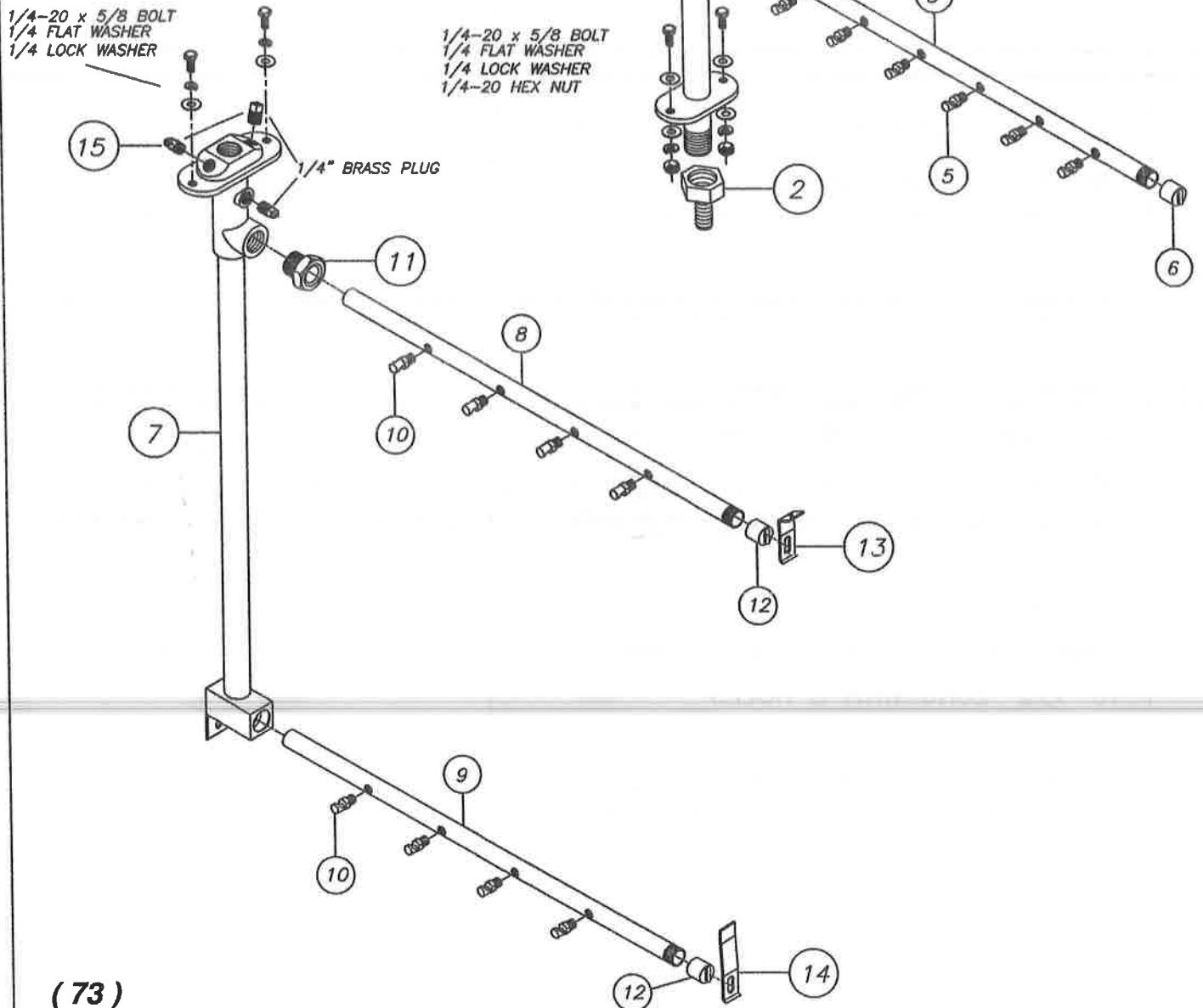

# ER RINSE AND FINAL RINSE ASSEMBLY

ITEM	DESCRIPTION	REMARKS	REQ.	PART NO.
1	ASSY STANDPIPE ER STANDARD		1	A10-6442
	ASSY STAND PIPE ER + 3		1	A10-6718
2	1/2" HOSE BARB		1	P68-6514
3	PIPE ER BTM 1/2" AUX. RINSE 6 HOLE	20-5/8"	1	A10-6371
4	PIPE ER TOP 1/2" AUX. RINSE 4 HOLE	20-5/8"	1	A10-6370
5	SPRAY NOZZLES .086 SS FAN TYPE		10	B50-1382
6	CAP ER PIPE 1/2"		2	A10-6396
7	ASSY STAND PIPE FINAL RINSE ER	*	1	A10-6448
	ASSY STAND PIPE FINAL RINSE ER + 3	*	1	A10-6720
8	PIPE FINAL RINSE ER TOP 3/8" 4 HOLE	20"	1	A10-6446
9	PIPE FINAL RINSE ER BTM 3/8" 4 HOLE	20-1/2"	1	A10-6372
10	SPRAY NOZZLES .052 SS FAN TYPE	*	8	A10-6373
11	FINAL RINSE ADAPTOR ER	*	*	A10-6721
12	CAP FINAL RINSE ER 3/8"	*	2	A10-6397
13	SPRING SPRAYER RETAINER "TOP"	*	*	A10-6709
14	SPRING SPRAYER RETAINER "BTM"	*	*	A10-6708
15	1/4" BRASS PLUG	*	*	P68-1489
	#7 USED ONLY WITH AUXILIARY RINSE MACHINES			
	ER-44, ER66S, ER76S			

\* TO ORDER SUPPLY MACHINE MODEL AND SERIAL NUMBER

# CS POWER RINSE ASSEMBLY

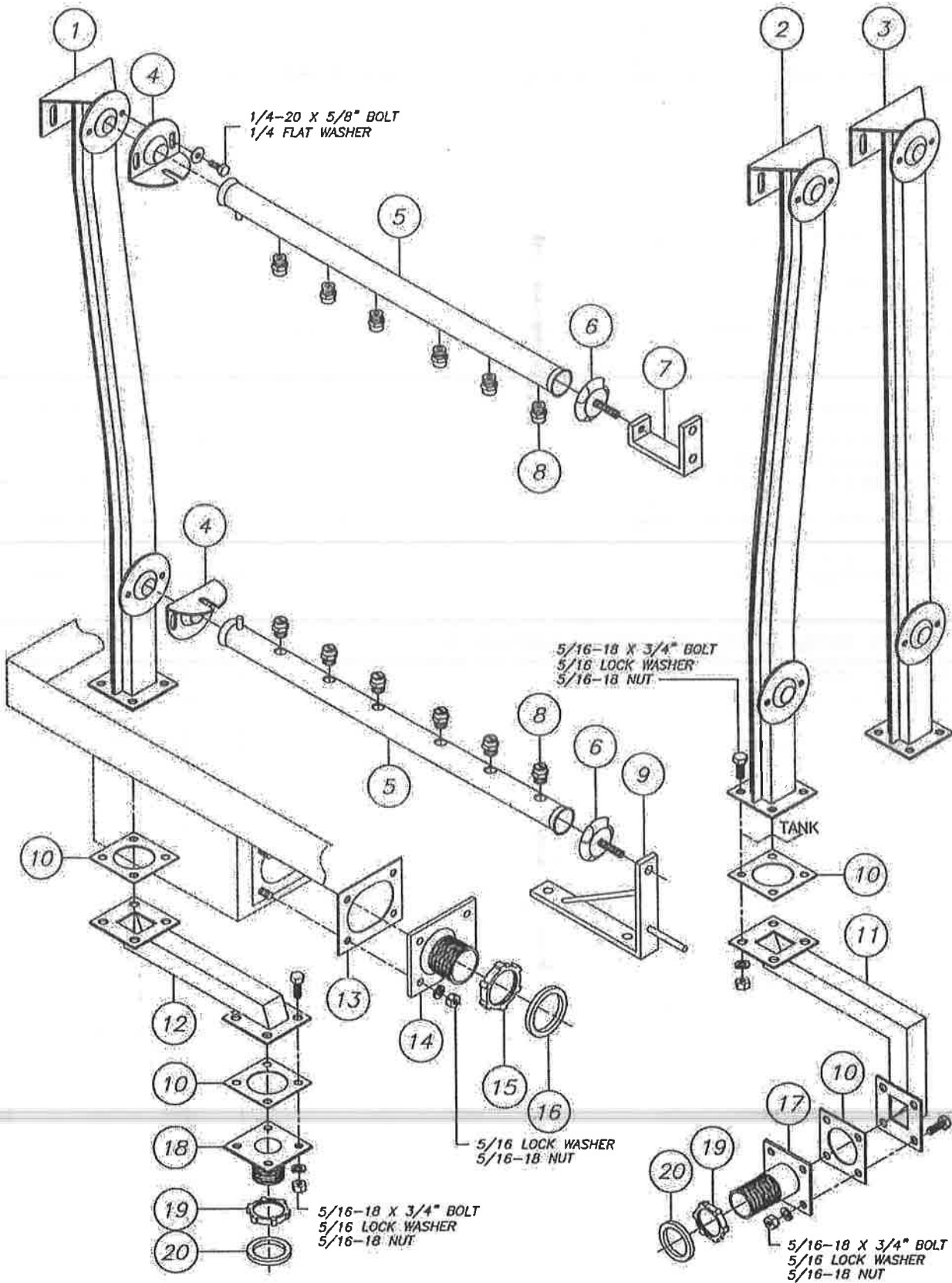

## CS POWER RINSE ASSEMBLY

ITEM	DESCRIPTION	REMARKS	REQ.	PART NO.
1	RISER MANIFOLD L>R			B10-1893
2	RISER MANIFOLD R>L			B10-1894
3	RISER MANIFOLD SC-8 / SC-9			B10-1391
4	YOKE ORIENT SPRAY PIPE			A10-1921
5	PIPE SPRAY POWER RINSE 18-3/4"			B10-1061
	PIPE SPRAY POWER RINSE 19-5/8" SC-9			B10-1060
6	CLAMP HAND SPRAY PIPE (CAP)			A10-1902
7	BRACKET SUPPORT UPPER SPRAY PIPE			A10-1922
8	SPRAY JET S.S.			B50-1135
9	BRACKET LOWER SPRAY PIPE SUPPORT			B10-1897
10	GASKET "2840"			A57-1419
11	TUBE DISCHARGE ASSM. R>L			B10-2147
12	TUBE DISCHARGE ASSM. L>R			B10-1901
13	GASKET "2802"			A57-1341
14	FLANGE SUCTION ASSM. 1-1/4" NPT			A10-1390
15	LOCKNUT CONDUIT 1-1/4" NPT			P52-1031
16	SEALING RING 1-1/4" NPT			P52-1032
17	FLANGE ADAPTOR DISCHARGE TUBE 1" R-L			A10-1904
18	FLANGE ADAPTOR DISCHARGE TUBE 1" L-R			A10-1900
19	LOCKNUT CONDUIT 1" NPT			P52-1034
20	SEALING RING 1" NPT			P52-1033

\* TO ORDER SUPPLY MACHINE MODEL AND SERIAL NUMBER

# STEAM COIL/INJECTOR ASSEMBLY

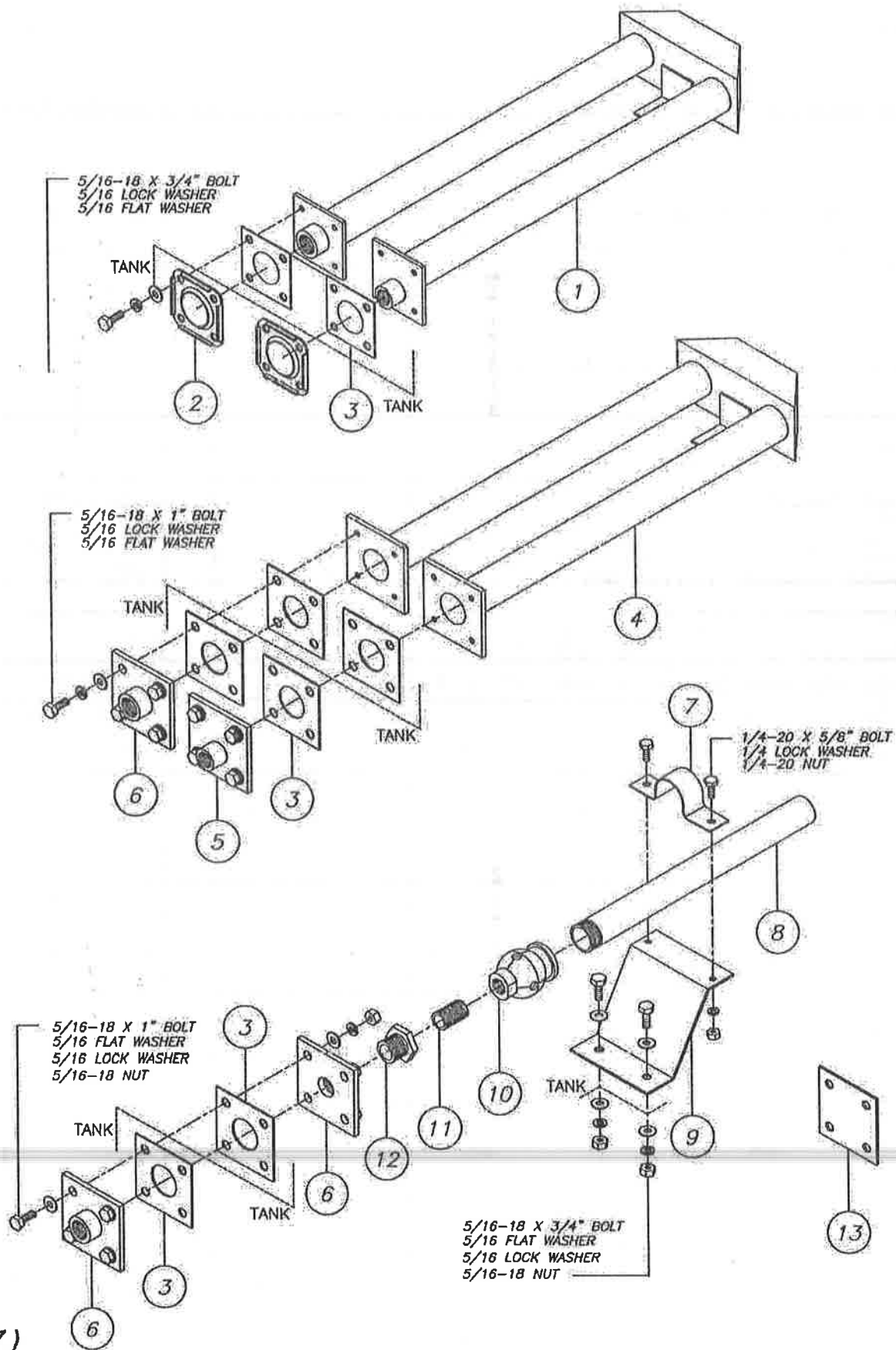

## STEAM COIL/INJECTOR ASSEMBLY

ITEM	DESCRIPTION	REMARKS	REQ.	PART NO.
1	NEW STYLE STEAM COIL ASSM. (WHEN ORDERING FACTORY REQUIRES MODEL & SERIAL NUMBER)			C10-4617A
2	FLANGE			B10-1505
3	GASKET STEAM COIL PIPE FLANGE			A57-2387
4	STEAM COIL ASSM. (WHEN ORDERING FACTORY REQUIRES MODEL & SERIAL NUMBER)			C10-4617
5	FLANGE RETURN ADAPTER 1/2" NPT			A10-3329
6	FLANGE INLET ADAPTER 3/4" NPT			A10-3332
7	STEAM INJECTOR PIPE CLAMP			A10-2163
8	STEAM INJECTOR PIPE 1" IPS			A10-2161
9	BRACKET PIPE SUPPORT STEAM INJECTOR			B10-2162
10	STEAM SILENCER			A10-2160
11	NIPPLE SS 1/2 CLOSE MIP			P68-1885
12	BUSHING SS 3/4 X 1/2 MXF			P68-1896
13	BLANK PLATE 3 X 3 SS			A10-3326

\* TO ORDER SUPPLY MACHINE MODEL AND SERIAL NUMBER ( 78 )

# CONVEYOR SIDE MOUNTED PUMP STEAM COIL ASSEMBLY

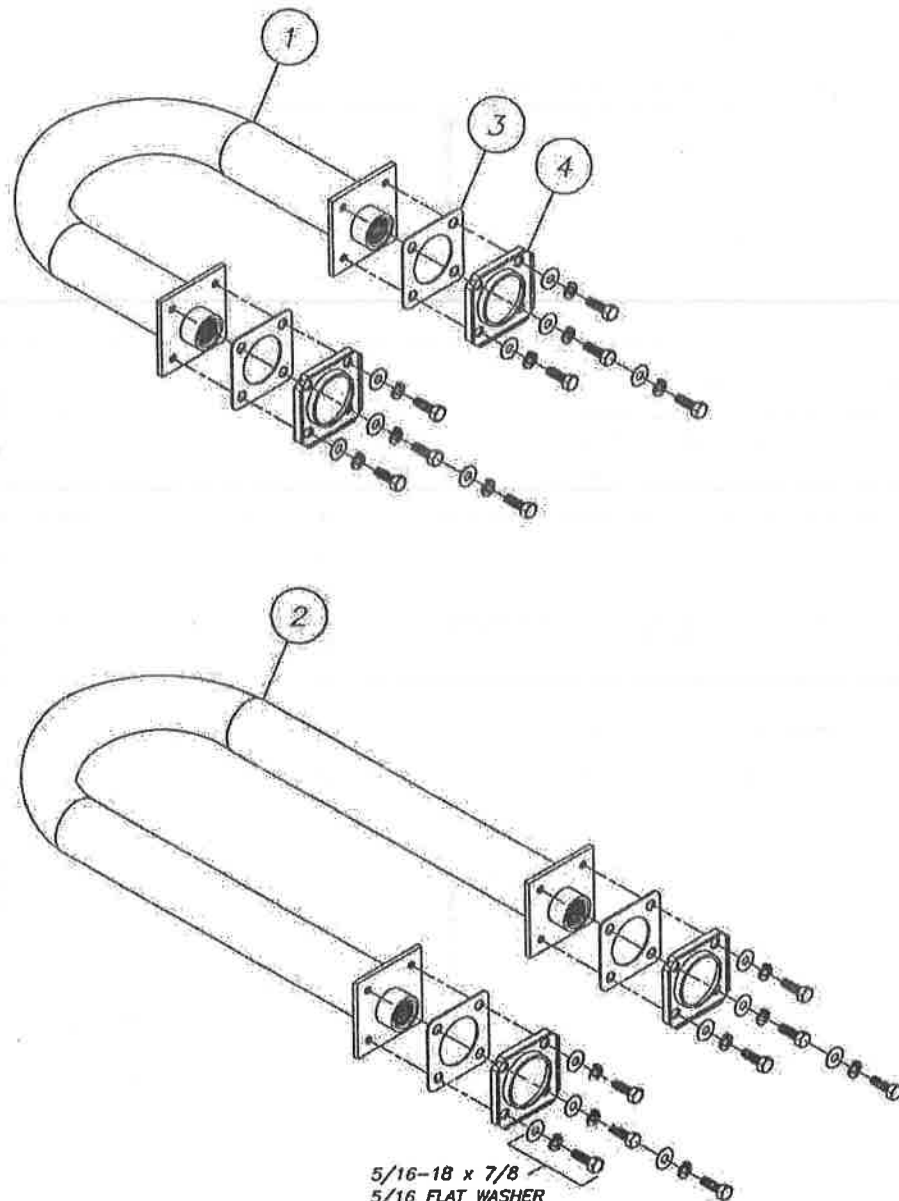

5/16-18 x 7/8  
5/16 FLAT WASHER  
5/16 LOCK WASHER  
(4) REQ. PER SIDE





# OLD STYLE GAS HEATER ASSEMBLY

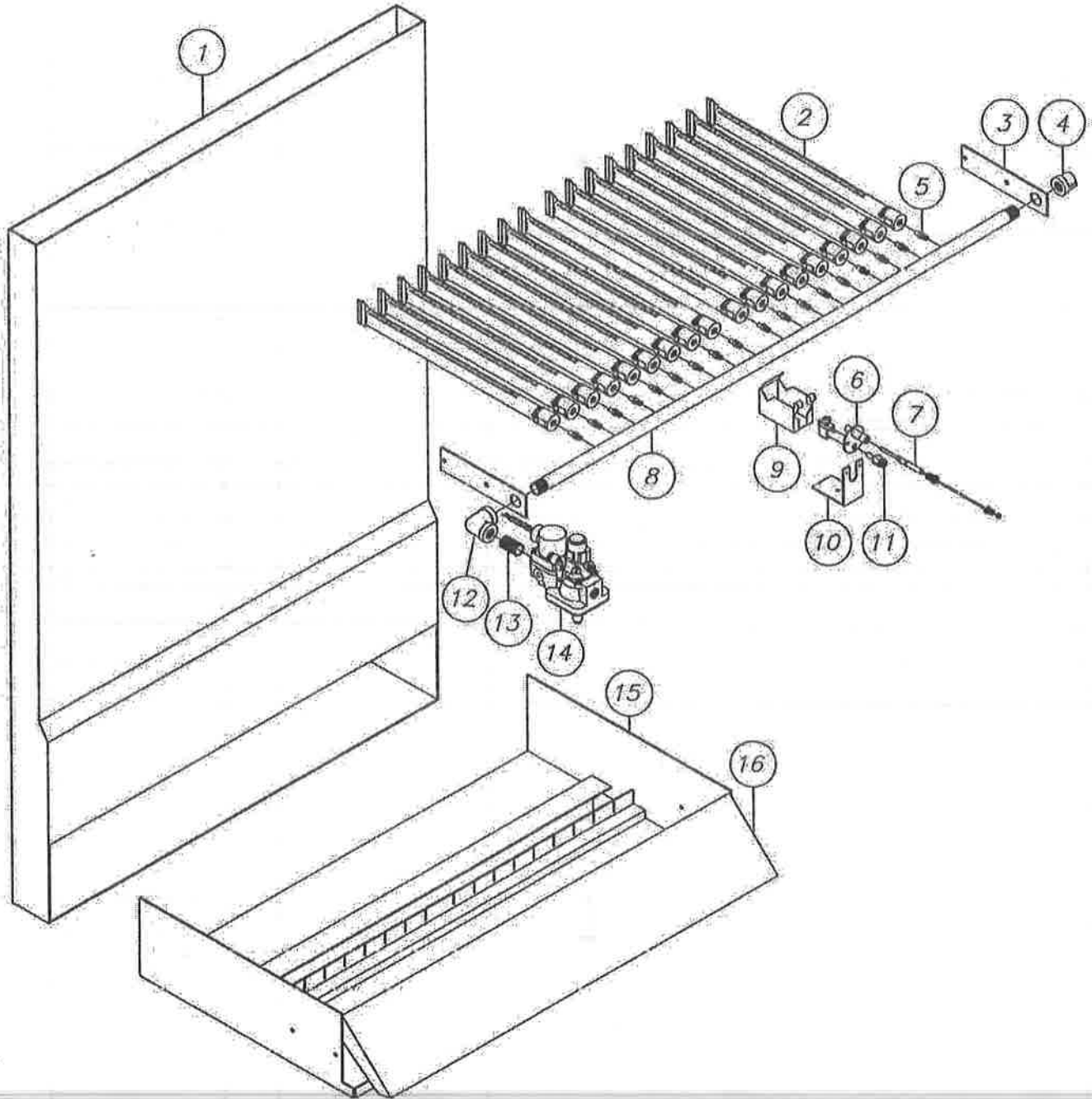

## OLD STYLE GAS HEATER ASSEMBLY

ITEM	DESCRIPTION	REMARKS	REQ.	PART NO.
1	FLUE BURNER BOX (12 BURNERS)	NLA		C10-2371
	FLUE BURNER BOX (18 BURNERS)	NLA		C10-2372
2	BURNER BLADES			A55-2375
3	BRACKET GAS HEAT FLUE			A10-1613
4	CAP BI 1/2" BIP			P67-1599
5	ORIFICE BURNER BLADE NATURAL GAS			A54-2376
	ORIFICE BURNER BLADE LIQUID PROPANE			A10-2377
6	PILOT BURNER			P54-2005
7	THERMOCOUPLE			P54-2004
8	GAS PIPE (12 BURNERS)			B10-2373
	GAS PIPE (18 BURNERS)			B10-2374
9	BURNER BOX PILOT HOUSING	NLA		B10-2386
10	BRACKET PILOT BURNER			A10-4190
11	ORIFICE LIQUID PROPANE PILOT BURNER			P54-2006
	ORIFICE NATURAL GAS PILOT BURNER			P54-2007
12	ELBOW BI 90° 1/2" FIP			P68-1596
13	NIPPLE BI 1/2" CLOSE			P68-1654
14	GAS VALVE LIQUID PROPANE 208/240 V	NLA		P54-2001
	GAS VALVE NATURAL 120 V	NLA		P54-2002
	GAS VALVE NATURAL 208/240 V			P54-2003
15	BURNER BOX (12 BURNERS)	NLA		C10-2369
	BURNER BOX (18 BURNERS)	NLA		C10-2370
16	BURNER BOX DOOR	NLA		*

\* TO ORDER SUPPLY MACHINE MODEL AND SERIAL NUMBER

# INFRARED GAS TANK HEAT ASSEMBLY

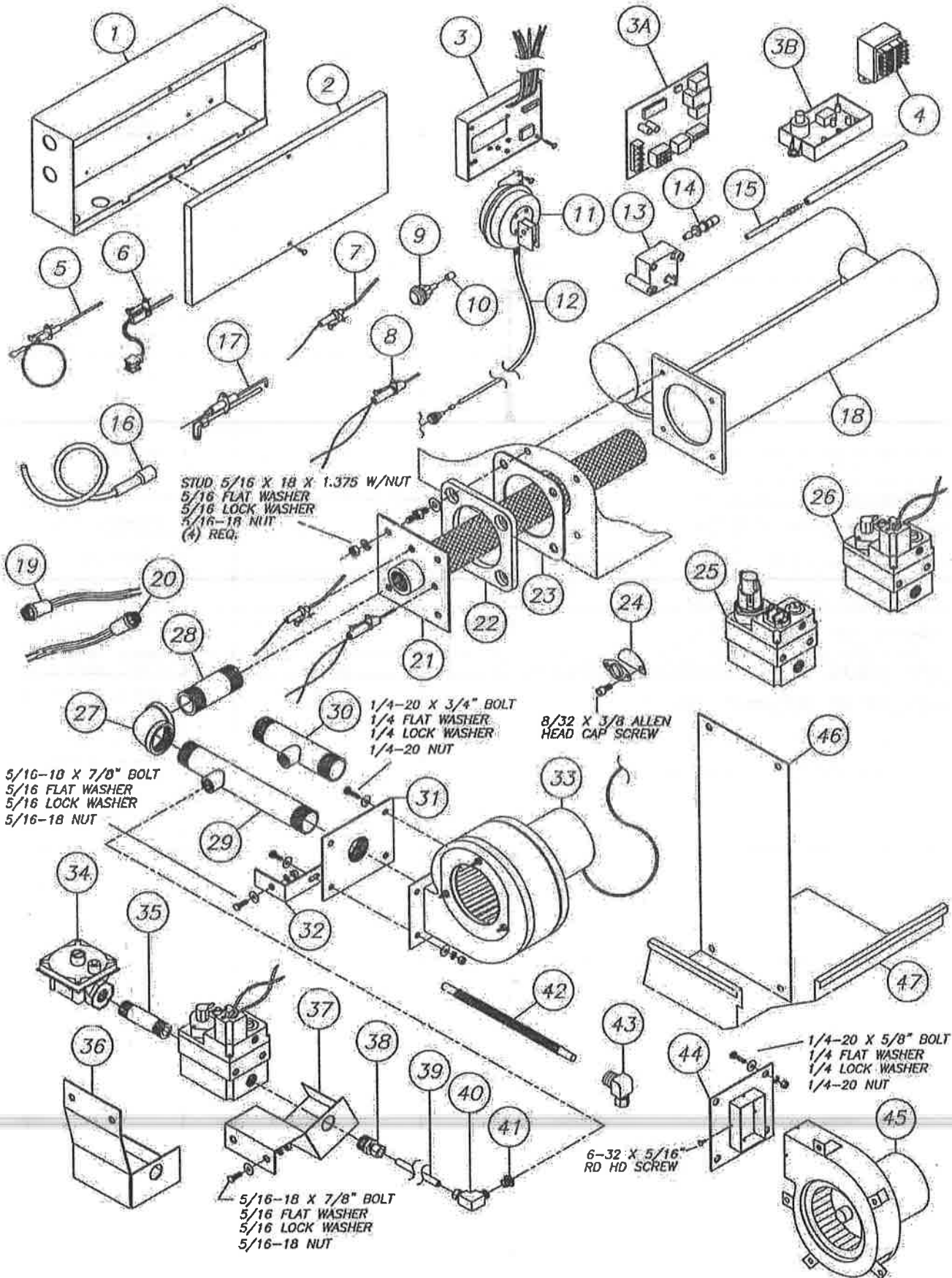

## INFRARED GAS TANK HEAT ASSEMBLY

ITEM	DESCRIPTION	REMARKS	PART NO.
1	BOX, 14" X 5" X 4" GAS CONTROL		C10-5956
2	COVER, 14" GAS CONTROL		B10-5957
3	CONTROL MODULE MARK 17X MODEL 2020-45		P42-5944
3A	CONTROL MODULE INTELL INTERGRATED NO. 50A65	'02-present	P42-6283
3B	CONTROL MODULE SPARK IGNITION SYSTEM	'00-'01	P42-6215
4	TRANSFORMER PRI. 115/230 SEC. 24V.		P53-1054
5	FLAME SENSOR NO. 760-401	'02-present	P49-6288
6	SILICON NITRIDE IGNITER NO. 768A-7	'02-present	P49-6287
7	FLAME SENSOR	1990's	P49-6037
8	HOT WIRE IGNITER 601T MODEL MB460069	1990's	P49-5798
9	FITTING VACUUM VALVE TUBE		A10-5822
10	SNUBBER RESTRICTOR 132083		A10-5831
11	DIAPHRAGM SWITCH		P49-5795
12	TUBE CLEAR 5/16 OD. 3/16 ID.		P51-5829
13	DIAPHRAGM SWITCH MODEL MDA-011		P49-6307
14	3/16 X 1/8 BARB REDUCER POLY		S67374
15	TUBE CLEAR 1/4 OD. 1/8 ID.		P51-6360
16	SPARK PLUG WIRE 36" HIGH VOLTAGE CABLE		P45-5797
17	SPARK IGINTOR IR NATURAL GAS	'00-'01	P49-6213
	SPARK IGINTOR IR LP GAS	'00-'01	P49-6214
18	STAINLESS STEEL BURNER TUBE ASSEMBLY		A10-5802
19	PILOT LIGHT RED 24V. 1/2" OD.		P49-6295
20	PILOT LIGHT RED 115V. 1/2" OD.		P49-5788
21	INFRARED BURNER MODEL 621622-SC		P55-5792
22	INFRARED BURNER PLATE ADAPTER		A10-6257
23	BURNER PLATE GASKET		B57-1757
24	BURNER SIGHT-GLASS WITH BRACKET		A10-5826
25	GAS VALVE 1/2" IPS 24V. NO. 36C01-405		P54-6289
26	GAS VALVE 1/2" IPS 115V.		P54-5796
27	ELBOW 1" F X F		P68-1622
28	NIPPLE 1" X 3"		P68-1638
29	MIXING CHAMBER EXTENDED 8-1/2"		A10-6001
30	MIXING CHAMBER 5"		A10-5821
31	ADAPTER, BLOWER		A10-5812
32	BRACKET, BLOWER MOUNTING		A10-5809
33	FASCO BLOWER 115V. RPM 3200 NO. 702110883		P41-5793
34	REGULATOR, GAS PRESSURE		P54-5828
35	NIPPLE 1/2" X 2-1/2"		P68-1657
36	BRACKET, GAS VALVE MOUNTING MULTI TANK		A10-5808
37	BRACKET, GAS VALVE MOUNTING SINGLE TANK		A10-5810
38	COMP FIT 3/8" OD. X 1/2" MIP		P68-5830
39	TUBE, 3/8" COPPER		P51-2013
40	FITTING, ORIFICE HOLDER		A10-5832
41	ORIFICE (SPECIFY NATURAL GAS OR PROPANE		A54-5827
42	GAS FLEX LINE 3/8" OD X 12"		P68-6144
	GAS FLEX LINE 3/8" OD X 18"		P68-6145
43	COMP FIT 3/8" OD. X 1/2" MIP 90 DEGREE		P68-5890
44	ADAPTER, BLOWER		A10-6052
45	FASCO BLOWER 115V. RPM 3000 MODEL A079		P41-6082
46	S/S SPLASH SHIELD		*
47	S/S SPLASH SHIELD		*

\* TO ORDER SUPPLY MACHINE MODEL AND SERIAL NUMBER

( 84 )

# INFRARED EXHAUST ASSEMBLY

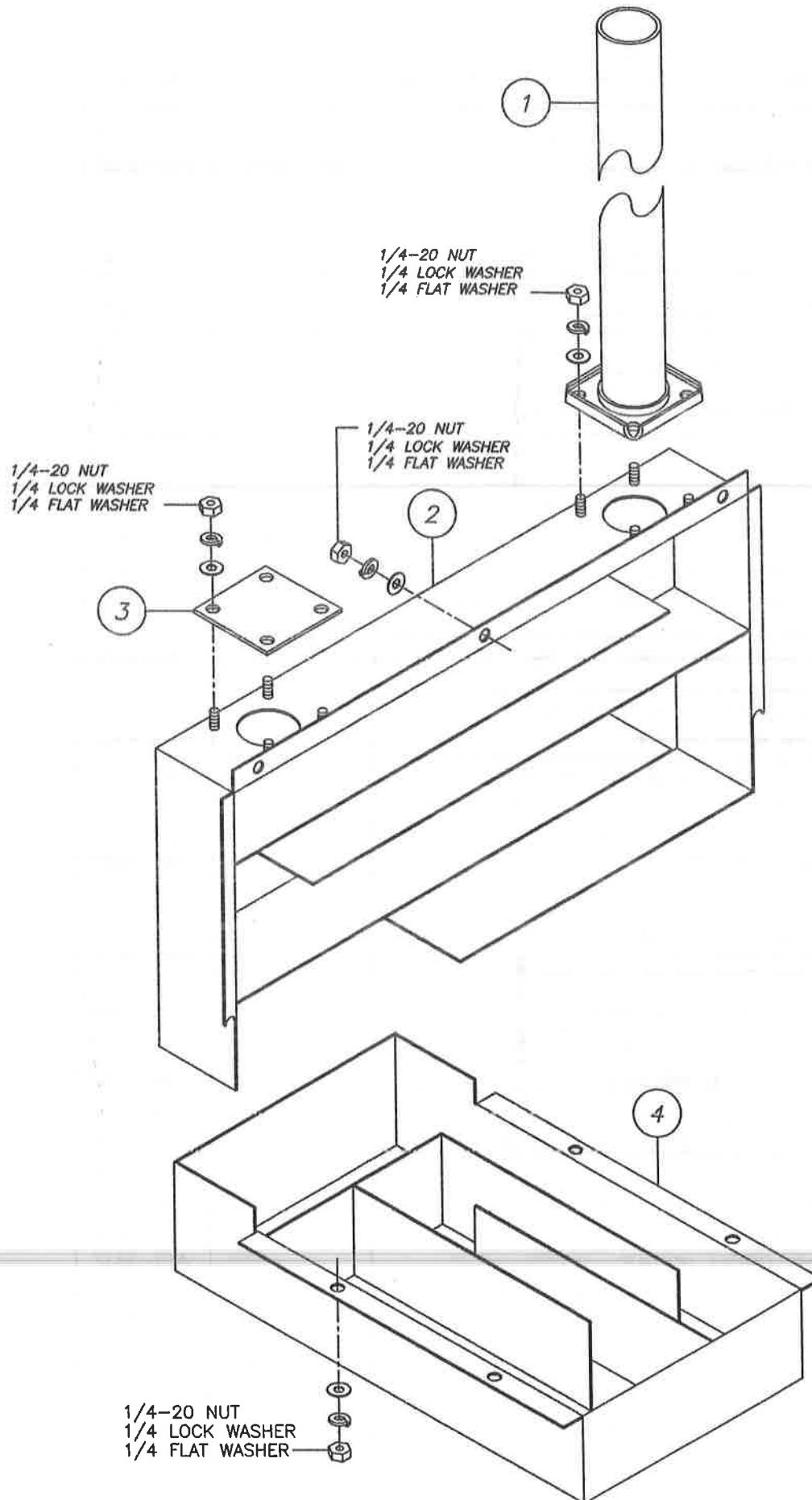

**INFRARED EXHAUST ASSEMBLY**

ITEM	DESCRIPTION	REMARKS	REQ.	PART NO.
1	TUBE, EXHAUST	S# REQ'D		A10-5820
2	BOX, SECONDARY HEAT RECIRCULATING	S# REQ'D		C10-5813
3	BLANK PLATE 3X3 SS	S# REQ'D		A10-3326
4	BOX, PRIMARY HEAT RECIRCULATING	S# REQ'D		C10-5816

# HEATING ELEMENTS AND ENCLOSURES

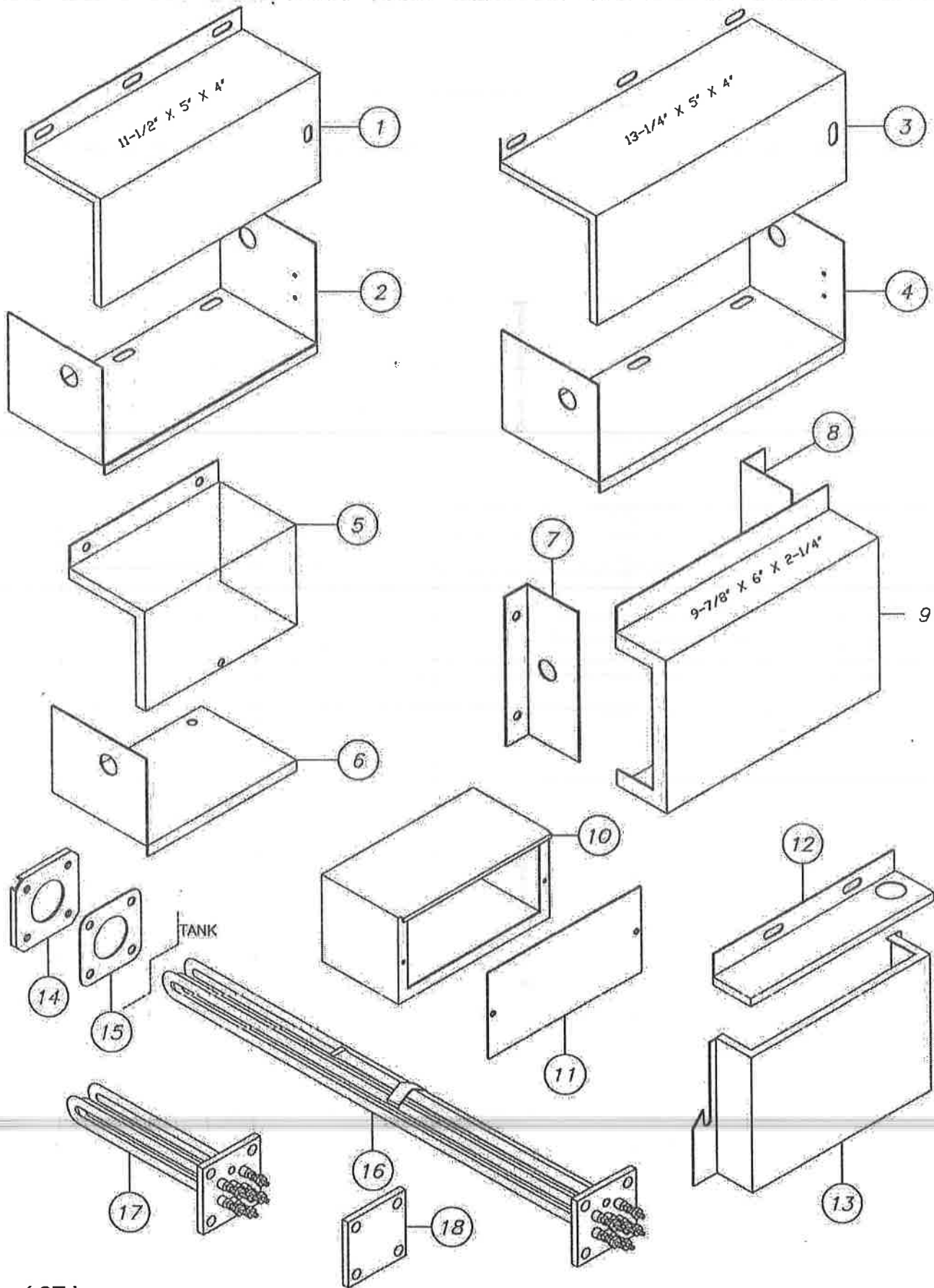



## HEATING ELEMENTS AND ENCLOSURES

ITEM	DESCRIPTION	REMARKS	REQ.	PART NO.
1	HEATING ELEMENT SHIELD 11.5" X 5" X 4"	MODULAR		A10-5350
2	HEATING ELEMENT BOTTOM BOX	MODULAR		A10-5351
3	HEATING ELEMENT SHIELD 13.5" X 5" X 4"	SCT 44 & 66S		A10-5340
4	HEATING ELEMENT BOTTOM BOX	SCT 44 & 66S		A10-5341
5	HEATING ELEMENT SHIELD 9" X 5" X 4"	MODULAR		A10-4545
6	HEATING ELEMENT BOTTOM BOX	MODULAR		A10-1855
7	HEATING ELEMENT END SHIELD			*
8	HEATING ELEMENT END SHIELD			*
9	HEATING ELEMENT SHIELD 9.875" X 6" X 2.25"			A10-6028
10	ELEMENT ENCLOSURE BOX 10KW OLD STYLE			B10-2799
11	ELEMENT ENCLOSURE COVER OLD STYLE			A10-2800
12	HEATING ELEMENT TOP SHIELD			*
13	HEATING ELEMENT SHIELD			A10-3706
14	HEATING ELEMENT FLANGE			B10-1502
15	HEATING ELEMENT GASKET			A57-1114
16	HEATING ELEMENTS 5KW 208V.	19.5"		P55-1131
	HEATING ELEMENTS 5KW 240V.	19.5"		P55-1132
	HEATING ELEMENTS 5KW 480V.	19.5"		P55-1133
	HEATING ELEMENTS 7.5KW 208V.	19.5"		P55-5609
	HEATING ELEMENTS 7.5KW 240V.	19.5"		P55-6148
	HEATING ELEMENTS 7.5KW 480V.	19.5"		P55-5657
17	HEATING ELEMENTS 4KW 208V.	8"		P55-6387
	HEATING ELEMENTS 4KW 240V.	8"		P55-6388
	HEATING ELEMENTS 4KW 480V.	8"		P55-6389
18	HEATING ELEMENT PLATE BLANK			A10-3326

\* TO ORDER SUPPLY MACHINE MODEL AND SERIAL NUMBER

# HEAT ENCLOSURES

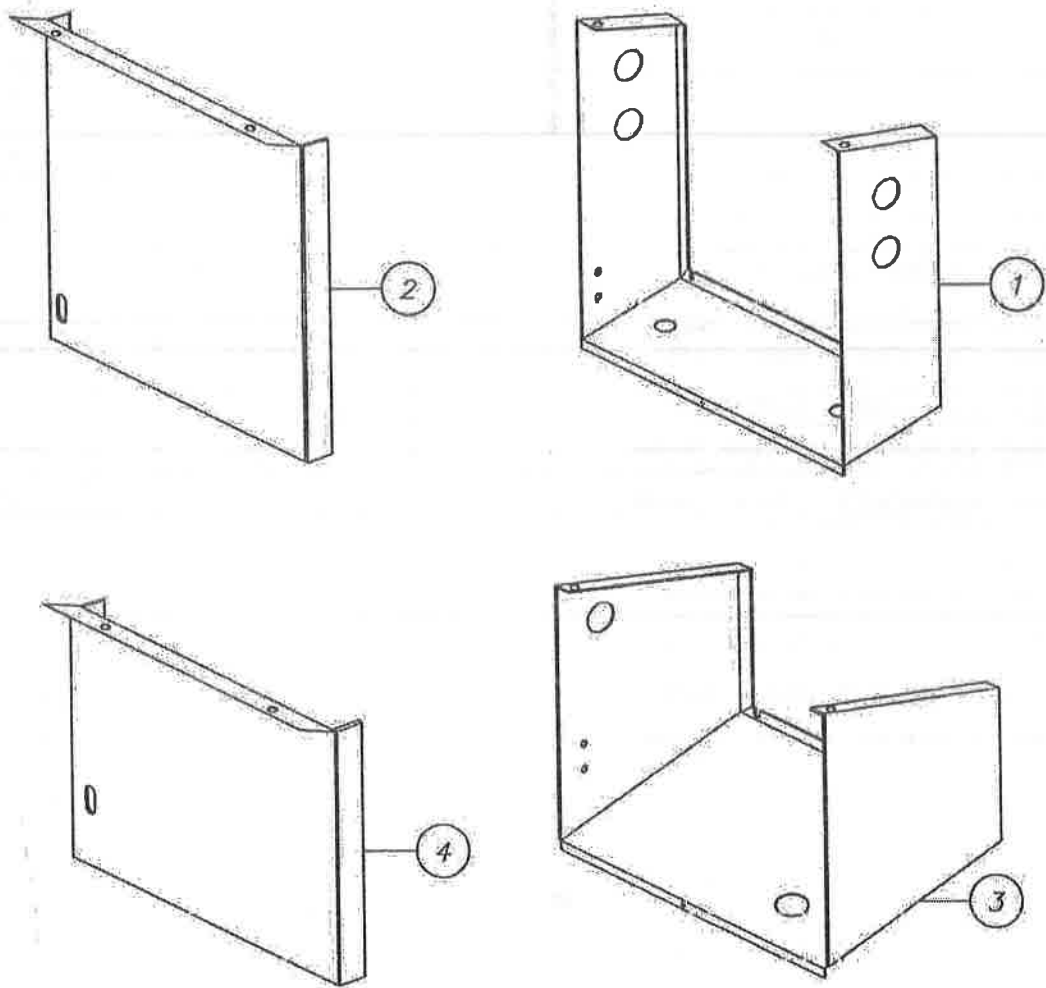



# BLOWER DRYER TANK ASSEMBLY

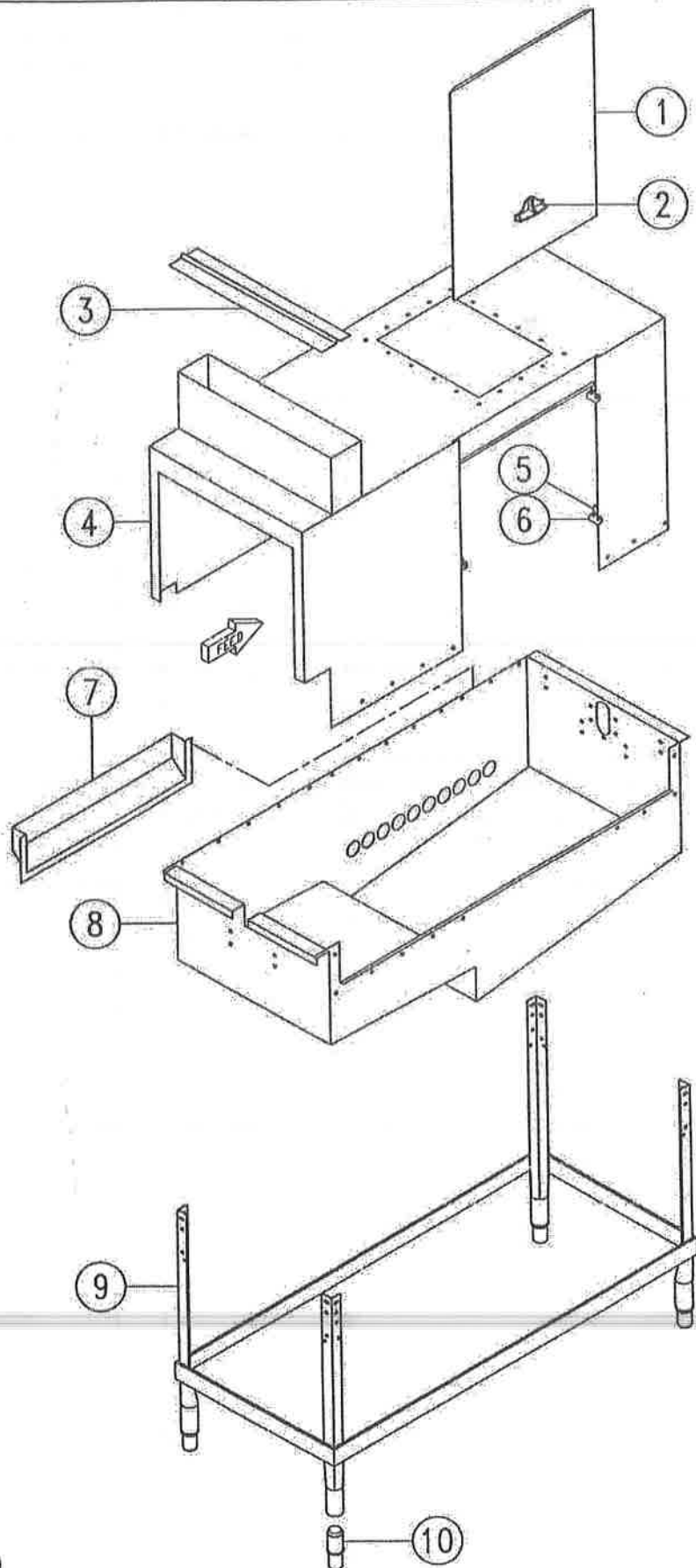



# BLOWER DRYER

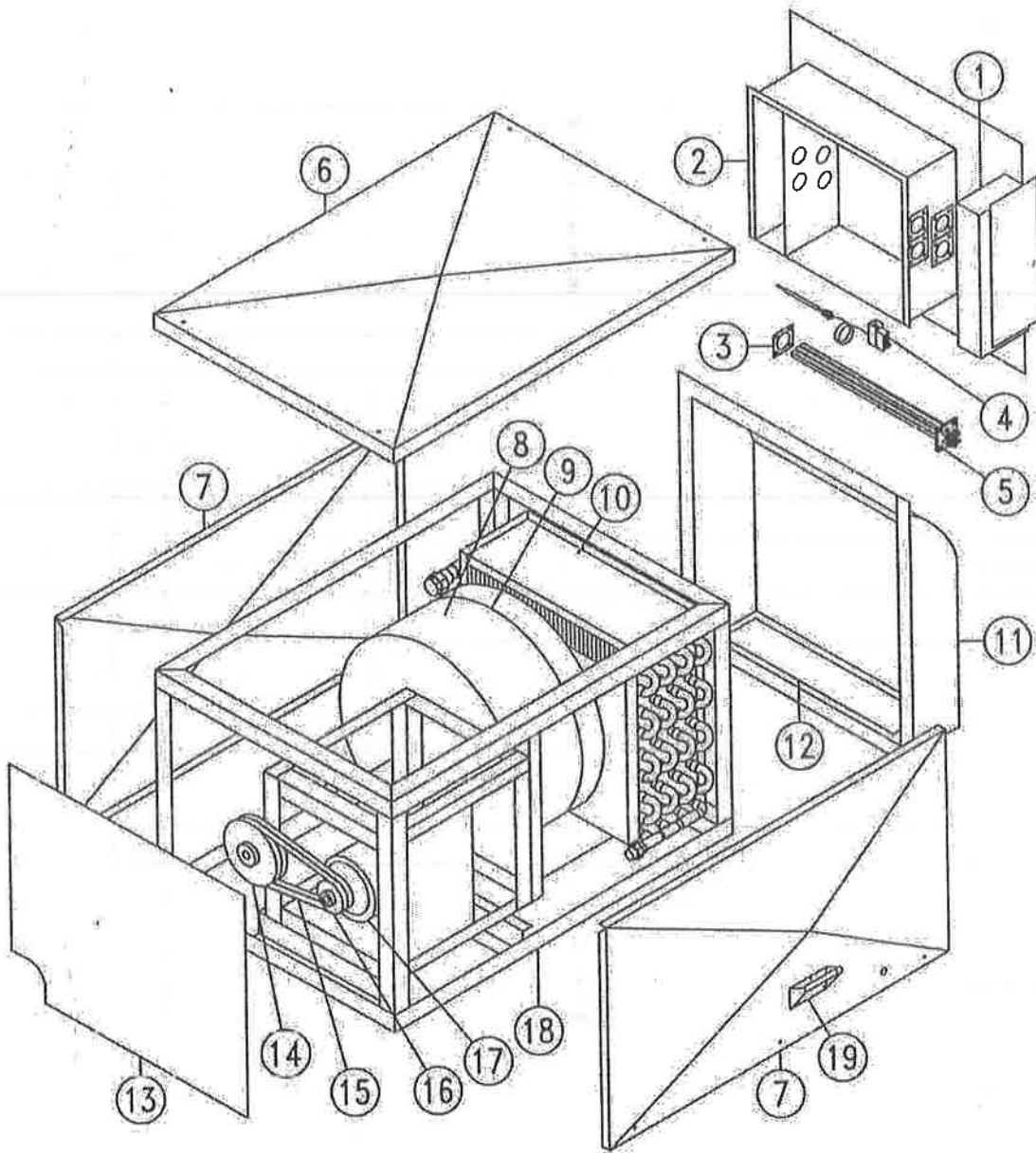



# STEAM BOOSTERS

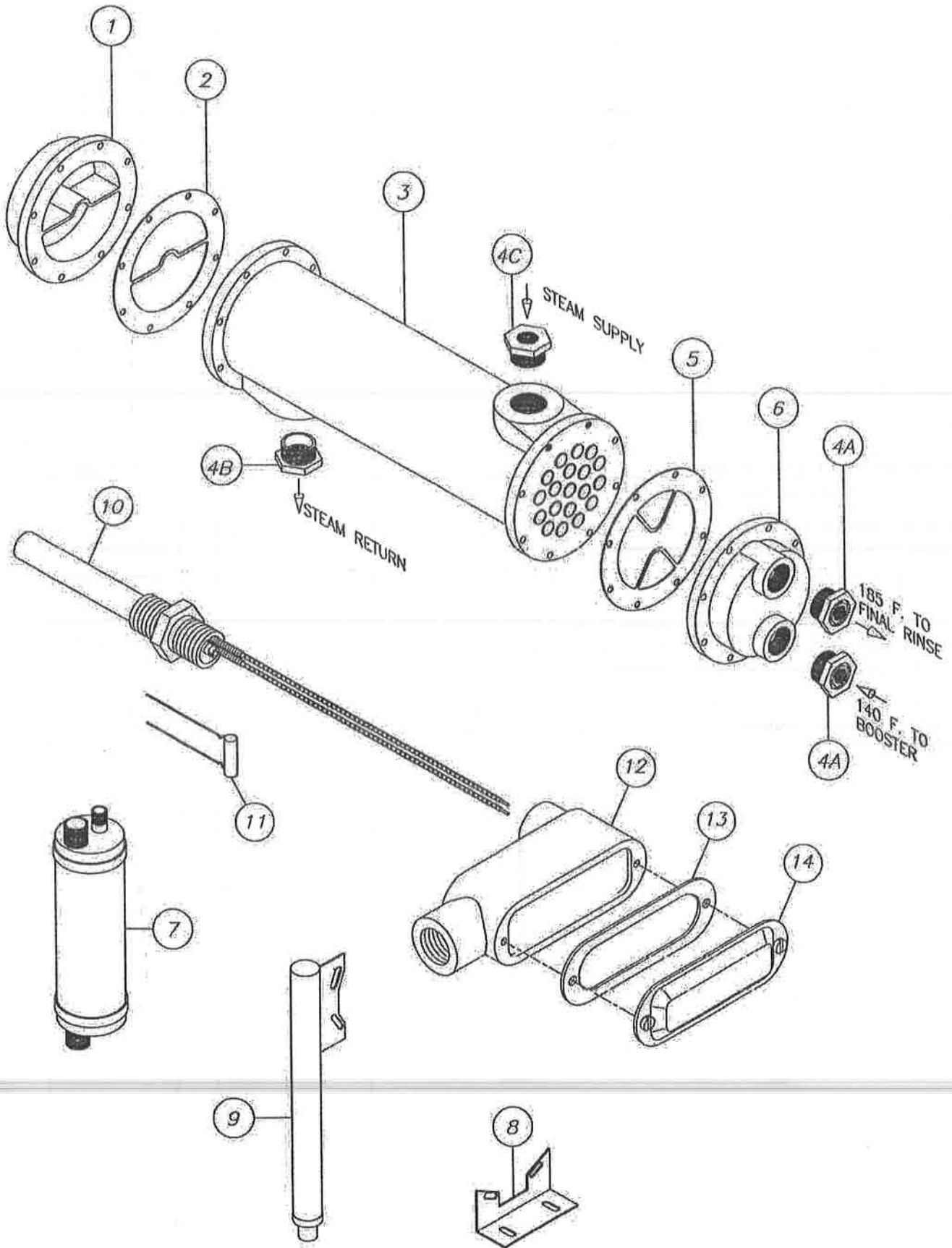



## STEAM BOOSTERS

ITEM	DESCRIPTION	REMARKS	REQ.	PART NO.
1	HEADER THERMOSTAT END	(180)		P64-1964
	HEADER THERMOSTAT END	(260-380)		C10-2238
2	GASKET RETURN END	(180)		B57-1278
	GASKET RETURN END			B57-2236
3	HEAT EXCHANGER #180 (INCLUDES			P64-1960
	ITEMS 1,2,5, & 6)			
	HEAT EXCHANGER #260 (INCLUDES			P64-1961
	ITEMS 1,2,5, & 6)			
	HEAT EXCHANGER #320 (INCLUDES			P64-1962
	ITEMS 1,2,5, & 6)			
	HEAT EXCHANGER #380 (INCLUDES			P64-1963
	ITEMS 1,2,5, & 6)			
4A	BUSHING GALV. 1-1/4 X 3/4 MXF	(180)	2	P68-1563
	BUSHING GALV 2 X 3/4 MXF	(260-380)	2	P68-1610
4B	BUSHING BI 1-1/2 X 1/2 MXF	(180)		P68-1562
	BUSHING BI 2 X 3/4 MXF	(260-380)		P68-1608
4C	BUSHING BI 1-1/2 X 3/4 MXF	(180)		P68-1561
	BUSHING BI 2 X 1-1/4 MXF	(260-380)		P68-1607
5	GASKET FLOW END	(180)		B57-2234
	GASKET FLOW END	(260-380)		B57-2235
6	HEADER FLOW END	(180)		P64-1965
	HEADER FLOW END	(260-380)		P64-1966
7	SPIREC K-1 BOOSTER			P64-2810
	SPIREC K-2 BOOSTER			P64-2811
	SPIREC K-3 BOOSTER			P64-5160
8	BRACKET MACHINE MOUNTING			A10-3225
9	LEG STEAM BOOSTER SWB180-380			A10-3350
10	THERMOSTAT CONTACTS OPEN ON RISE			P65-1183
	USED ON STEAM BOOSTERS.			
11	CAPACITOR .001-600V			P41-2462
12	UNILET BODY (USED WITH P65-1183)			P52-2014
13	GASKET 1/2" NEO			P52-2018
14	COVER 1/2" JUNCTION BOX			P52-2019

\* TO ORDER SUPPLY MACHINE MODEL AND SERIAL NUMBER

(96)

# PARKER SOLENOID VALVES / REPAIR KITS AND COILS

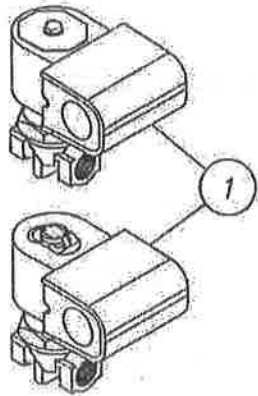

3/8" NPT PARKER SOLENOID VALVE

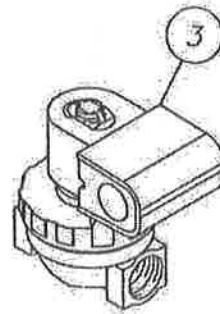
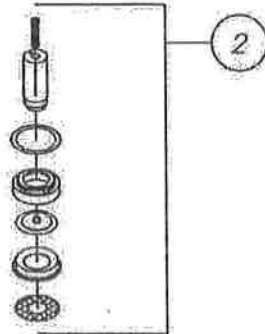

3/4" NPT PARKER SOLENOID VALVE

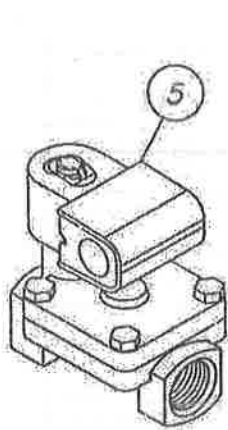
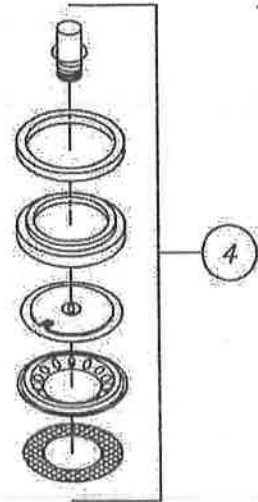

1" NPT PARKER SOLENOID VALVE

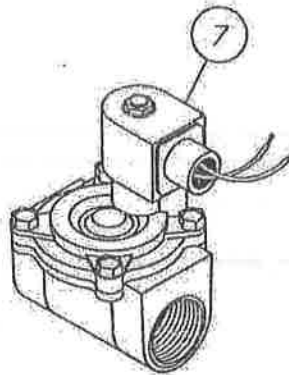
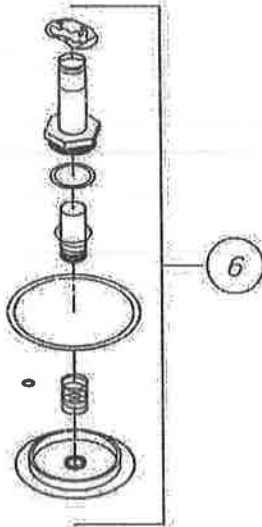

1-1/4" NPT PARKER SOLENOID VALVE

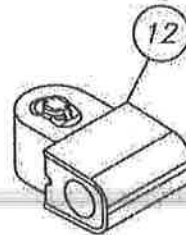
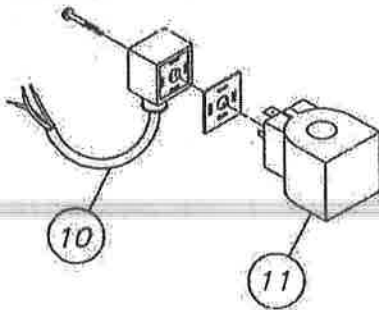
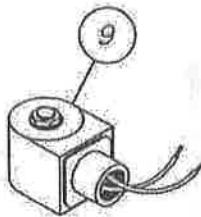
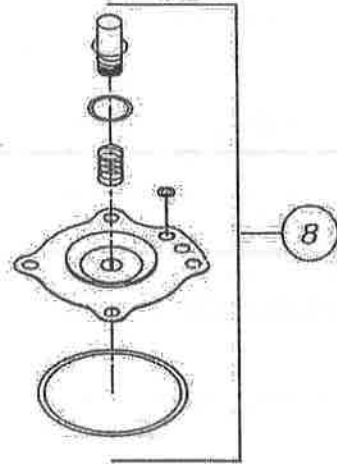

# PARKER SOLENOID VALVES / REPAIR KITS AND COILS

ITEM	DESCRIPTION		REMARKS	PART NO.
1	3/8" VALVE 120V.	PARKER	B70411A77310	P54-2051
	3/8" VALVE 208-240V.	PARKER	70411A77320	P54-6394
	3/8" VALVE 24V.	PARKER	70411A77300	P54-6395
2	3/8" VALVE REPAIR KIT	PARKER	P54-2051 & 6394	P54-5339
3	3/4" VALVE 120V.	PARKER	12FS5C2Z05ACHDS	P54-6245
	3/4" VALVE 208-240V.	PARKER	12FS5C2Z05ACHDS	P54-6246
4	3/4" VALVE REPAIR KIT	PARKER	L60S016 (NLA)	P54-1067
	3/4" VALVE REPAIR KIT	PARKER		P54-6247
5	1" VALVE 120V.	PARKER	16FS5C2Z02ACHD	P54-6250
	1" VALVE 208-240V.	PARKER	16FS5C2Z02ACHD	P54-6251
6	1" VALVE REPAIR KIT	PARKER	16FS5C2-Z02R	P54-6252
7	1-1/4" VALVE 120V.	PARKER		P54-1068
	1-1/4" VALVE 208-240V.	PARKER		P54-1069
8	1-1/4" VALVE REPAIR KIT	PARKER	L60-S067	P54-1070
9	COIL 120V. 1-1/4"	SKINNER-HONEYWELL	C222P3	P54-5735
	COIL 208V. 1-1/4"	SKINNER-HONEYWELL	C2222K	P54-5736
	COIL 240V. 1-1/4"	SKINNER-HONEYWELL	C222Q3	P54-5737
10	CABLE DIM MOLDED	PARKER	U27-037	P54-6512
11	COIL 24V. DIN 3/8"-3/4"	PARKER	CFPH01	P54-6509
	COIL 120V. DIN 3/8"-3/4"	PARKER	CFPH05	P54-6510
	COIL 240V. DIN 3/8"-3/4"	PARKER	CFPH15	P54-6511
12	COIL 120V. 3/4"-1"	PARKER	CHDS05	P54-6248
	COIL 208-240V. 3/4"-1"	PARKER	CHDS12	P54-6249

\* TO ORDER SUPPLY MACHINE MODEL AND SERIAL NUMBER

# ASCO SOLENOID VALVES - REPAIR KITS AND COILS

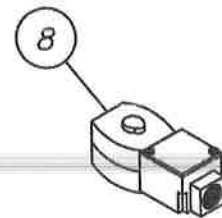
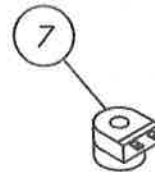
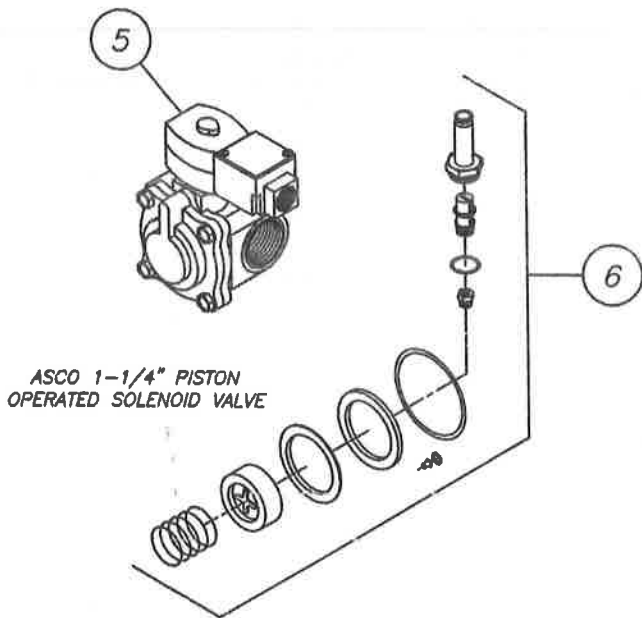
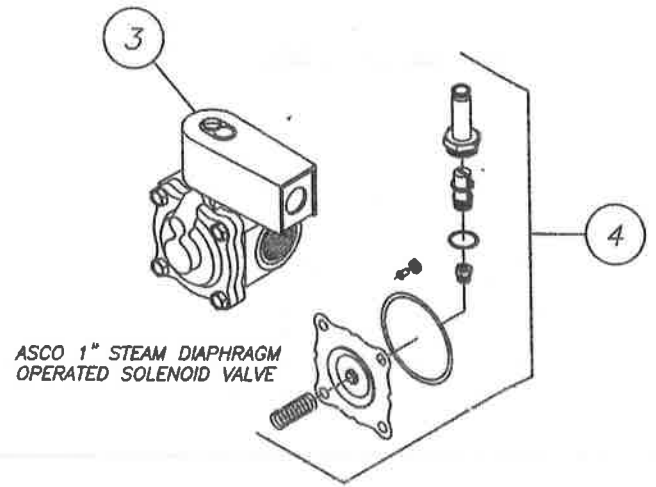
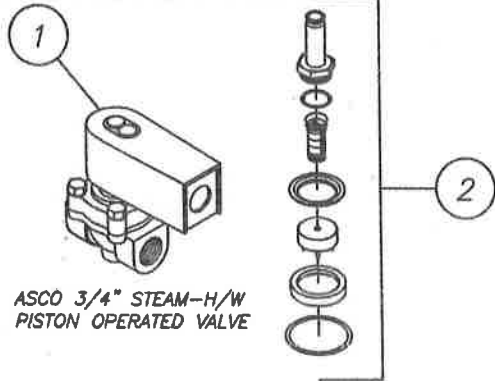

### ASCO SOLENOID VALVES - REPAIR KITS AND COILS

ITEM	DESCRIPTION	REMARKS	REQ.	PART NO.
1	3/4" VALVE 120V. STEAM/HW PISTON	ASCO		P54-2815
	3/4" VALVE 208/240V. STEAM/HW PISTON	ASCO		P54-2816
2	3/4" VALVE REPAIR KIT PISTON OPERATED	ASCO		P54-2821
	3/4" VALVE DIAPHRAGM OPERATED	ASCO		NLA
3	1" VALVE 120V. STEAM DIAPHRAGM OPERATED	ASCO		P54-2840
	1" VALVE 208 OR 240V. STEAM DIAPHRAGM	ASCO		NLA
4	1" VALVE REPAIR KIT STEAM DIA. OPERATED	ASCO		P54-2842
5	1-1/4" VALVE 120V. STEAM/HW PISTON	ASCO		P54-2819
	1-1/4" VALVE 208V. STEAM/HW PISTON	ASCO		P54-2830
	1-1/4" VALVE 240V. STEAM/HW PISTON	ASCO		NLA
6	1-1/4" VALVE REPAIR KIT STEAM/HW PISTON	ASCO		P54-2829
	1-1/4" VALVE STEAM DIAPHRAGM OPERATED	ASCO		NLA
7	COIL 120V. 3/4" VALVE PISTON OPERATED	ASCO		P54-2808
	COIL 208/240V. 3/4" VALVE PISTON OPERATED	ASCO		P54-2825
	COILS FOR 1" ASCO DIAPHRAGM VALVES	ASCO		NLA
8	COIL 120V. 1-1/4" VALVE PISTON OPERATED	ASCO		P54-2828
	COIL 208V. 1-1/4" VALVE PISTON OPERATED	ASCO		P54-5261
	COIL 240V. 1-1/4" VALVE PISTON OPERATED	ASCO		NLA

\* TO ORDER SUPPLY MACHINE MODEL AND SERIAL NUMBER

# COMMON PLUMBING PARTS

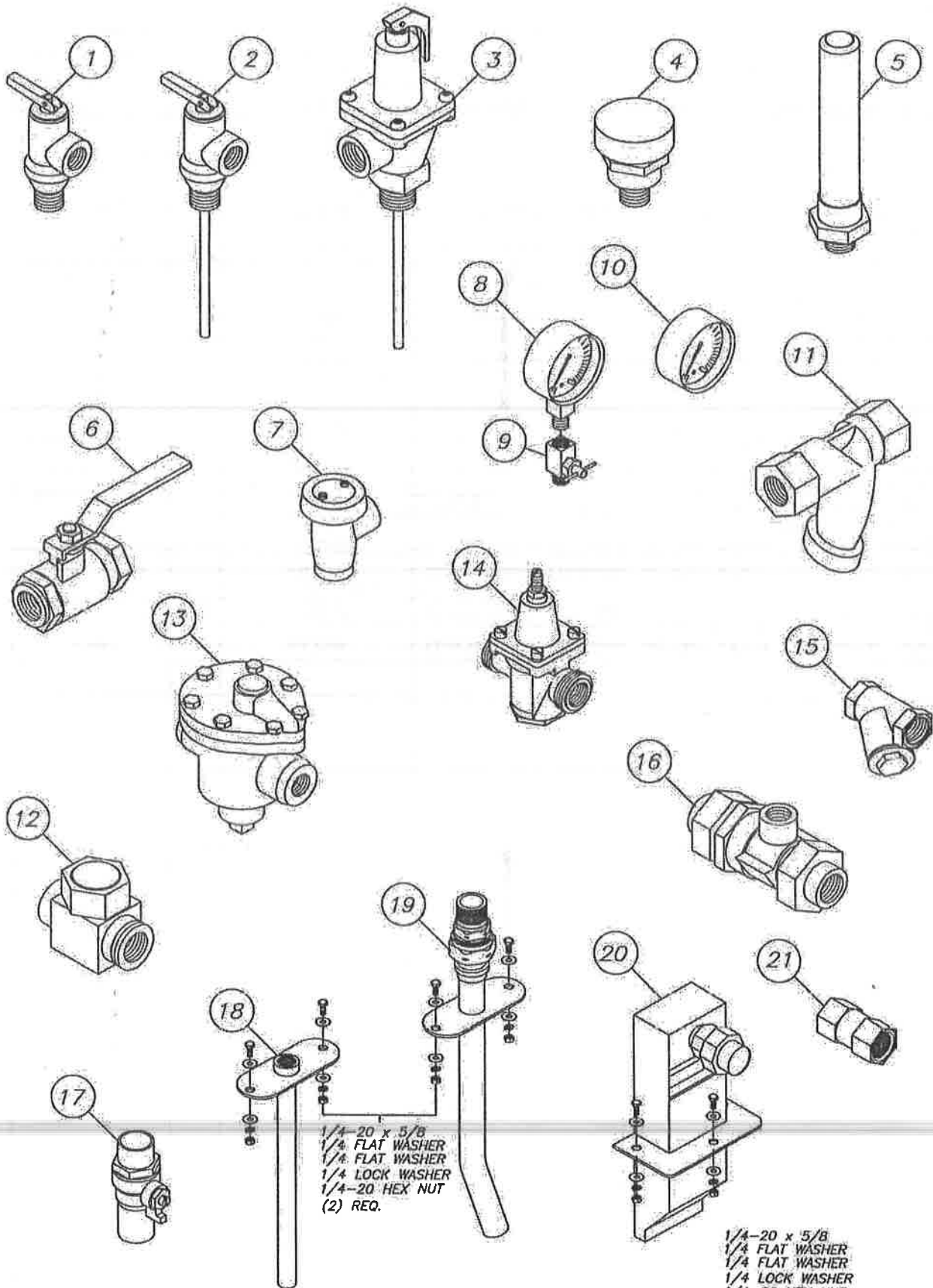

1/4-20 x 5/8  
 1/4 FLAT WASHER  
 1/4 FLAT WASHER  
 1/4 LOCK WASHER  
 1/4-20 HEX NUT  
 (2) REQ.

1/4-20 x 5/8  
 1/4 FLAT WASHER  
 1/4 FLAT WASHER  
 1/4 LOCK WASHER  
 1/4-20 HEX NUT  
 (3) REQ.

## COMMON PLUMBING PARTS

ITEM	DESCRIPTION	REMARKS	REQ.	PART NO.
1	1/2" VALVE PRESSURE RELIEF 125PSI	(53L)		P62-1919
	3/4" VALVE PRESSURE & TEMP RELIEF	(3L)		P62-1171
2	3/4" VALVE PRESSURE & TEMP RELIEF	(100XL)		P62-1174
3	3/4" VALVE PRESSURE & TEMP RELIEF	(40XL-5)		P62-1173
4	1/2" VALVE VACUUM RELIEF	(N36)		P62-1170
5	3/4" SHOCK ARRESTOR	*		P62-2250
6	1/2" BALL VALVE	*		P62-1182
	3/4" BALL VALVE	*		P62-2453
	1" BALL VALVE	*		P62-5755
7	3/8" VACUUM BREAKER COMPLETE	*		P62-6374
	1/2" VACUUM BREAKER COMPLETE	*		P62-1150
	3/4" VACUUM BREAKER COMPLETE	*		P62-1149
	3/8" VACUUM BREAKER	REPAIR KIT		P62-6681
	3/4" VACUUM BREAKER	REPAIR KIT		P62-1164
8	PRESSURE GAUGE 2.5" DIA 0-60 1/4" NPT.	BOTTOM MTD.		P65-1136
9	NEEDLE VALVE STR 1/4 X 1/4 MIPXFIP			P68-1511
10	PRESSURE GAUGE 2.5" DIA 0-30 1/4" NPT.	REAR MTD.		P65-5200
11	3/4" BRASS LINE STRAINER			P63-1115
	1" BRASS LINE STRAINER	*		P63-2251
	3/4" BRASS LINE STRAINER SCREEN	REPLACEMENT		P63-1117
	1" BRASS LINE STRAINER SCREEN	REPLACEMENT		P63-1923
	1/2" BLK. IRON LINE STRAINER	*		P63-1300
	1" BLK. IRON LINE STRAINER	*		P63-1158
	1-1/4" BLK. IRON LINE STRAINER	*		P63-1159
	2" BLK. IRON LINE STRAINER	*		P63-1160
12	1/2" THRMO-DYAMIC STEAM TRAP	WATTS		P61-1169
	3/4" THRMO-DYAMIC STEAM TRAP	WATTS		P61-1168
13	1/2" INVERTED BUCKET STEAM TRAP	*		P61-6041
	3/4" INVERTED BUCKET STEAM TRAP	*		P61-6042
14	3/4" PRESSURE REDUCING VALVE	*		P62-1166
	3/4" PRESSURE REDUCING VALVE	REPAIR KIT		P62-1167
15	3/4" CHECK VALVE	BRASS		P68-5602
	1" CHECK VALVE	BRASS		P68-6177
16	3/4" BACK FLOW PREVENTER	BRASS		P62-1918
17	3/4" MIXING VALVE FLAPPER CXC	*		P68-2831
18	3/8" FILL PIPE WITH FLANGE	*		*
19	3/4" FILL PIPE WITH FLANGE & UNION			A10-6648
20	STERO STRIGHT WATER TOWER WITH UNION			B10-2678
21	2 GPM FLOW RESTRICTOR			P68-1175
	3 GPM FLOW RESTRICTOR			P68-1176
	4 GPM FLOW RESTRICTOR			P68-1673

\* TO ORDER SUPPLY MACHINE MODEL AND SERIAL NUMBER

( 102 )

# 1/2" COPPER & BRASS FITTINGS

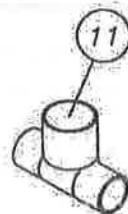
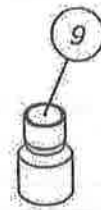
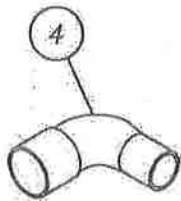
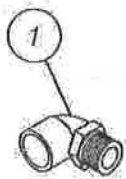





# 3/4" COPPER & BRASS FITTINGS

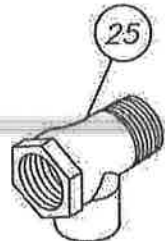
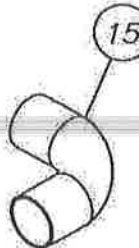
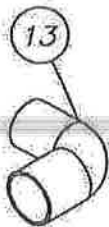
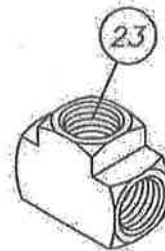
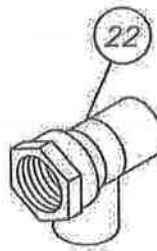
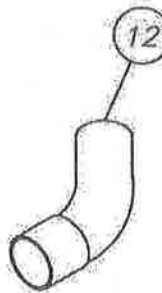
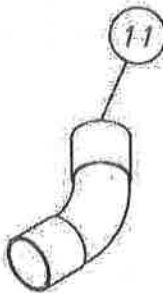
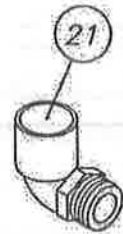
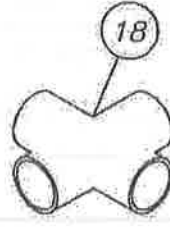
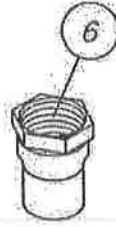
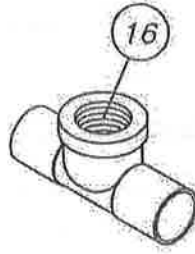
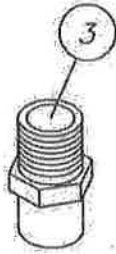
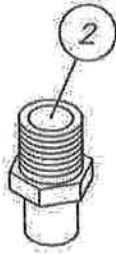

### 3/4" COPPER & BRASS FITTINGS

ITEM	DESCRIPTION	REMARKS	REQ.	PART NO.
1	ADAPTOR 3/4" X 1/2" CXM	COPPER		P68-1434
2	ADAPTOR 3/4" FTGXM	COPPER		P68-1431
3	ADAPTOR 3/4" CXM	COPPER		P68-1430
4	ADAPTOR 3/4" X 1/2" FTGXM	COPPER		P68-1435
5	ADAPTOR 3/4" FTGXF	COPPER		P68-1433
6	ADAPTOR 3/4" CXF	COPPER		P68-1432
7	ADAPTOR 3/4" X 1/2" FTGXF	COPPER		P68-1437
8	ADAPTOR 3/4" X 1/2" CXF	COPPER		P68-1436
9	UNION 3/4" CXC	COPPER		P68-1446
10	ELBOW 90 3/4" FTGXC CLOSE STREET SHORT	COPPER		P68-1441
11	ELBOW 45 3/4" CXC	COPPER		P68-1438
12	ELBOW 45 3/4" FTGXC	COPPER		P68-1439
13	ELBOW 90 3/4" CXC SHORT	COPPER		P68-1440
14	TEE 3/4" CXCXC	COPPER		P68-1447
15	ELBOW 90 3/4" CXC LONG	COPPER		P68-1442
16	TEE 3/4" X 3/4" X 3/4" CXCXF CAST	BRASS		P68-1448
17	TEE 3/4" X 3/4" X 1/2" CXCXF CAST	BRASS		P68-1449
18	CROSS 3/4" CXCXCXC CAST	BRASS		P68-6544
19	TEE 3/4" X 1/2" X 3/4" CXFXC CAST	BRASS		P68-1429
20	ELBOW 90 3/4" CXM CAST	BRASS		P68-1466
21	ELBOW 90 3/4" X 1/2" CXM SHORT	BRASS		P68-1462
22	TEE 3/4" X 3/4" X 3/4" CXFXC	BRASS		P68-1458
23	TEE 3/4" X 3/4" X 3/4" FIP	BRASS		P68-1455
24	ELBOW 90 3/4" X 1/2" CXF CAST	BRASS		P68-1461

\* TO ORDER SUPPLY MACHINE MODEL AND SERIAL NUMBER

# ASSORTED BRASS FITTINGS

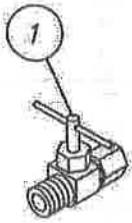



# DRAIN & OVERFLOW ASSEMBLY

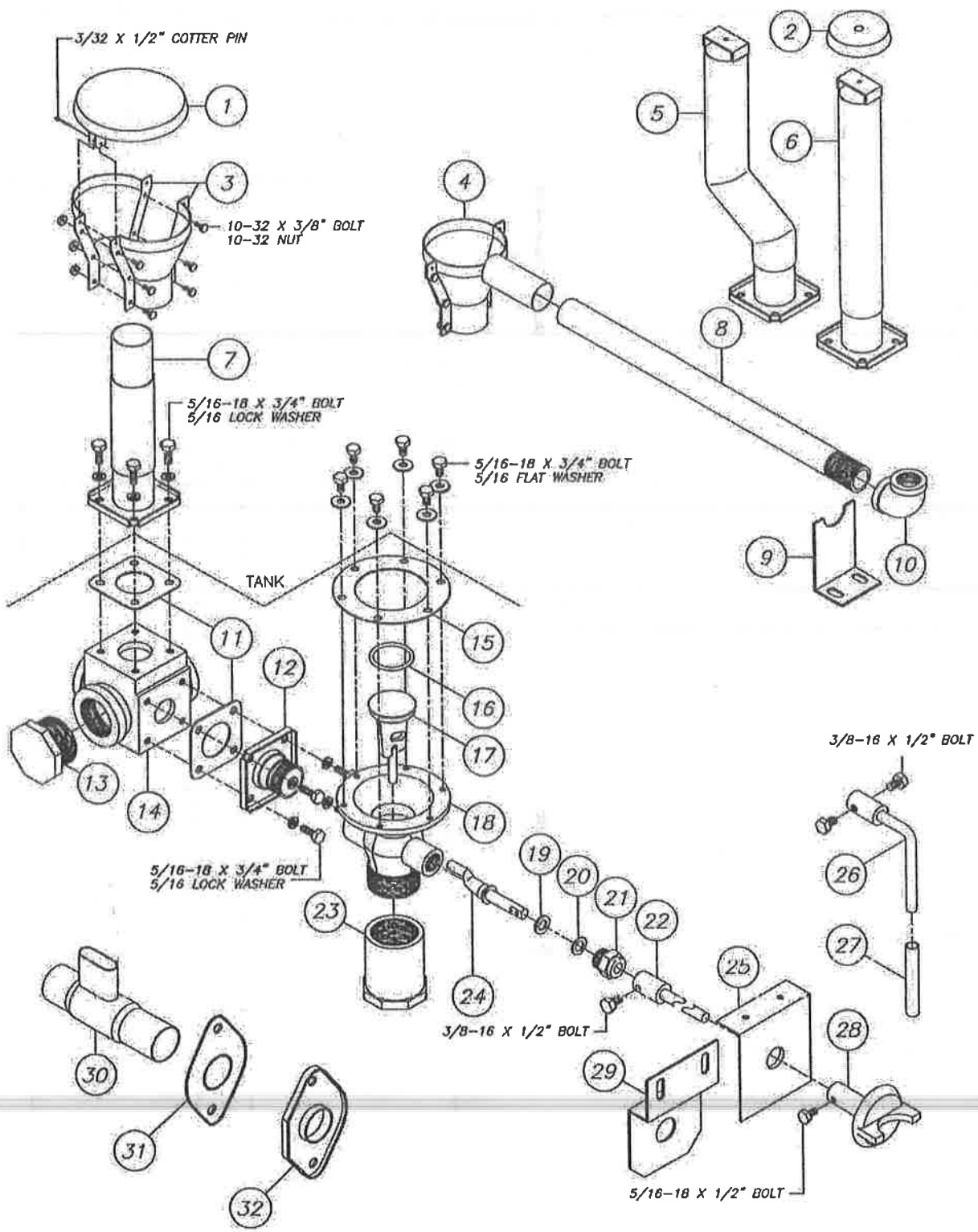

## DRAIN & OVERFLOW ASSEMBLY

ITEM	DESCRIPTION	REMARKS	REQ.	PART NO.
1	FUNNEL COVER			A10-1874
2	CAP, OVERFLOW TUBE			A10-1508
3	FUNNEL OVERFLOW ASSM. (PART #			A10-1873
	INCLUDES BOTH HALVES & HARDWARE			
4	FUNNEL OVERFLOW WITH SIDE OUTLET			B10-2446
5	ANGLED OVERFLOW STAND PIPE			A10-2158
6	OVERFLOW SCRAP TANK STAND PIPE			*A10-2273
7	OVERFLOW STAND PIPE TO FUNNEL			A10-1889
8	PIPE, FINAL RINSE OVERFLOW 16-1/2"			A10-3698
9	BRACKET, FINAL RINSE OVERFLOW PIPE			A10-3699
10	ELBOW 90° 1" BRASS FIP			P68-1422
11	GASKET "U"	2 REQ'D		A57-1114
12	ADAPTOR ASSM. DRAIN TO OVERFLOW			A10-3305
13	PVC PLUG 2"; OVERFLOW			P68-1698
14	TEE OVERFLOW DRAIN BOX #97			B10-1871
15	GASKET "D" WASTE VALVE FLANGE			A57-1194
16	ORING #327 VITON; FOR DRAIN VALVE POPPET			P57-1057
17	DRAIN VALVE POPPET WITH ORING			A44-1196
18	WASTE VAVLE BODY			C10-1193
19	PACKING RING; DRAIN VALVE			P57-6253
20	PACKING WASHER BRASS; DRAIN VALVE			A10-1183
	PACKING WASHER & RING KIT	INCLUDES 19 & 20		A10-6254
21	PACKING NUT BRASS; DRAIN VALVE			A10-1182
22	SHAFT, CROSS OVER 11-3/4" LG.			B10-2068
	SHAFT, CROSS OVER 12-1/2" LG.			B10-2909
	SHAFT, CROSS OVER 19-1/8" LG.			B10-2069
23	PVC CAP 2"; DRAIN VALVE			A10-2067
24	ECCENTRIC ARM; DRAIN VALVE			A10-1184
25	PLATE GUIDE SCRAPPER DRAIN VALVE			A10-2282
26	HANDLE; DRAIN VALVE			A10-4732
27	SLEEVE-BLUE; DRAIN VALVE HANDLE			P57-2826
28	HANDLE; DRAIN VALVE #98			B10-1888
29	BRACKET, DRAIN VALVE HANDLE			B10-1927
30	TEE WASH OVERFLOW 2" PIPE			B10-2274
	TEE WASH OVERFLOW 1-5/8" PIPE			B10-2274A
31	PIPE FLANGE GASKET			B57-2444
32	PIPE FLANGE ADAPTER 1-5/8" HOLE			B10-3362
	PIPE FLANGE ADAPTER 2" HOLE			B10-1506
	PIPE FLANGE ADAPTER 2-1/8" HOLE			B10-3361
	OVERFLOW DRAIN TEE ASSEMBLY			A10-1875
	(INCLUDES ITEMS 1,3,7,11,12, & 14)			
	DRAIN VALVE COMPLETE ASSEMBLY			A10-1251
	(INCLUDES ITEMS 16 THRU 21 & 24)			
	WASTE VALVE COMPLETE ASSEMBLY			A10-5265
	(INCLUDES ITEMS 11, 12, 14 & 16 THRU 21)			

\* TO ORDER SUPPLY MACHINE MODEL AND SERIAL NUMBER

( 110 )

# TEMP. & PRESSURE GAUGE ASSEMBLY

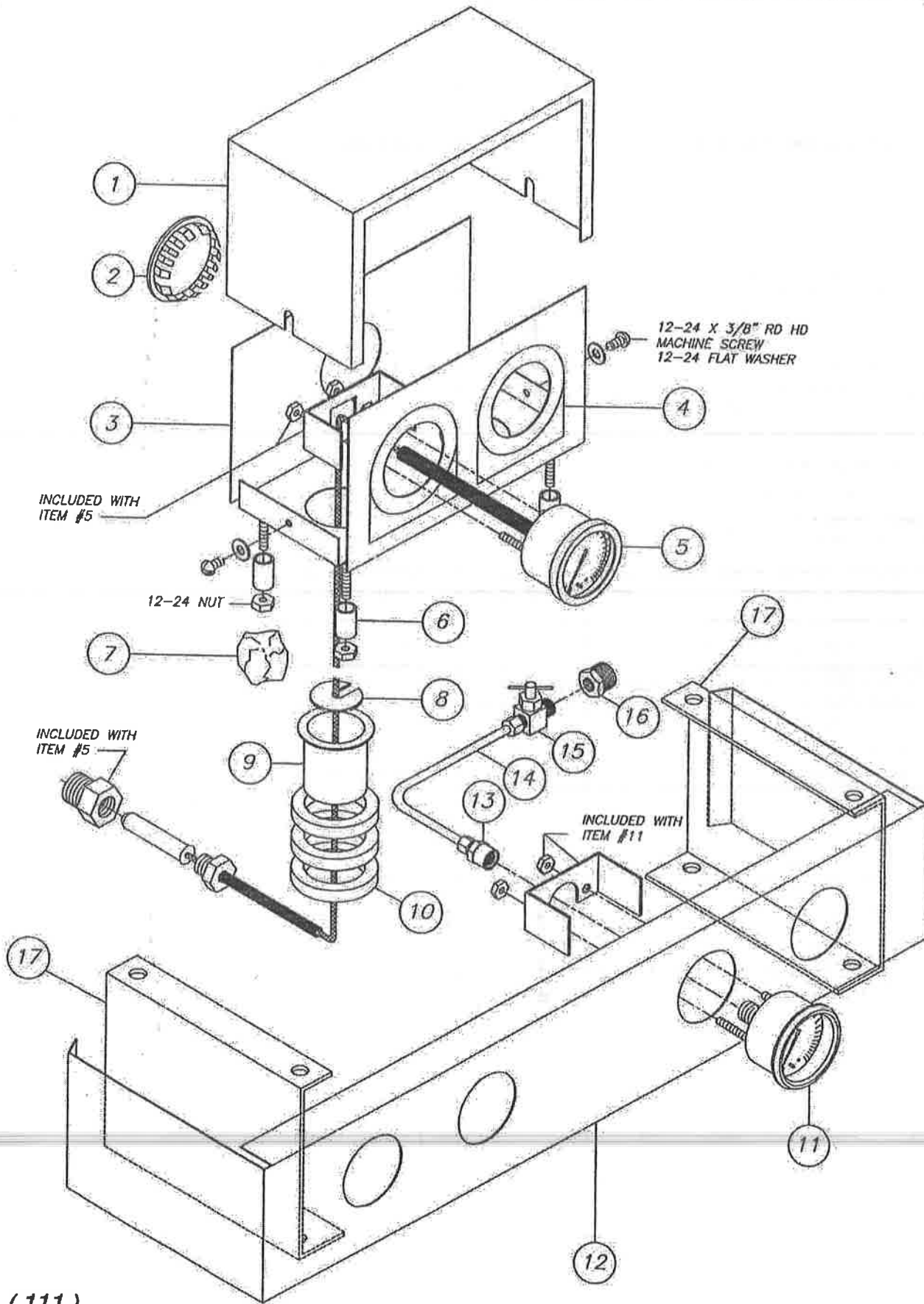



## TEMP. & PRESSURE GAUGE ASSEMBLY

ITEM	DESCRIPTION	REMARKS	REQ.	PART NO.
1	COVER GAUGE BOX			B10-2148
2	PLUG CAP 2" CHROME PLATED			P67-2619
3	HOUSING ASSM. TWIN TEMP. GAUGE			B10-2149
4	DECAL TEMP. GAUGE POWER SCAPPER	110-140		A69-1454
	DECAL TEMP. GAUGE PRIMARY RINSE	140-160		A69-1455
	DECAL TEMP. GAUGE POWER WASH	150-165		A69-1456
	DECAL TEMP. GAUGE POWER WASH	160-175		A69-1457
	DECAL TEMP. GAUGE POWER WASH	140-160		A69-1458
	DECAL TEMP. GAUGE POWER RINSE	160-190		A69-1459
	DECAL TEMP. GAUGE FINAL RINSE	180-200		A69-1460
	DECAL TEMP. GAUGE SANITIZING RINSE	140-160		A69-1461
	DECAL TEMP. GAUGE LO TEMP RINSE	120-150		A69-2304
	DECAL TEMP. GAUGE AUX. RINSE TANK	165-170		A69-6328
5	TEMPERATURE GAUGE			P65-1135
	TEMPERATURE GAUGE WITH 8' LONG LEAD			P65-5948
	PROBE EXTENSION 1/2" MXF	NOT SHOWN		P68-2869
6	SPACER STAND-OFF LEGS	4 REQ'D		A10-2070
7	SEALING PUTTY (DUM-DUM)			P57-1878
8	WASHER SEALING CUP			A10-2155
9	CUP SEALING FOR GAUGE			A10-2150
10	RINGS, NEOPREME	3 REQ'D		A57-2156
11	PRESSURE GUAGE 100 LBS. 1/4" BACK CON.			P65-2228
12	DASHBOARD 4 HOLE			B10-2725
13	COMP/FIT STR. 1/4 X 1/4			P68-1509
14	1/4" COPPER TUBING			
15	NEEDLE VALVE 1/4 MIP-FIP STRIAGHT			P68-1511
16	1/2" X 1/4" BRASS REDUCING BUSHING			P68-1534
17	MOUNTING BRACKET			A10-2705
	SINGLE HOLE TEMP GAUGE BRACKET			A10-1604

\* TO ORDER SUPPLY MACHINE MODEL AND SERIAL NUMBER

( 112 )

# PRINTED CIRCUIT CONTROL PANEL PARTS

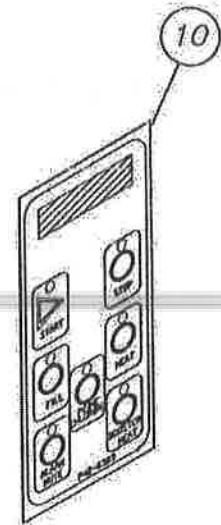
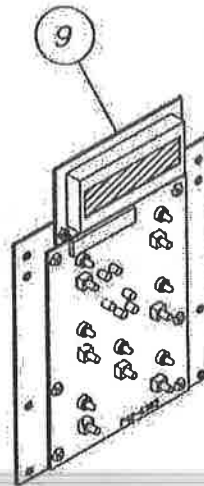
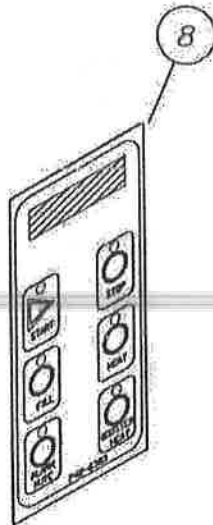
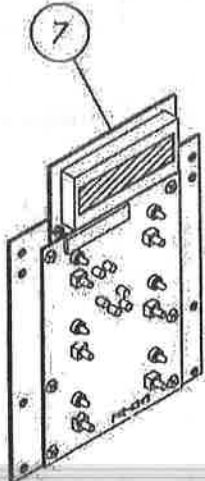
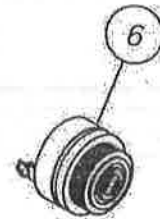
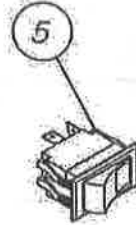
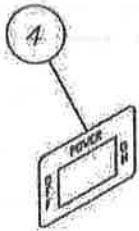
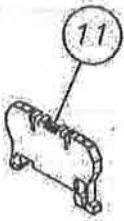
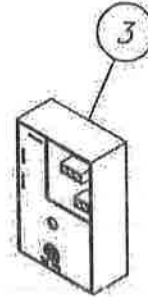
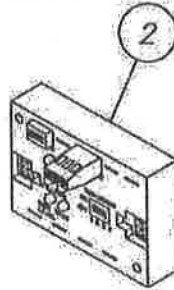
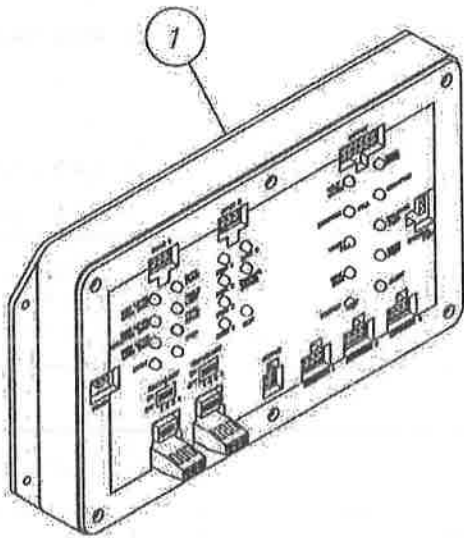



# CONTROL BOXES

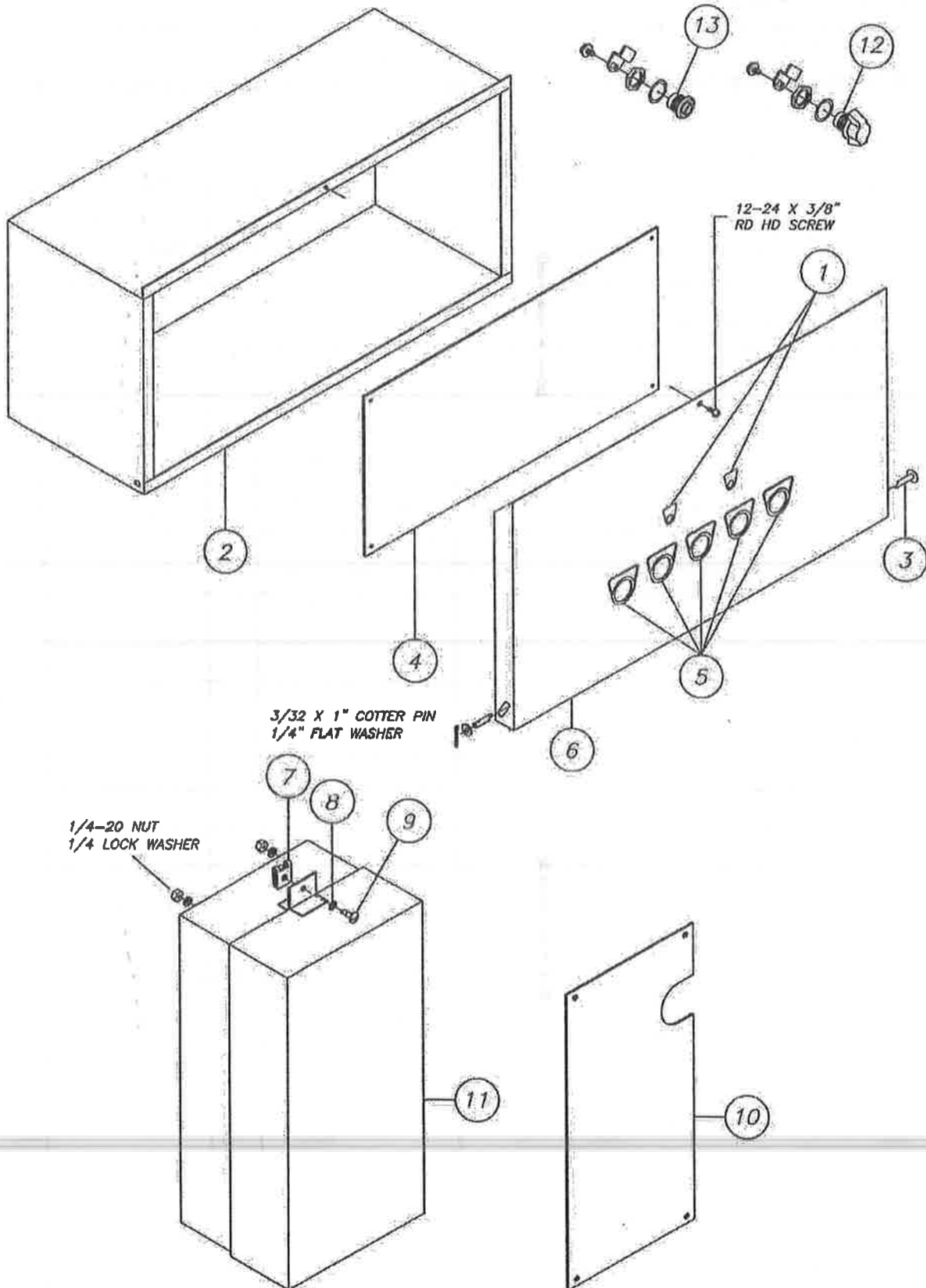

## CONTROL BOXES

ITEM	DESCRIPTION	REMARKS	REQ.	PART NO.
1	DECAL, BURNER (INFRARED MACHINE)			A69-5800
	DECAL, BLOWER (INFRARED MACHINE)			A69-5799
2	CONTROL BOX STANDARD 22"	S# REQ'D		B10-2100
3	ROD PIVOT PIN, CONTROL BOX DOOR			A10-2114
4	BASE PLATE (SPECIFY SIZE)			*
5	SAFETY ON/OFF (DECAL)			A69-4148
	TANK FILL ON/OFF (DECAL)			A69-4144
	FILL (DECAL)			A69-4139
	TANK HEAT ON/OFF (DECAL)			A69-4147
	TANK HEAT (DECAL)			A69-4315
	WASH HEAT (DECAL)			A69-4316
	RINSE HEAT (DECAL)			A69-4140
	BOOSTER (DECAL)			A69-4141
	BOOSTER ON/OFF (DECAL)			A69-4143
	START (DECAL)			A69-4138
	STOP (DECAL)			A69-4138
	START PUMP (DECAL)			A69-4313
	STOP PUMP (DECAL)			A69-4314
	START CONVEYOR (DECAL)			A69-4149
	STOP CONVEYOR (DECAL)			A69-4150
	RUN PILOT (DECAL)			A69-4317
	RESET (DECAL)			A69-5833
6	CONTROL PANEL DOOR WITH 3 SWITCH HOLES	S# REQ'D		A10-3762
	CONTROL PANEL DOOR WITH 4 SWITCH HOLES	S# REQ'D		A10-3764
	CONTROL PANEL DOOR WITH 5 SWITCH HOLES	S# REQ'D		A10-3765
	CONTROL PANEL DOOR WITH 6 SWITCH HOLES	S# REQ'D		A10-3766
	CONTROL PANEL DOOR WITH 3 SWITCH HOLES & CHEMICAL PUMP HOLES	S# REQ'D		A10-5284
7	LATCH			P69-5783
8	WASHER			P69-5785
9	PIN			P69-5784
10	MOUNTING PLATE FOR SMALL CONTROL BOX.	S# REQ'D		A10-2482
	MOUNTING PLATE FOR LARGE CONTROL BOX.	S# REQ'D		A10-2485
11	SIDE MOUNTED CONTROL BOX SMALL	S# REQ'D		C48-1314
	SIDE MOUNTED CONTROL BOX LARGE	S# REQ'D		C48-1315
12	LATCH WINGED			P69-6678
13	LATCH SLOTTED			P69-6679

\* TO ORDER SUPPLY MACHINE MODEL AND SERIAL NUMBER

( 116 )

# SWITCH ASSEMBLIES

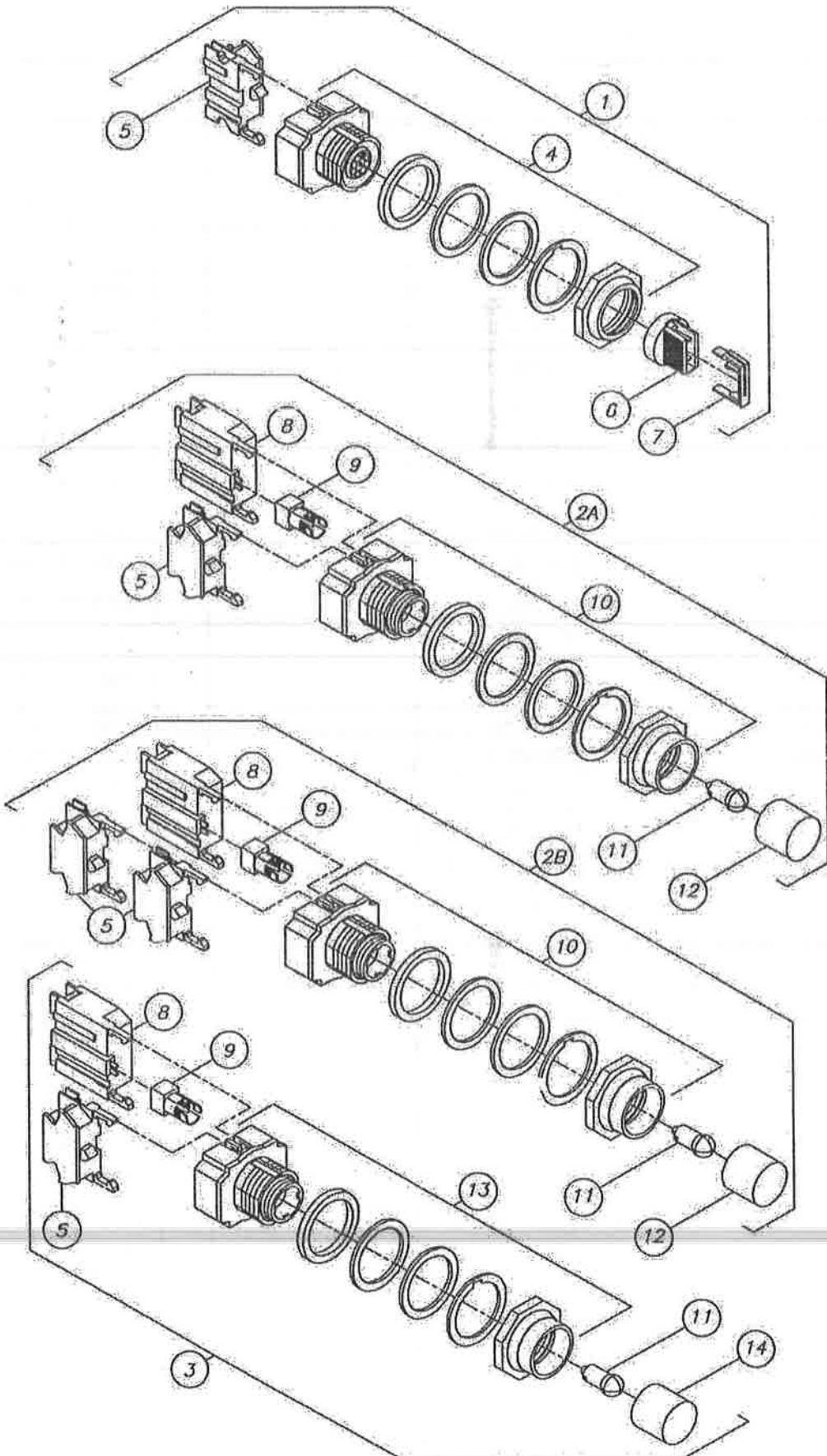



# SWITCH ASSEMBLIES

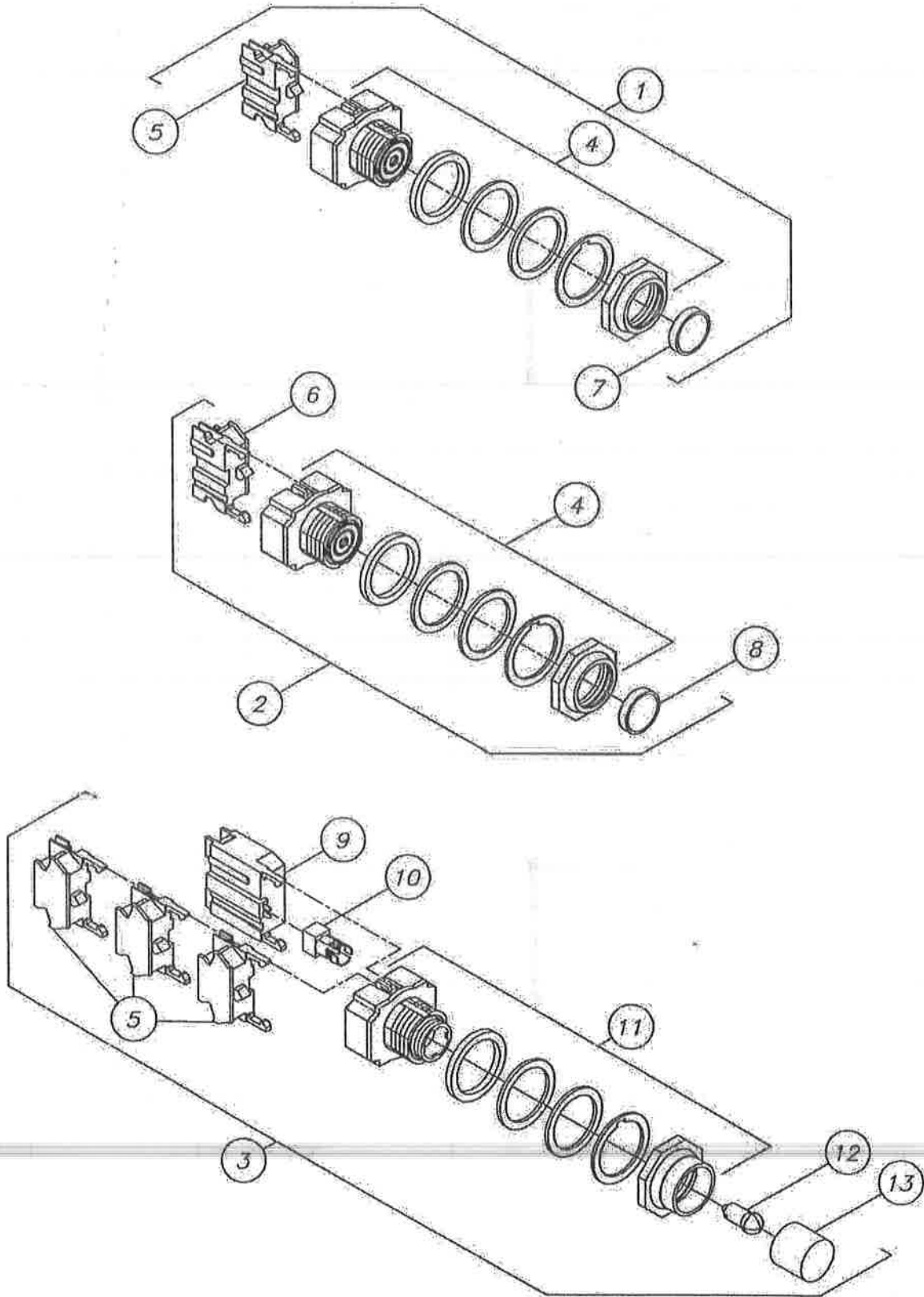



## SWITCH ASSEMBLIES

ITEM	DESCRIPTION	REMARKS	REQ.	PART NO.
1	SWITCH START OR RESET COMP. ASSM.			A10-1936
2	SWITCH STOP COMP. ASSM.			A10-1937
3	SWITCH FILL COMP. ASSM. (3 TANK MACHINE)	SPEC. VOLTS		A10-3734
4	PUSH BUTTON OPERATOR			P49-1305
5	N/O A BLOCK	(GREEN)		P49-1303
6	N/C B BLOCK	(RED)		P49-1304
7	BLACK DISC CAP			P49-1314
8	RED DISC CAP			P49-1315
9	TRANSFORMER 110 VOLT TO 6.3 VOLT			P49-1301
	TRANSFORMER 220 VOLT TO 6.3 VOLT			P49-1302
10	LAMP HOLDER SHORT			P49-1319
11	PUSH BUTTON ILLUMINATED MOMENTARY			P49-1310
12	LAMP #51			P49-1322
13	RED LENS			P49-1311

\* TO ORDER SUPPLY MACHINE MODEL AND SERIAL NUMBER

# CONTROL BOX COMPONENTS

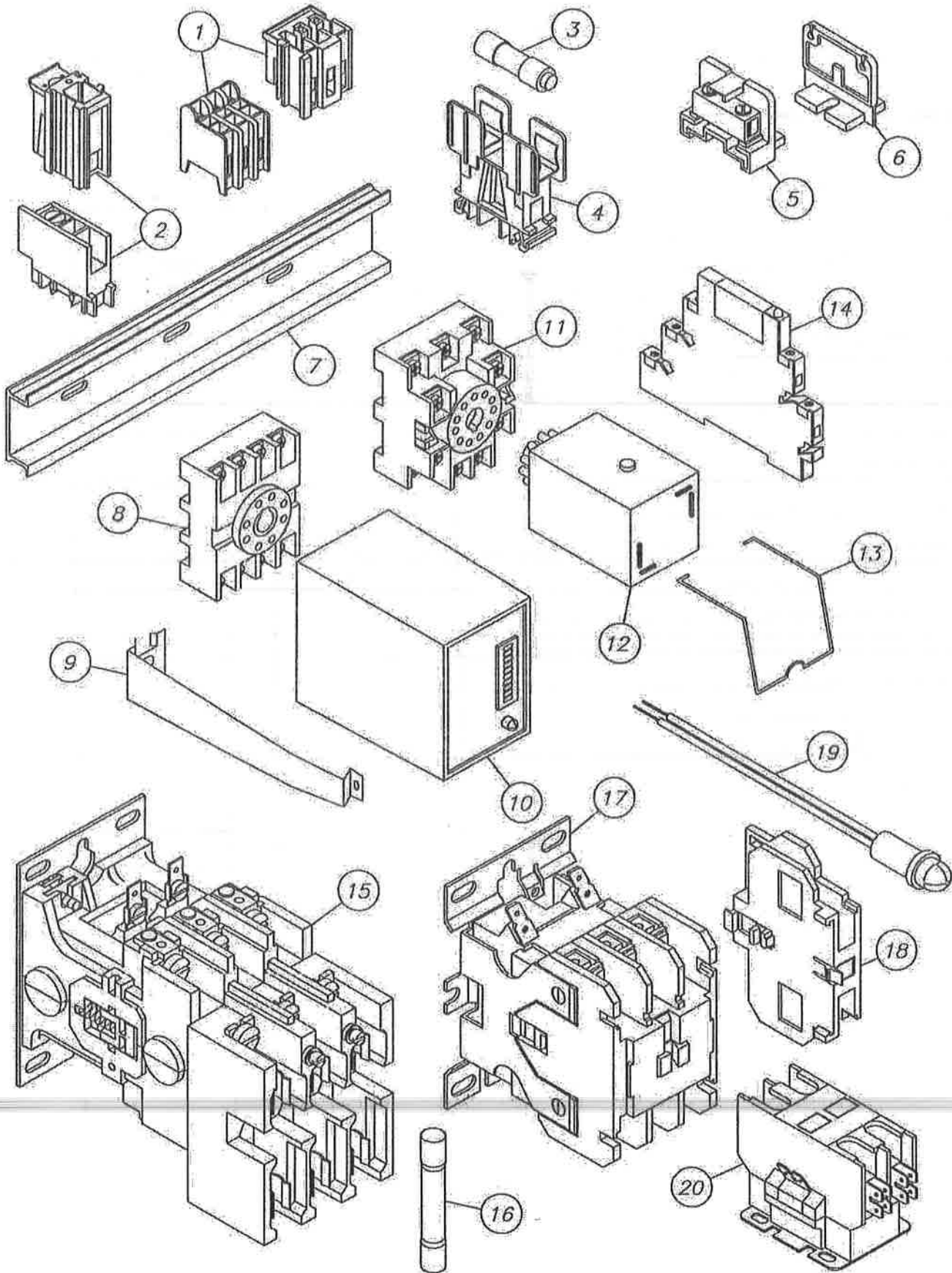

## CONTROL BOX COMPONENTS

ITEM	DESCRIPTION	REMARKS	REQ.	PART NO.
1	LARGE SINGLE POLE PULL-AWAY	WHITE		P52-6237
2	SMALL THREE POLE PULL-AWAY	WHITE		P52-6235
3	FUSE KLKR 3 AMP MAX 600V CLASS CC			P52-1854
	FUSE KLKR 5 AMP MAX 600V CLASS CC			P52-2192
	FUSE KLKR 10 AMP MAX 600V CLASS CC			P52-1855
	FUSE KLKR 20 AMP MAX 600V CLASS CC			P52-1856
	FUSE KLKR 30 AMP MAX 600V CLASS CC			P52-1857
4	DIM RAIL MOUNTED FUSE HOLDER			P52-5996
5	TERMINAL BLOCK SMALL #524	GRAY		P52-1099
	TERMINAL BLOCK LARGE #222	WHITE		P52-1868
6	TERMINAL BLOCK END SECTION SMALL #530	GRAY		P52-1100
	TERMINAL BLOCK END SECTION LARGE #230	WHITE		P52-1869
7	DIM RAIL (SPECIFY LENGTH)			P47-1787
8	TIMER SOCKET	8 PIN		P47-6352
9	TIMER HOLD DOWN CLIP			A10-3275
10	ADJUSTABLE SHUT-DOWN TIMER 115V.	8 PIN		P46-1744
	ADJUSTABLE SHUT-DOWN TIMER 240V.	8 PIN		P46-1745
11	RELAY SOCKET	11 PIN		P47-2465
12	RELAY 3 POLE 10 AMP 115V.	11 PIN		P47-2464
	RELAY 3 POLE 10 AMP 240V.	11 PIN		P47-2463
13	RELAY HOLD DOWN CLIP			P47-2466
14	SPDT RELAY 6 AMP 125V. #8262T12	BLUE		P47-5704
	SPDT RELAY 6 AMP 240V. #8262T13	BLUE		P47-6705
15	FUSIBLE CONTACTOR 2 POLE 120V 30 AMP			P47-1819
	FUSIBLE CONTACTOR 2 POLE 240V 30 AMP			P47-1820
	FUSIBLE CONTACTOR 3 POLE 120V 40 AMP			P47-1821
	FUSIBLE CONTACTOR 3 POLE 240V 40 AMP			P47-1822
	FUSIBLE CONTACTOR 3 POLE 120V 60 AMP			P47-1823
	FUSIBLE CONTACTOR 3 POLE 240V 60 AMP			P47-1824
16	FUSE SLC 25 AMP CLASS G	TIME-DELAY		P52-1746
	FUSE SLC 30 AMP CLASS G	TIME-DELAY		P52-1747
	FUSE SLC 35 AMP CLASS G	TIME-DELAY		P52-1748
	FUSE SLC 40 AMP CLASS G	TIME-DELAY		P52-5843
	FUSE SLC 50 AMP CLASS G	TIME-DELAY		P52-6392
	FUSE SLC 60 AMP CLASS G	TIME-DELAY		P52-1749
17	CONTACTOR 3 POLE 115V. 25/35 AMP			P47-5494
	CONTACTOR 3 POLE 220V. 25/35 AMP			P47-5496
	CONTACTOR 3 POLE 115V. 30/40 AMP			P47-5500
	CONTACTOR 3 POLE 220V. 30/40 AMP			P47-5502
	CONTACTOR 3 POLE 115V. 40/50 AMP			P47-5504
	CONTACTOR 3 POLE 220V. 40/50 AMP			P47-5506
	CONTACTOR 3 POLE 115V. 50/65 AMP			P47-6207
	CONTACTOR 3 POLE 220V. 50/65 AMP			P47-5511
18	AUXILIARY CONTACTOR 1 N/O			P47-5517
	AUXILIARY CONTACTOR 2 N/O			P47-5718
	AUXILIARY CONTACTOR 2 N/C			P47-5989
	AUXILIARY CONTACTOR 1 N/O - 1 N/C			P47-5508
19	PILOT LIGHT 115V. RED			P49-5788
	PILOT LIGHT 240V. RED			P49-5789
20	CONTACTOR 2 POLE 115V. 20/30 AMP	EXHAUST FAN		P47-6044
	CONTACTOR 2 POLE 240V. 20/30 AMP	EXHAUST FAN		P47-5708
	WIRE 10086B-12112 UL/CSA BLK			P45-2175
	WIRE 8 STRANDED THHN BLK			P45-2182
	WIRE 6 STRANDED THHN BLK			P45-2183
	CONTACTOR 3 POLE/1AUX MINI 20AMP 240V			P47-6399

\* TO ORDER SUPPLY MACHINE MODEL AND SERIAL NUMBER

( 122 )

# CIRCUIT BREAKERS & DISTRIBUTION BLOCKS

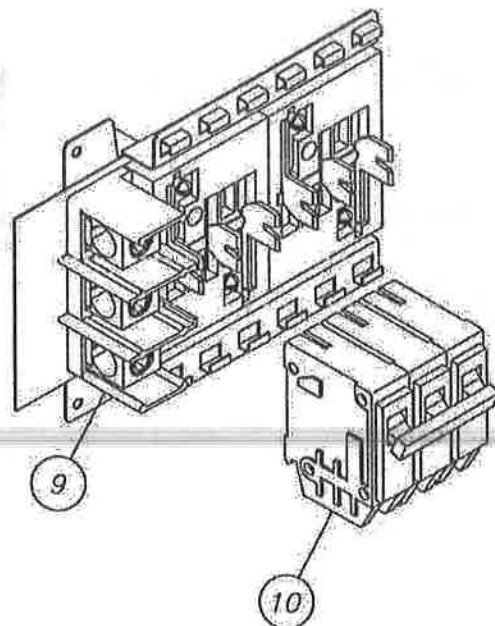
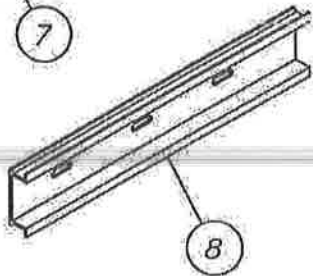
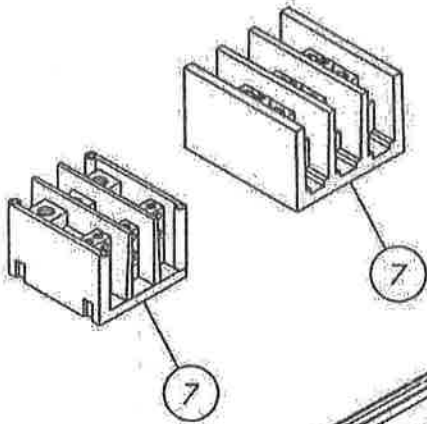
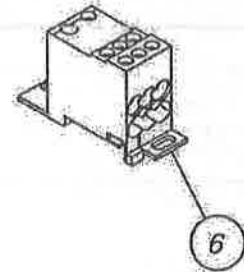
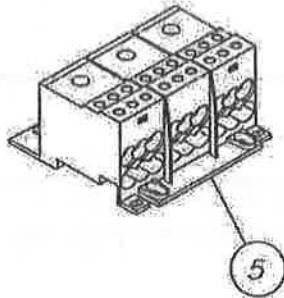
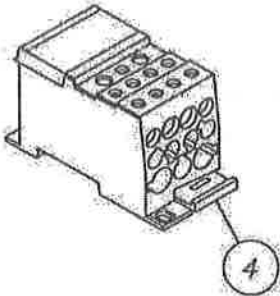
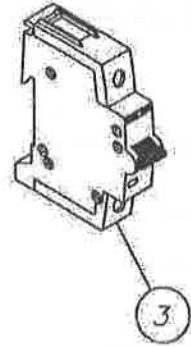
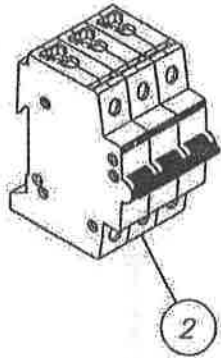
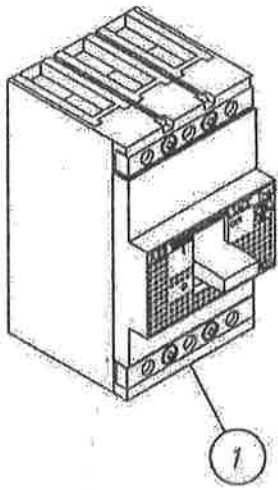

## CIRCUIT BREAKERS & DISTRIBUTION BLOCKS

ITEM	DESCRIPTION	REMARKS	REQ.	PART NO.
1	15 AMP 3 POLE 480V. ABB			P48-6261
	20 AMP 3 POLE 480V. ABB			P48-6262
	30 AMP 3 POLE 480V. ABB			P48-6263
	40 AMP 3 POLE 480V. ABB			P48-6264
	50 AMP 3 POLE 480V. ABB			P48-6265
	60 AMP 3 POLE 480V. ABB			P48-6266
	70 AMP 3 POLE 480V. ABB			P48-6267
	90 AMP 3 POLE 480V. ABB			P48-6268
	100 AMP 3 POLE 480V. ABB			P48-6269
	125 AMP 3 POLE 480V. ABB			P48-6270
2	16 AMP 3 POLE 240V. ABB			P48-6089
	20 AMP 3 POLE 240V. ABB			P48-6090
	63 AMP 3 POLE 240V. ABB			P48-6092
3	16 AMP 1 POLE 240V. ABB			P48-6194
	<i>"DISTRIBUTION BLOCKS"</i>			
4	400 AMP 9 HOLE DIST. BLOCK	WHITE		P52-6281
	250 AMP 9 HOLE DIST. BLOCK	"		P52-6430
5	175 AMP 6 HOLE DIST. BLOCK	GREY/RED		P52-6316
6	125 AMP 6 HOLE DIST. BLOCK	"		P52-6294
7	90 AMP 1 IN 4 OUT DIST. BLOCK	BLACK		P52-5709
	90 AMP 1 IN 1 OUT DIST. BLOCK	"		P52-5777
8	DIM RAIL ( SPECIFY LENGTH )			P47-1787
	DIM RAIL STOP			P47-6299
9	OLDER STYLE CIRCUIT BREAKER SADDLES ( CALL FACTORY WITH THE AMOUNT OF CIRCUITS AND BRAND OF BREAKERS )			*
10	OLDER STYLE CIRCUIT BREAKERS ( CALL FACTORY WITH THE BRAND NAME OF BREAKER NUMBER OF POLES AND AMPERAGE REQUIRED )			*
	" BREAKER ENCLOSURE PANELS NOT SHOWN " ( FOR CIRCUIT BREAKER ENCLOSURE PANELS CALL FACTORY WITH MODEL & SERIAL NO. )			*

\* TO ORDER SUPPLY MACHINE MODEL AND SERIAL NUMBER

# PRINTED CIRCUIT CONTROL PANEL WIRING HARNESS'S

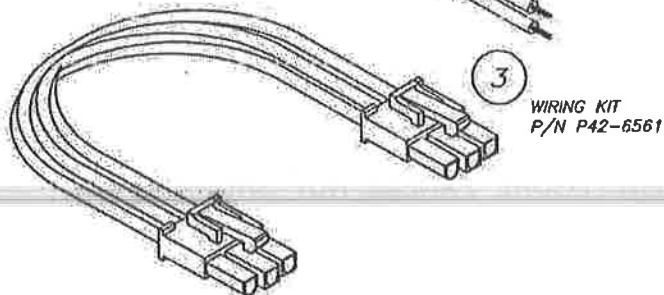
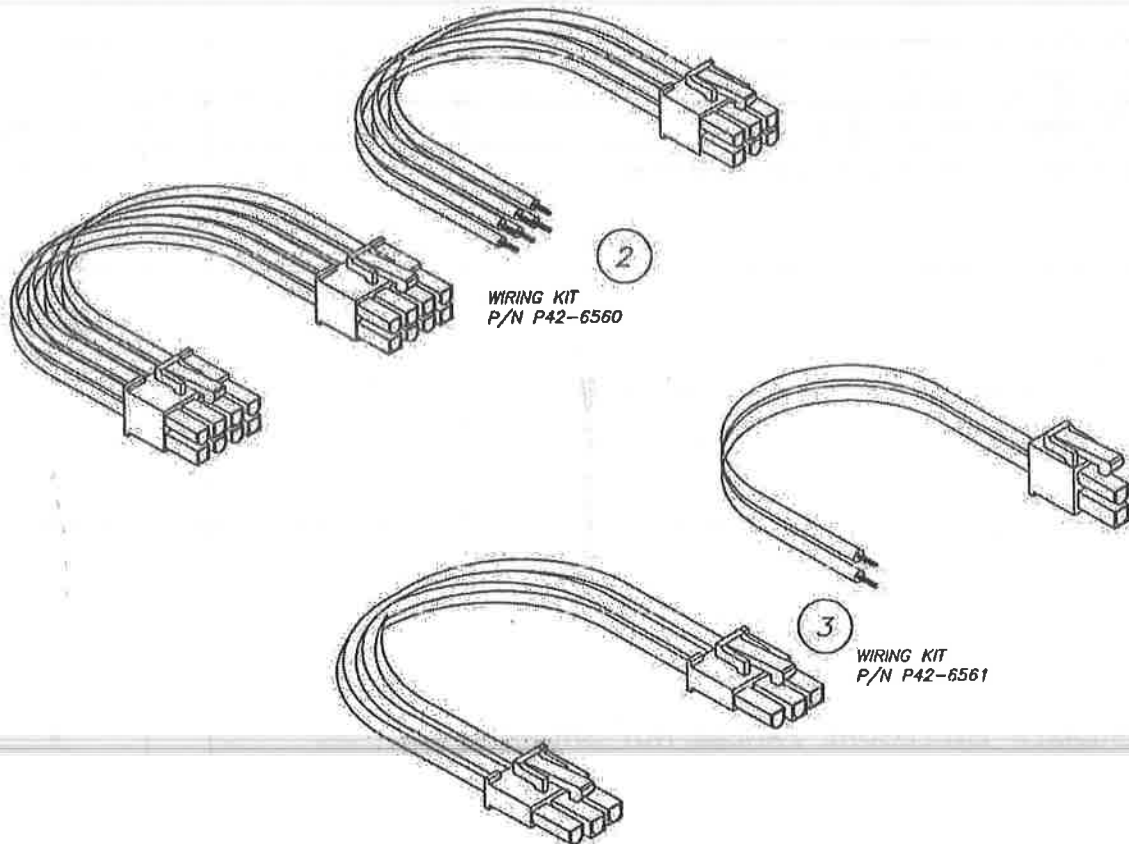
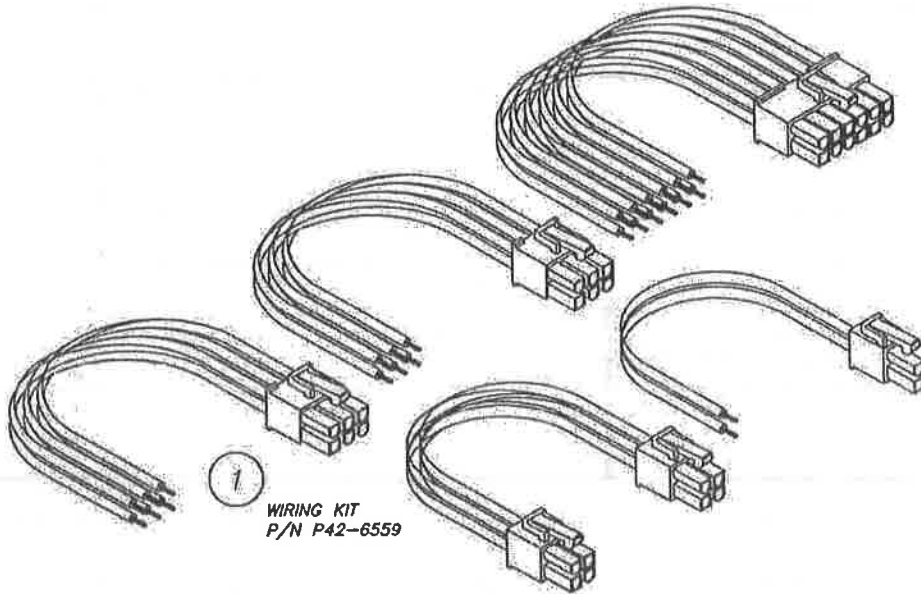



# TABLE LIMIT SWITCH ASSEMBLY

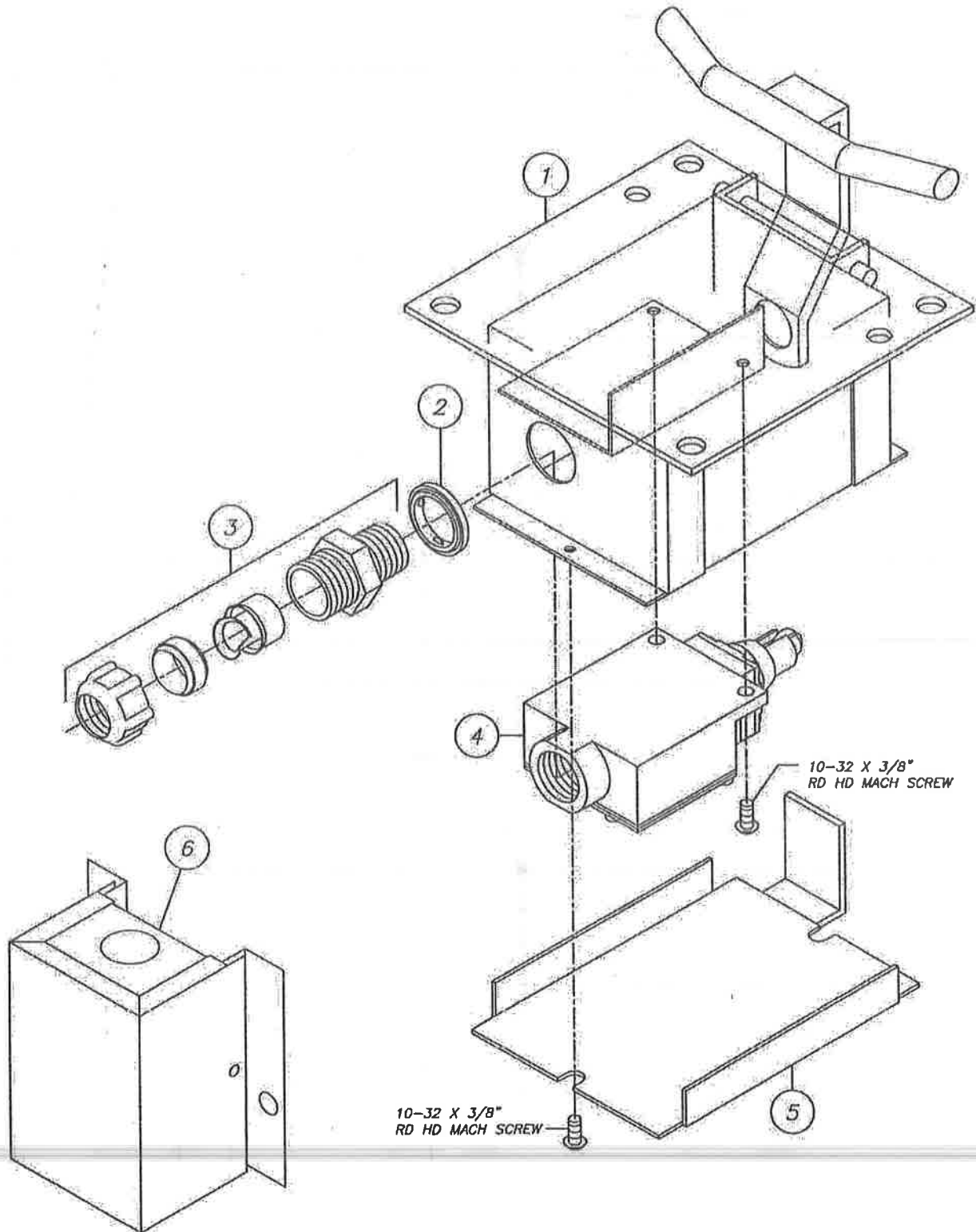





# ASSEMBLY, FLOAT SWITCH - C10-1005

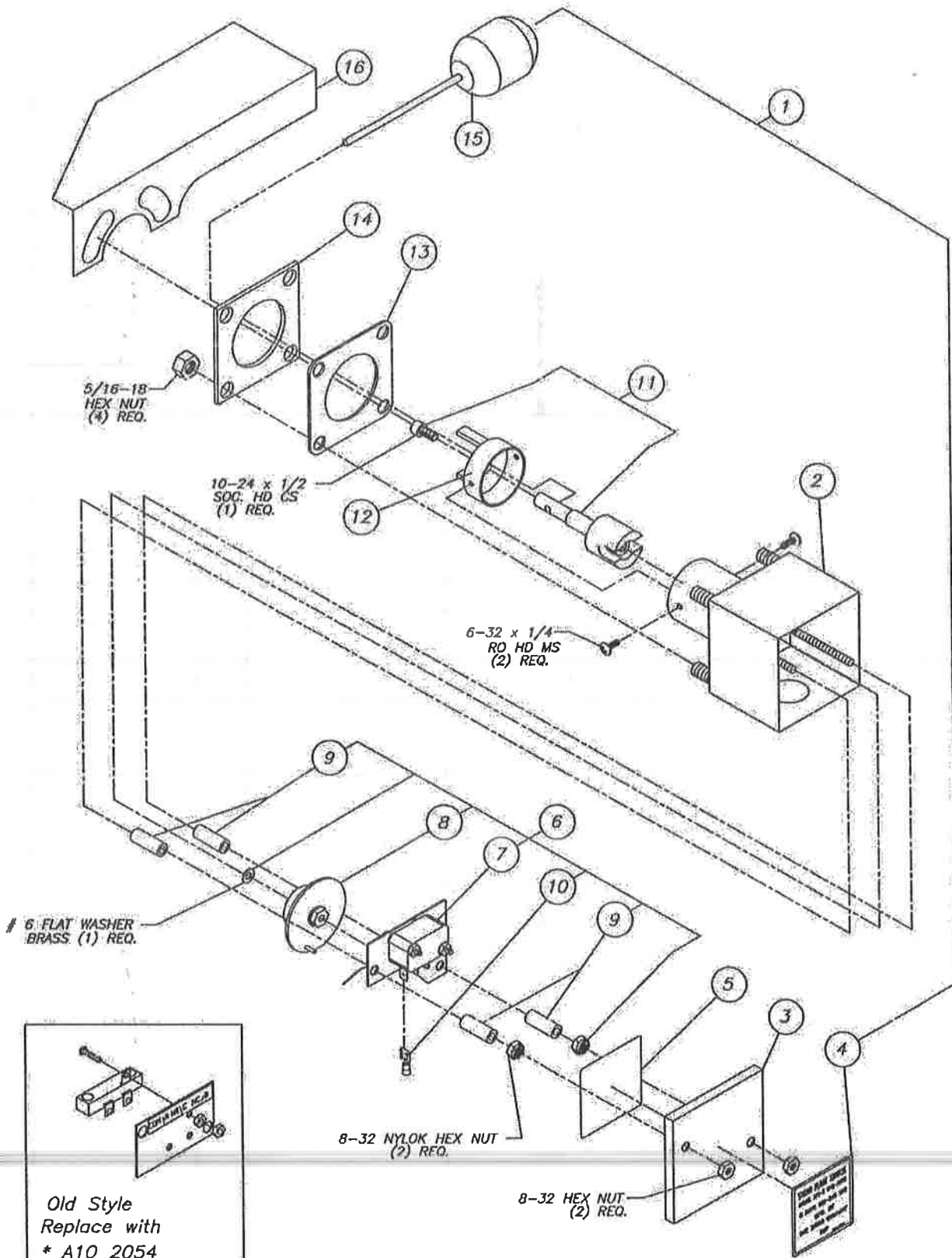

## ASSEMBLY, FLOAT SWITCH - C10-1005

ITEM	DESCRIPTION	REMARKS	REQ.	PART NO.
1	ASSBLY, FLOAT SWITCH COMPLETE	INCLUDES-2 THRU 15		C10-1005
2	ASSBLY, HOUSING [ BOX ]			B10-1423
3	COVER, SWITCH BOX			A10-1424
4	DECAL, "STERO FLOAT SWITCH"	OUTER		A69-1954
5	DECAL, "SWITCH CONNECTIONS"	INNER		A69-5329
6	ASSBLY, MICRO SWITCH	INCLUDES-7 THRU 10		A10-2054
7	SWITCH, MICRO	ORDER A10-2054		P49-1113
8	ASSBLY, MAGNET/DISK			A10-4484
9	SPACER, MICRO SWITCH MNTG PLATE	RED PLASTIC		A59-6341
10	TERMINAL, WIRE-FEMALE SLIP	WIRE CRIMP		A52-5181
11	ASSBLY, MAGNET/SHAFT			A10-4485
12	ASSBLY, FLOAT SWITCH MAGNET COVER/STOP			A10-1431
13	GASKET, FLOAT SWITCH MNTG.			A10-1419
14	PLATE, FLOAT SWITCH MNTG.			A10-1418
15	FLOAT, [ BALL WITH SHAFT ]			A10-1432
16	SHIELD, FLOAT GUARD			B10-2059
	ASSBLY, MICRO SWITCH	OLD STYLE		NLA

# LARGE FLOAT "THE BIG BOBBER"

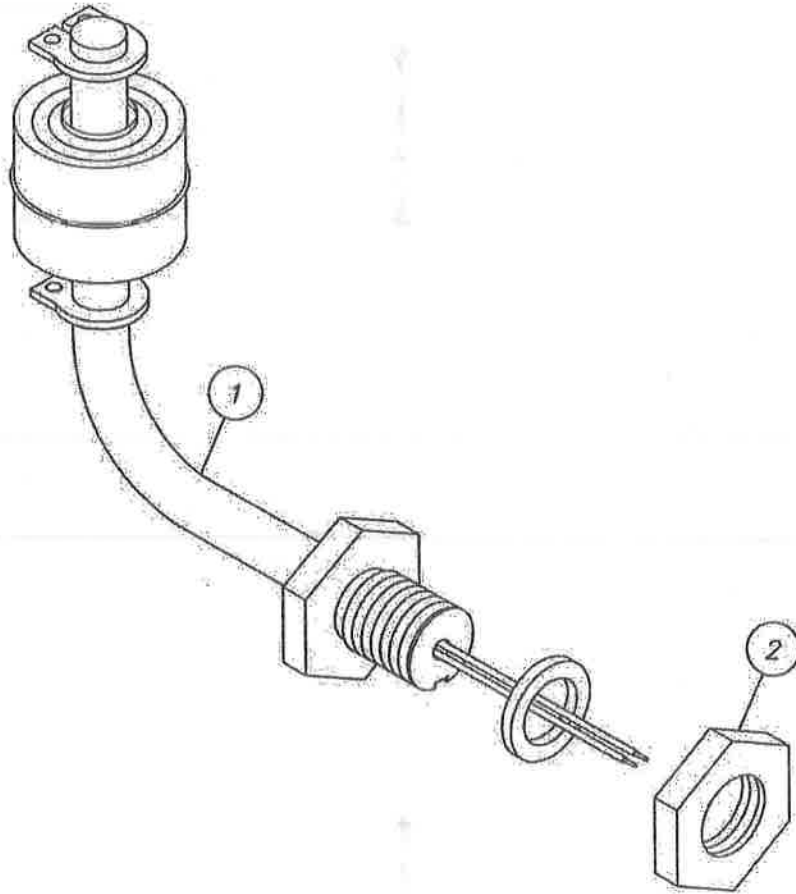



# MADISON FLOAT SWITCH ASSEMBLY

**ATTENTION:**  
CHECK POSITION OF TRIANGLE OR  
CIRCLE ON FLOAT WHEN INSTALLING.



"NORMALLY OPEN"  
(LOW WATER)

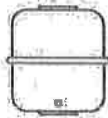

"NORMALLY CLOSED"  
(FILL)

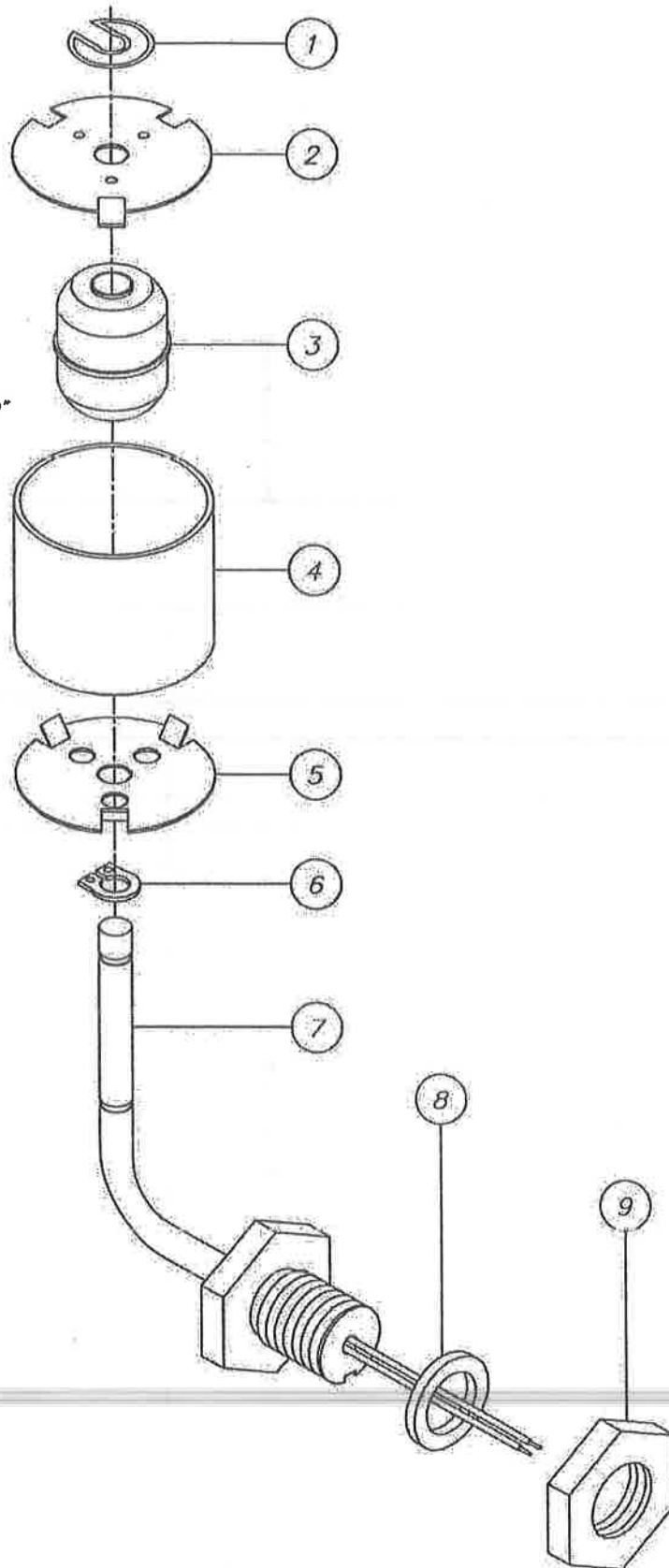

**MADISON FLOAT SWITCH ASSEMBLY**

ITEM	DESCRIPTION	REMARKS	REQ.	PART NO.
1	WIRE CLIP FLOAT SWITCH			P67-5915
2	CAP. SLOSH SHEILD (NO HOLES)			A10-5776
3	FLOAT, FLOAT SWITCH			A10-5760
4	TUBE, SLOSH SHIELD			A10-5775
5	CAP. SLOSH SHIELD (WITH HOLES)			P49-5926
6	RETAINER, GROVELESS CLIP			P67-5761
7	BODY, FLOAT SWITCH			A10-5790
8	WASHER, RED SILICONE			A10-5762
9	LOCKNUT 1/2" NPT S.S.'			A10-1446
	ASSEMBLY, FLOAT SWITCH (FILL INCLUDES ITEMS 1-8)			A10-5756
	ASSEMBLY, FLOAT SWITCH (LOW WATER INCLUDES ITEMS 1-8)			A10-5757

# THERMOSTATS

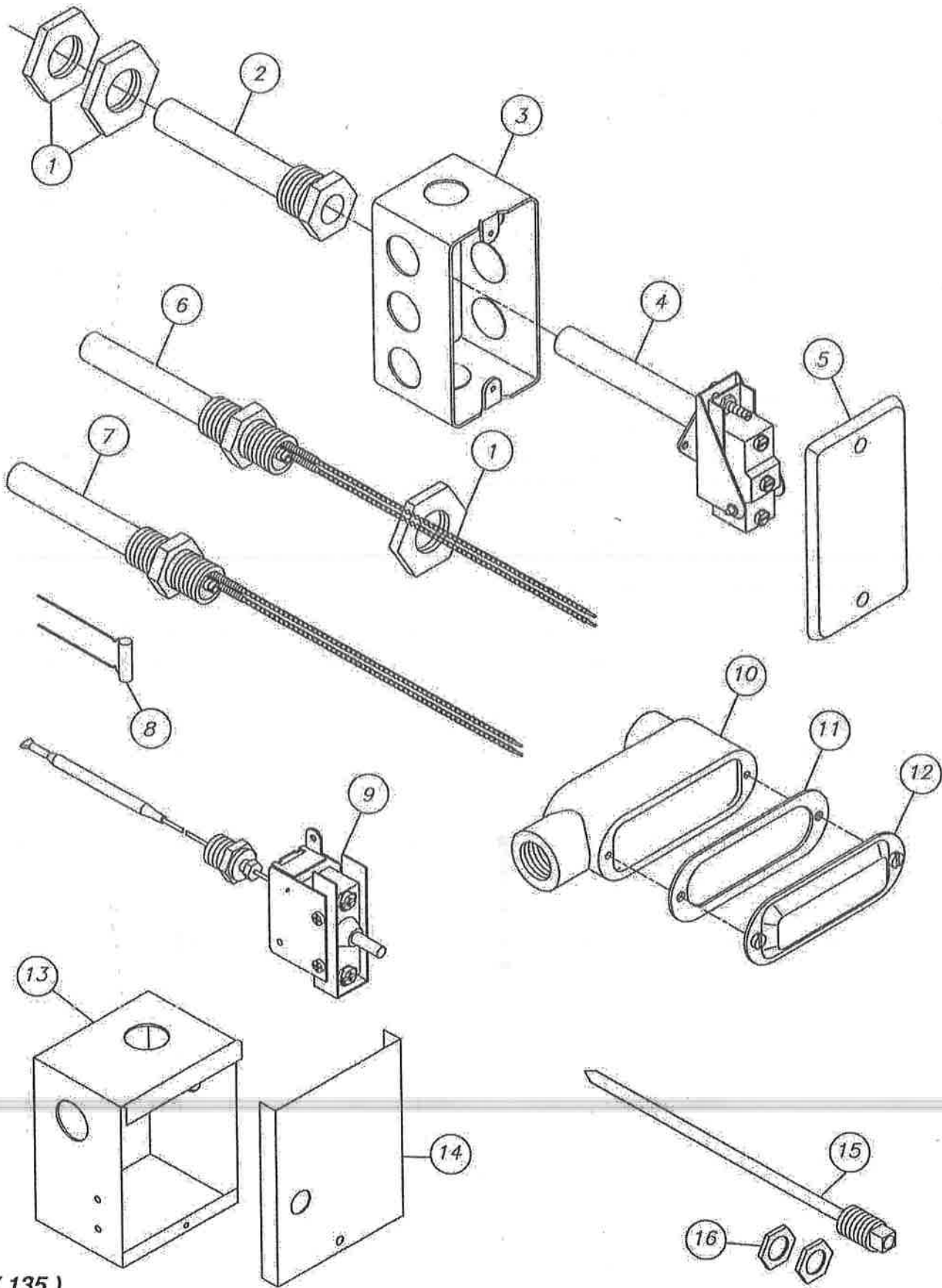

(135)



### THERMOSTATS

ITEM	DESCRIPTION	REMARKS	REQ.	PART NO.
1	LOCKNUT 3/4			A10-1859
2	BULB HOUSING ASSM.			A10-1858
3	BOX ELECTRIC 2 X 4			P48-1242
4	THERMOSTAT FENWAL			P65-1185
5	COVER JUNCTION BOX 2 X 4			P48-1285
6	THERMOSTAT CONTACTS CLOSE ON RISE USED FOR COLD WATER AQUASTAT.			P65-1184
7	THERMOSTAT CONTACTS OPEN ON RISE USED ON STEAM BOOSTERS.			P65-1183
8	CAPACITOR .001-600V			P41-2462
9	SWITCH HI-LIMIT CUTOFF TEMP. CONT.			P65-5776
10	COVER 1/2" JUNCTION BOX			P52-2019
11	GASKET 1/2" NEO			P52-2018
12	UNILET BODY (USED WITH P65-1183)			P52-2014
13	HIGH LIMIT BOX			A10-4587
14	HI LIMIT COVER PLATE 3 1/2 X 4 1/4			A10-4588
15	HI LIMIT WELL			A10-5946
16	LOCK NUT FOR HI LIMIT WELL		2	A10-1446

\* TO ORDER SUPPLY MACHINE MODEL AND SERIAL NUMBER ( 136 )

# ELECTRICAL FITTINGS

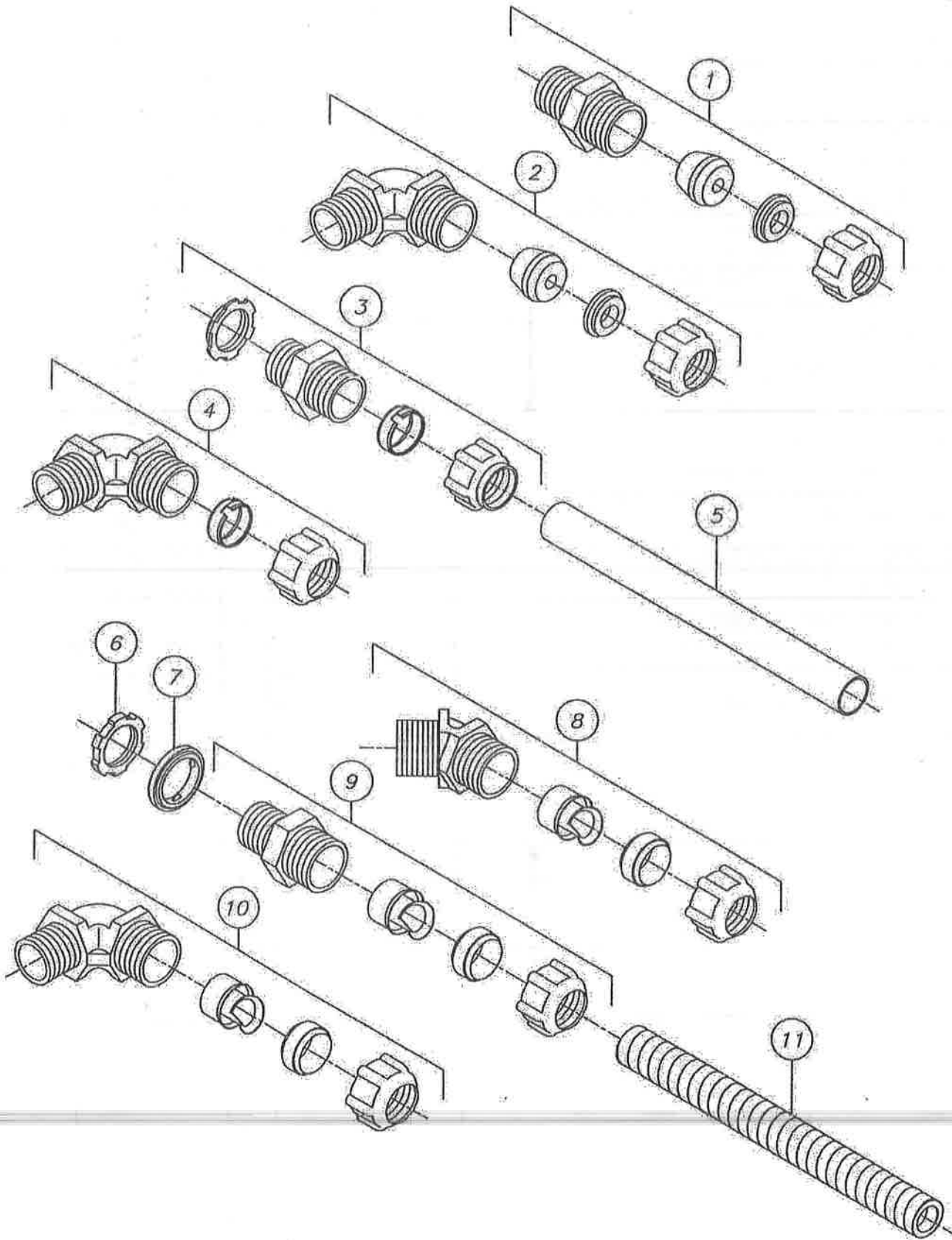







Project Name: [Illegible]  
Location: [Illegible]  
Scale: [Illegible]

0001-540 (0001)

Project Name: [Illegible]  
Location: [Illegible]



The Stero Company  
1758 Corporate Circle  
Petaluma, CA 94954

---

(800) 762-7600

Toll free to Parts & Service  
(877)-762-3200