

# THE STERO COMPANY GEN 2 ER SERIES TYPE DISHWASHERS

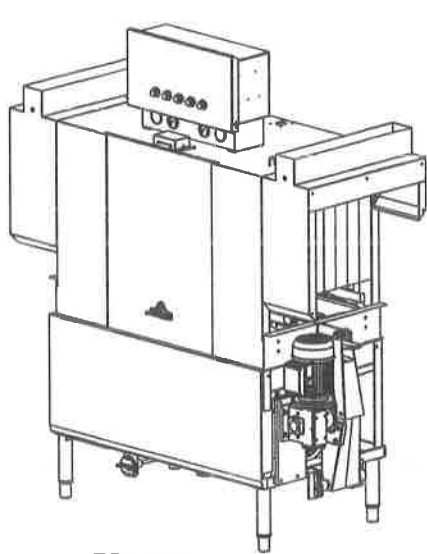

ER-44

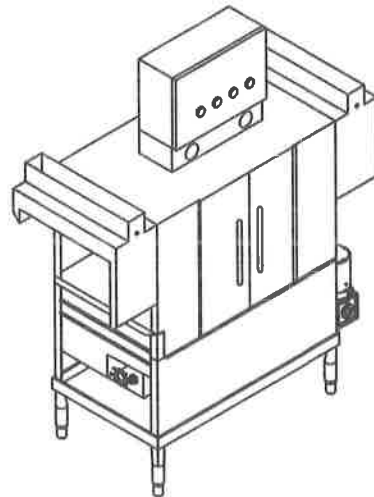

ER-44 w/ cab doors

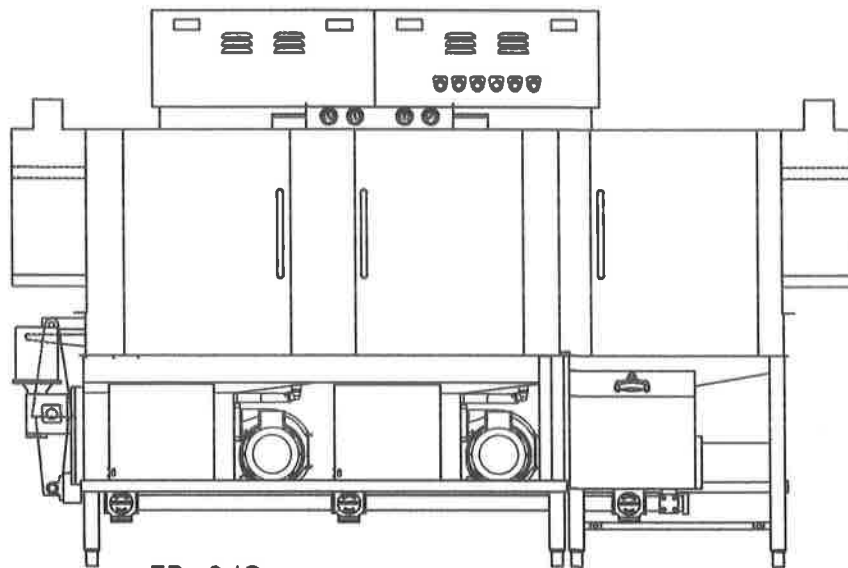

ER-94S



MODEL# \_\_\_\_\_  
SERIAL# \_\_\_\_\_

THE STERO COMPANY  
1758 CORPORATE CIRCLE  
PETALUMA, CA. 94954  
(800) 762-7600  
FAX# (707) 762-1954  
ERP-GEN201 04/2020





# TABLE OF CONTENTS

DESCRIPTION	PAGE #
FRAMES	1 - 2
SCRAPPER FRAMES	3 - 4
FRONT PANELS	5 - 6
SCRAPPER FRONT PANELS	7 - 8
TANK ASSEMBLY	9 - 10
2 TANK ASSEMBLY	11 - 12
22" SCRAPPER TANK ASSEMBLY	13 - 14
30" SCRAPPER TANK ASSEMBLY	15 - 16
CORNER SCRAPPER TANK ASSEMBLY	17 - 18
SCRAP CATCHMENT & BASKETS	19 - 20
STRAINER PANS	21 - 22
ER-44 BASED STRAINER PAN LOCATION	23 - 24
ER-64 BASED STRAINER PAN LOCATION	25 - 26
LIFT UP DOORS	27 - 28
CABINET STYLE DOORS	29 - 30
EXHAUST VENT COWLS	31 - 32
CURTAINS & RODS	33 - 34
SIDE LOADER PARTS	35 - 36
368 PUMP & 2 HP MOTOR	37 - 38
321 PUMP & 1 HP MOTOR	39 - 40
MOTOR & GEAR BOX DRIVE ASSEMBLY	41 - 42
STRAIGHT DRIVE SECTION ASSEMBLY	43 - 44
TRACKS	45 - 46
START & RINSE LEVER ASSEMBLIES	47 - 48
SCRAPPER TANK SPRAY ASSEMBLY	49 - 50
CORNER SCRAPPER TANK SPRAY ASSEMBLY	51 - 52
WASH/RINSE SPRAY ASSEMBLY	53 - 54
FINAL RINSE ASSEMBLY	55 - 56
TANK HEAT	57 - 58
HEAT ENCLOSURES & HIGH LIMIT	59 - 60
STEAM BOOSTER	61 - 62
ST-30 ELECTRIC BOOSTER	63 - 64
COMMON PLUMBING PARTS	65 - 66
DRAIN & OVERFLOW ASSEMBLY	67 - 68



# FRAMES

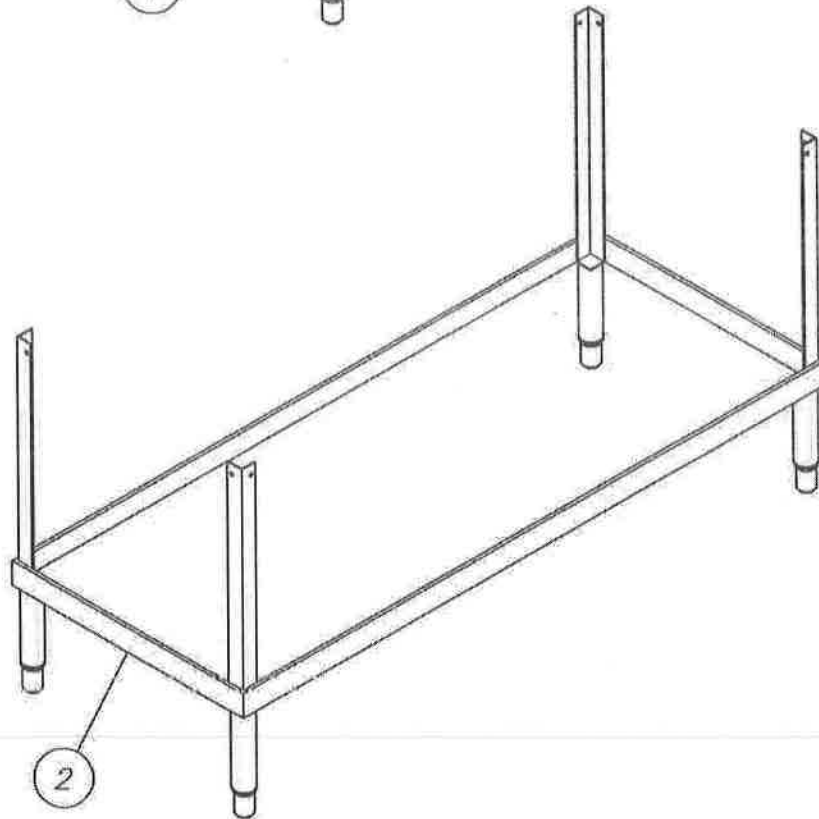
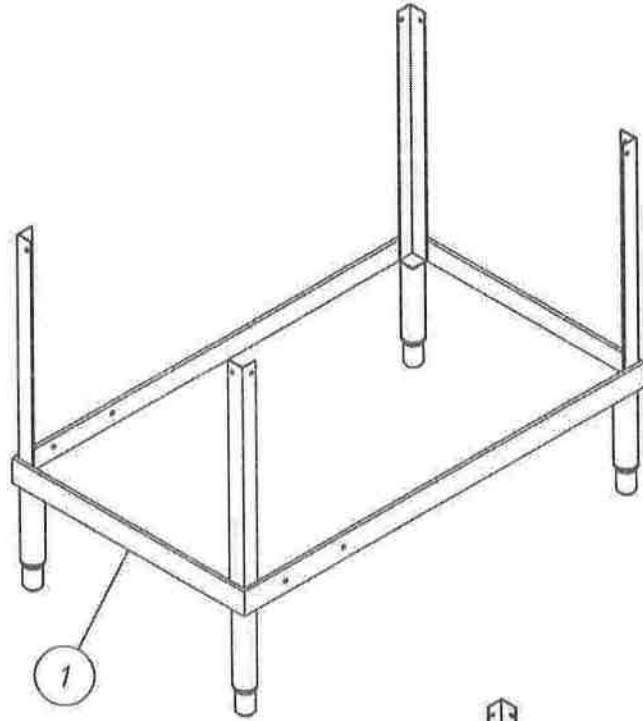

(01)



# SCRAPPER FRAMES

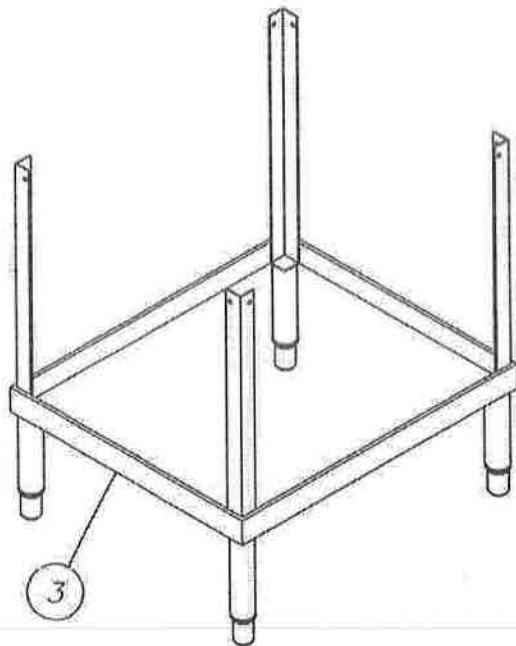
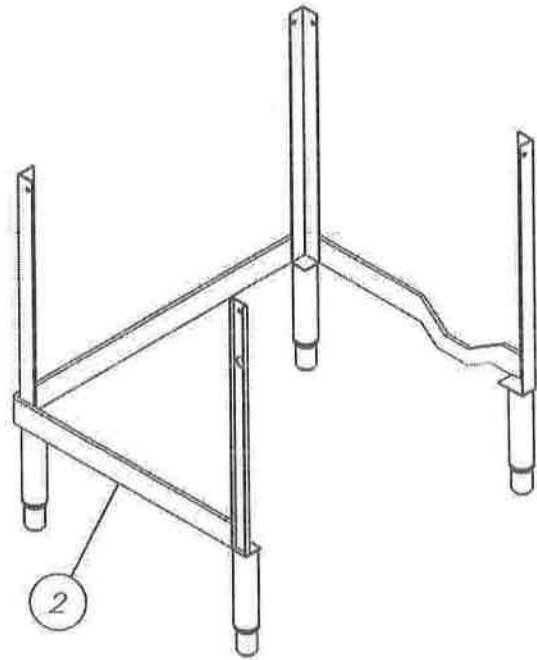
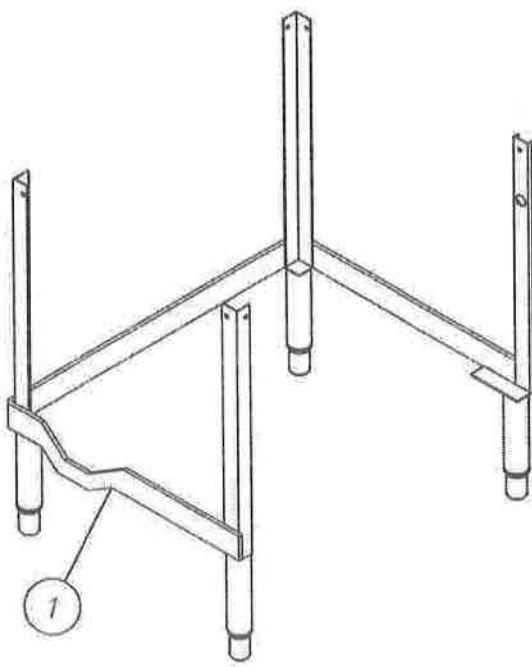



## SCRAPPER FRAMES

ITEM	DESCRIPTION	REMARKS	QTY	PART#
1	FRAME, ASSEMBLY 29" SCRAPPER	LEFT TO RIGHT		B10-2584-LR
2	FRAME, ASSEMBLY 29" SCRAPPER	RIGHT TO LEFT		B10-2584-RL
3	FRAME, ASSEMBLY CORNER CATCH			B10-3505
	FRAME, ASSEMBLY END CATCH			B10-3508

\* TO ORDER, SUPPLY MACHINE MODEL AND SERIAL NUMBER (04)

# FRONT PANELS

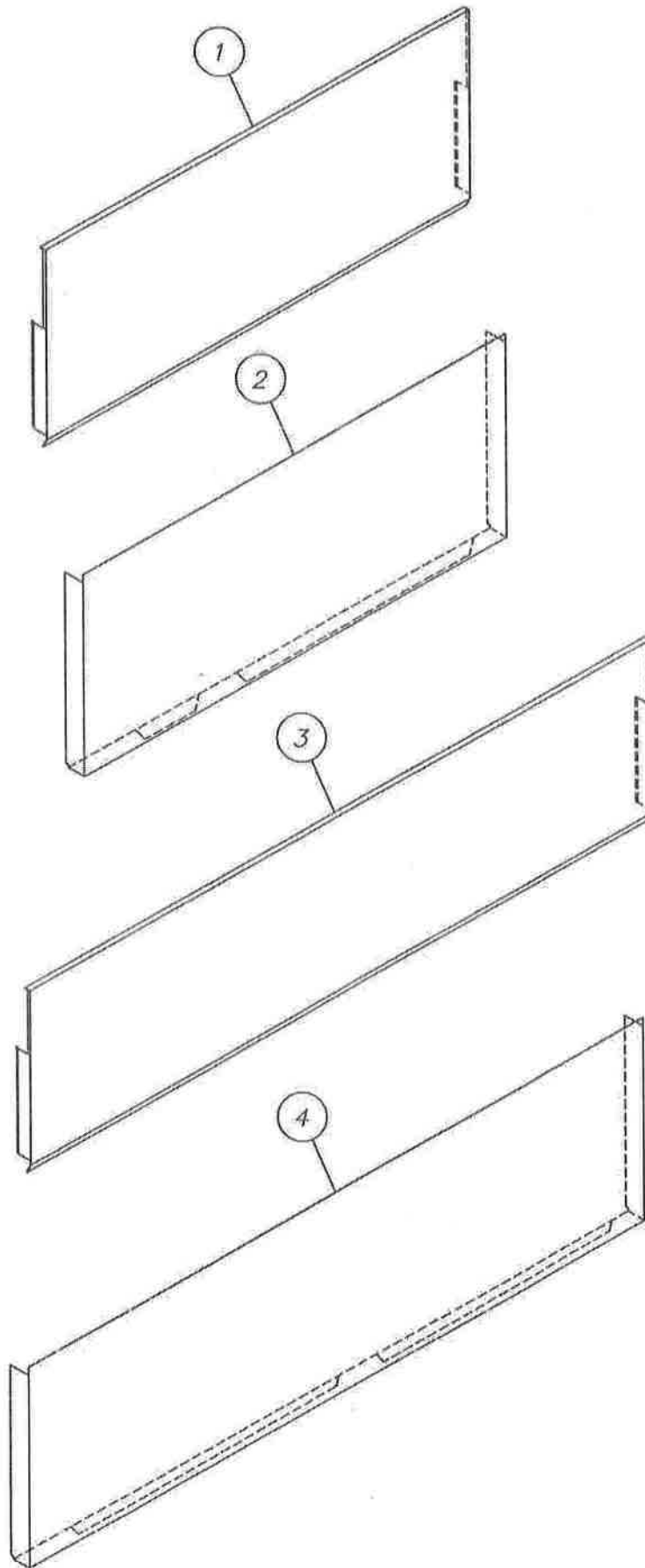

## FRONT PANELS

ITEM	DESCRIPTION	REMARKS	QTY	PART#
1	PANEL, FRONT ER-44 STD DOOR	1 TANK		A10-4388
2	PANEL, FRONT ER-44 CAB DOOR	1 TANK		A10-4386
3	PANEL, FRONT ER-64 STD DOOR	2 TANK		B10-2641
4	PANEL, FRONT ER-64 CAB DOOR	2 TANK		B10-2641CAB
NLA	PANEL,FRONT ER-76SC-CAB DOOR-LR			B10-3816CAB-LR
NLA	PANEL,FRONT ER-76SC-CAB DOOR-RL			B10-3816CAB-RL

\* TO ORDER, SUPPLY MACHINE MODEL AND SERIAL NUMBER ( 06 )

# SCRAPPER FRONT PANELS

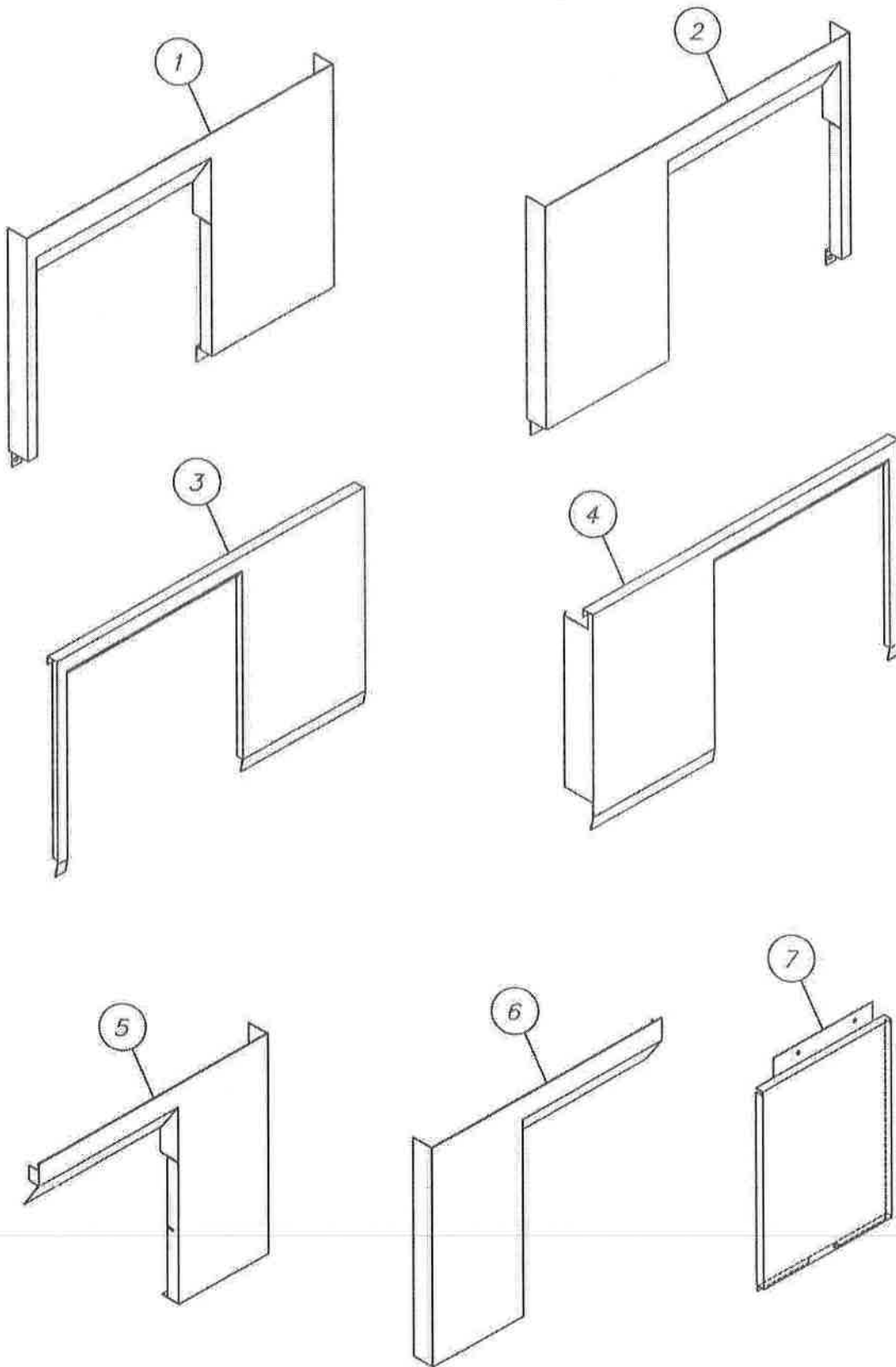



# TANK ASSEMBLY

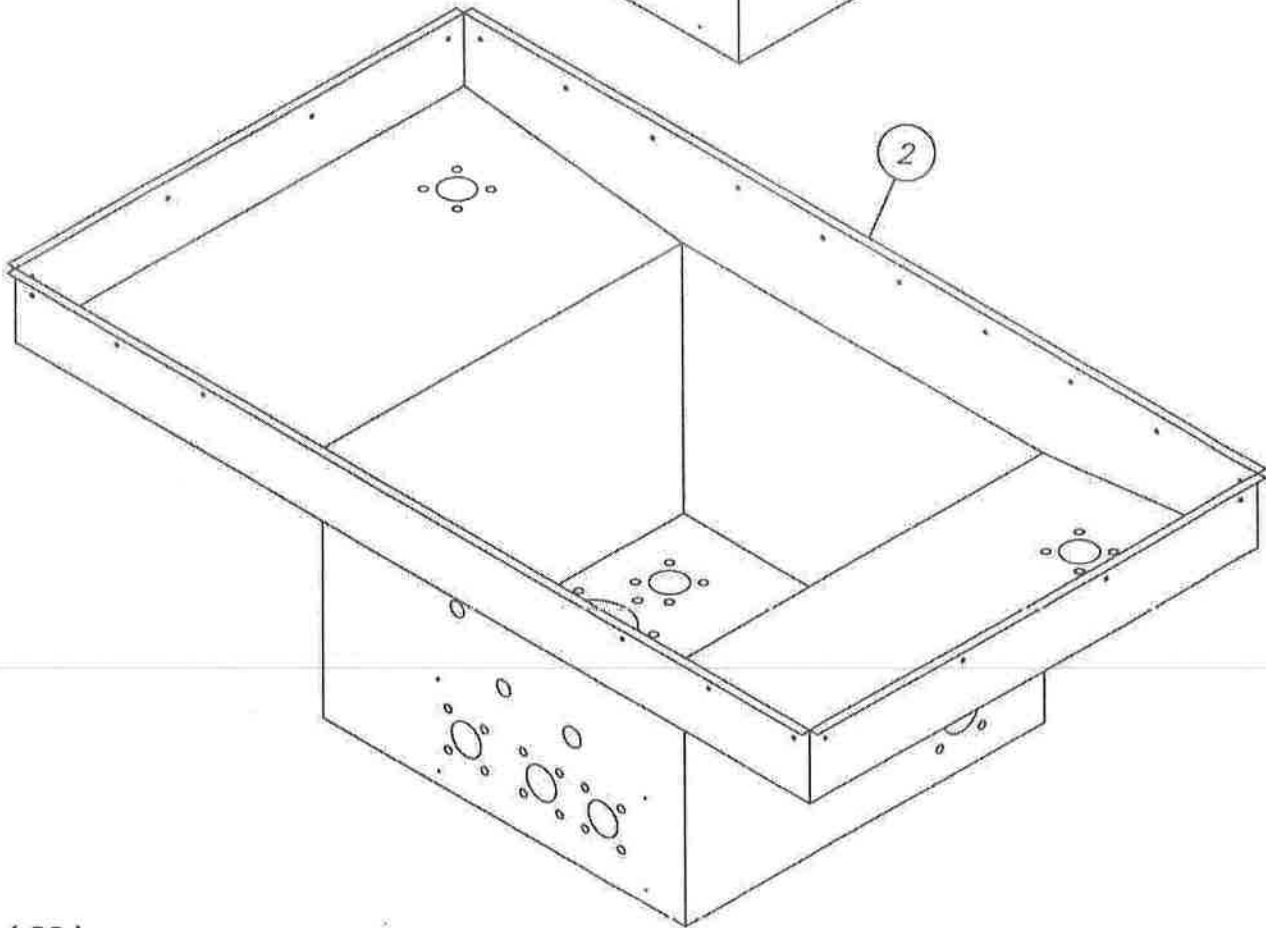
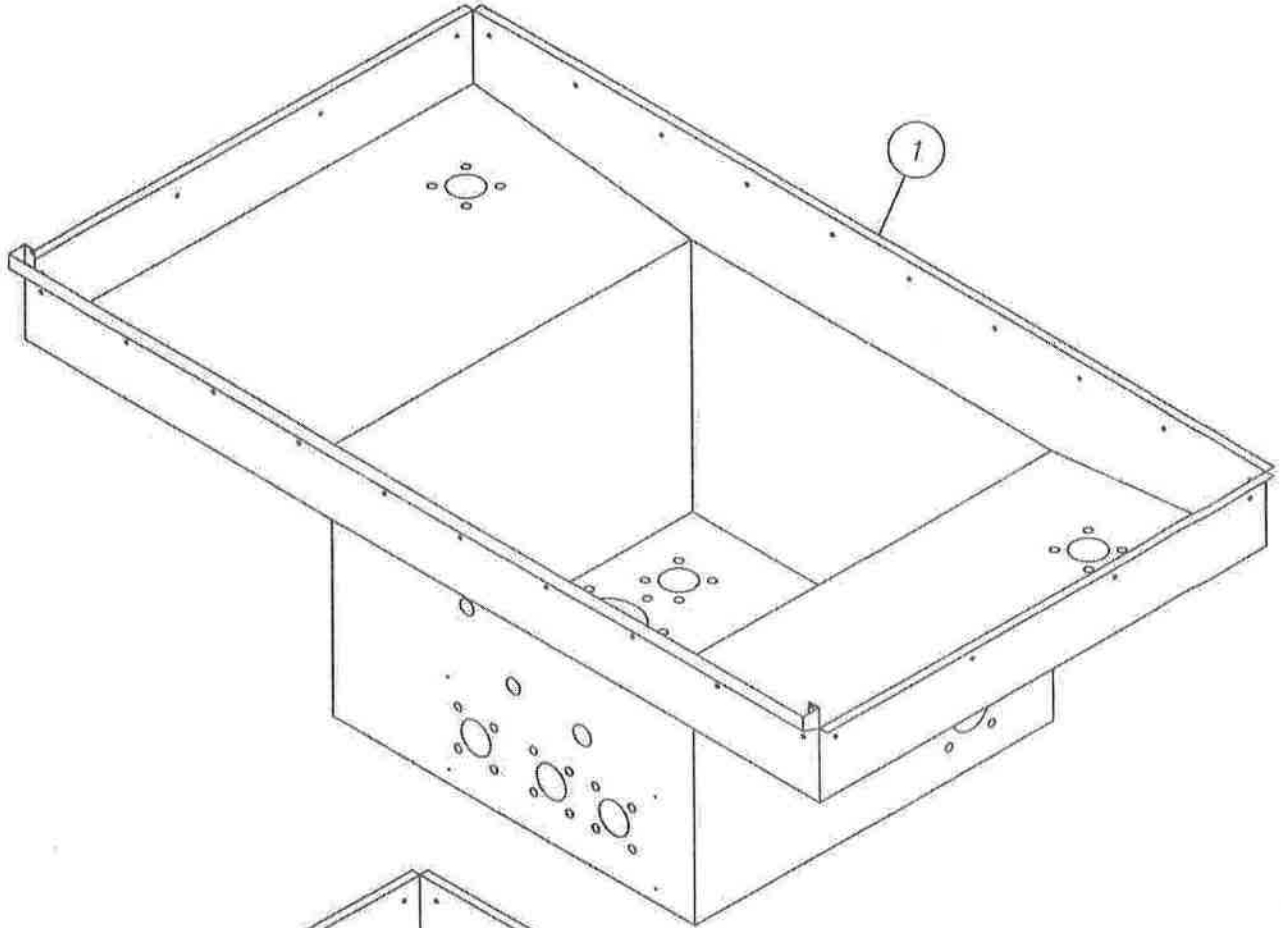

(09)



## 2 TANK ASSEMBLY

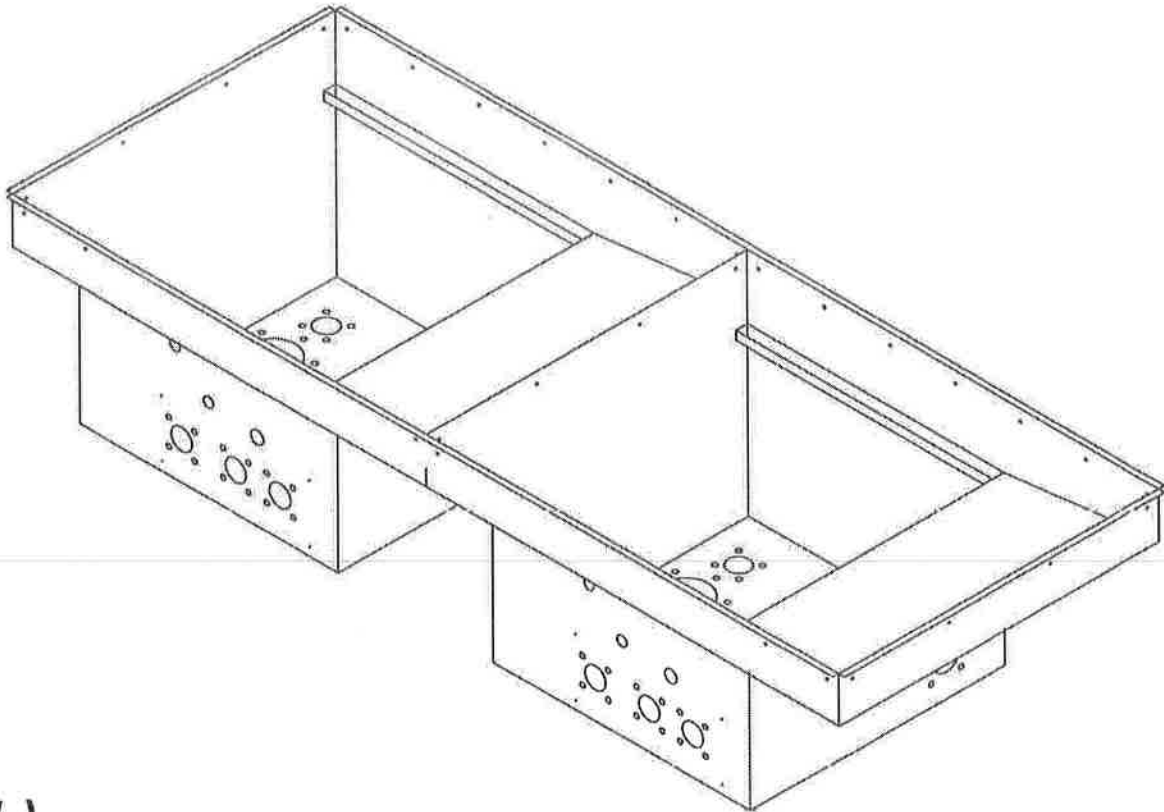
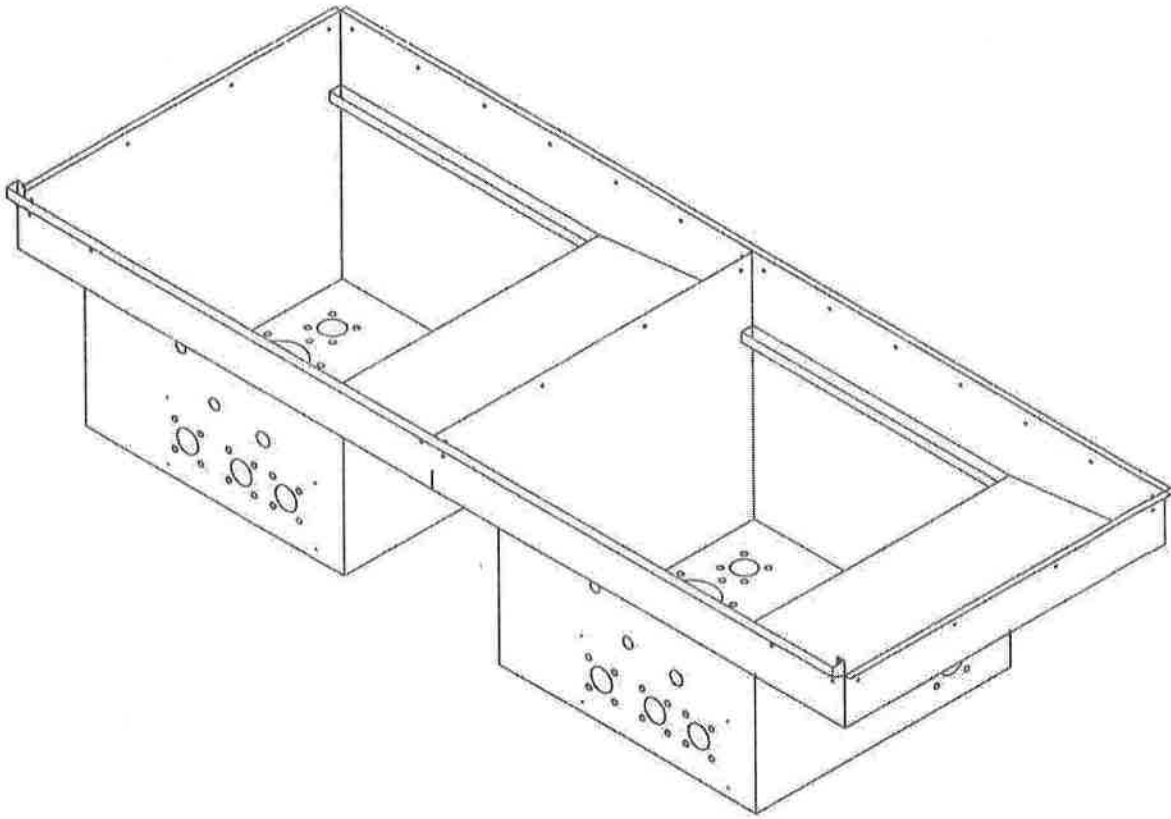

(11)



## 2 TANK ASSEMBLY

ITEM	DESCRIPTION	REMARKS	QTY	PART#
1	TANK ASSY ER-64 CABINET DOOR			B10-2658CAB-EH
2	TANK ASSY ER-64 STANDARD DOOR			B10-2658-EH

\* TO ORDER, SUPPLY MACHINE MODEL AND SERIAL NUMBER ( 12 )

# 22" SCRAPPER TANK ASSEMBLY

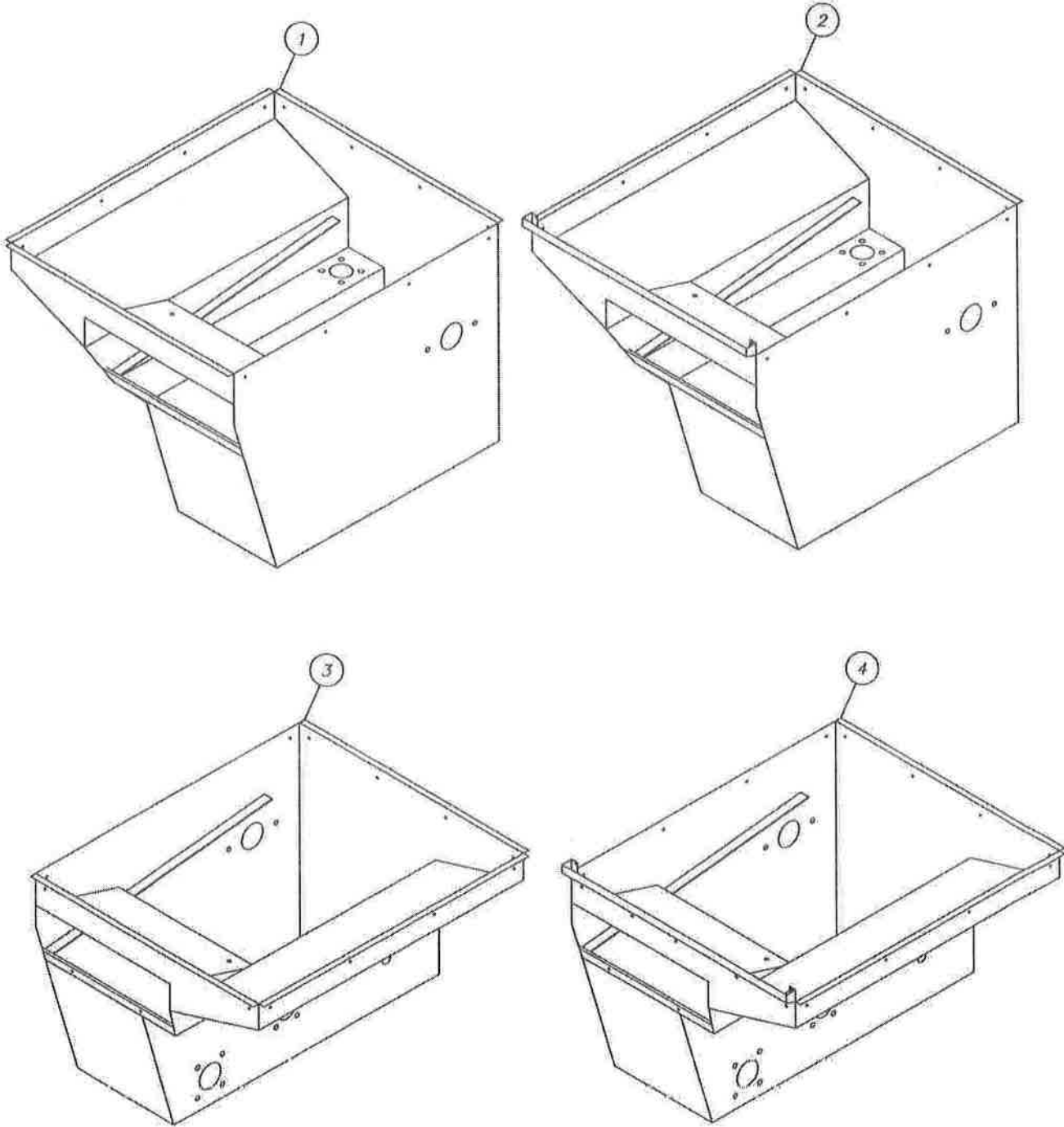

# 22" SCRAPER TANK ASSEMBLY

ITEM	DESCRIPTION	REMARKS	QTY	PART#
1	TANK ASSY 22" SCRAPPER-LR-STD DOOR			B10-2283-LR-S
2	TANK ASSY 22" SCRAPPER-LR-CAB DOOR			B10-2283-LR-C
3	TANK ASSY 22" SCRAPPER-RL-STD DOOR			B10-2283-RL-S
4	TANK ASSY 22" SCRAPPER-RL-CAB DOOR			B10-2283-RL-C

# 30" SCRAPPER TANK ASSEMBLY

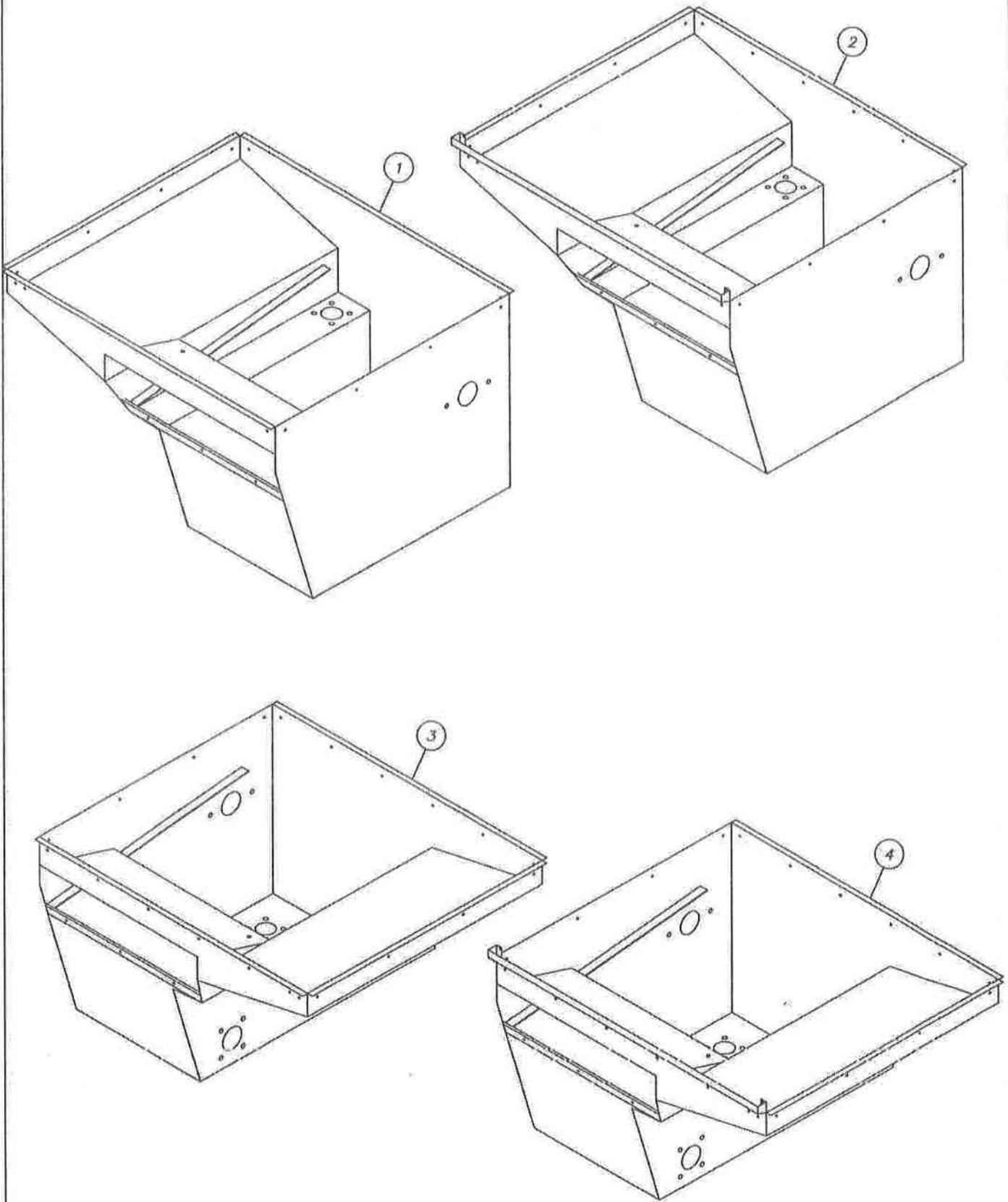

## 30" SCRAPPER TANK ASSEMBLY

ITEM	DESCRIPTION	REMARKS	QTY	PART#
1	TANK ASSY 29" SCRAPPER-LR-STD DOOR			B10-2575-LR-S
2	TANK ASSY 29" SCRAPPER-LR-CAB DOOR			B10-2575-LR-C
3	TANK ASSY 29" SCRAPPER-RL-STD DOOR			B10-2575-RL-S
4	TANK ASSY 29" SCRAPPER-RL-CAB DOOR			B10-2575-RL-C

\* TO ORDER, SUPPLY MACHINE MODEL AND SERIAL NUMBER ( 16 )

# 30" CORNER SCRAPER TANKS

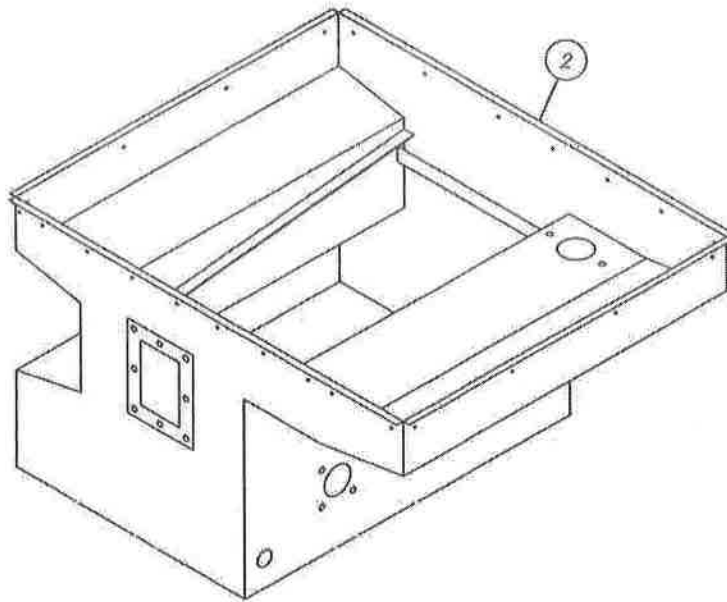
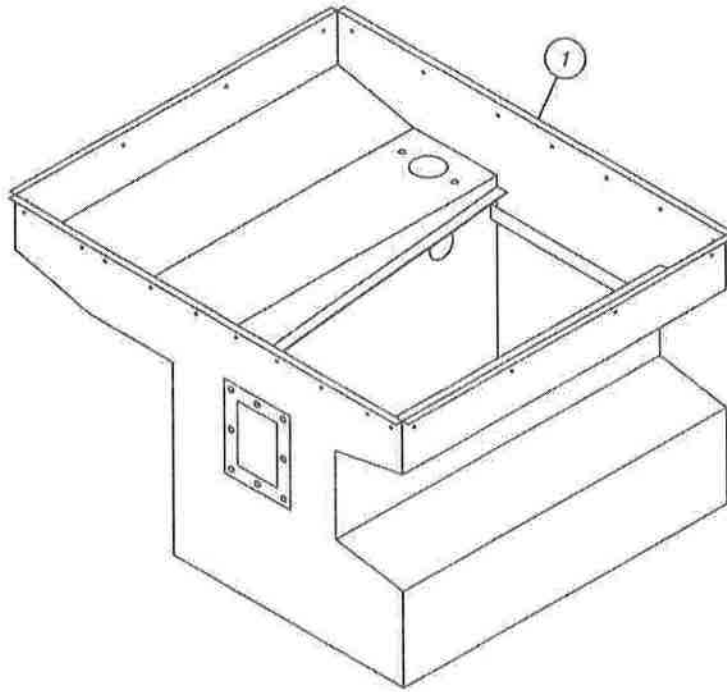

# 30" CORNER SCRAPER TANKS

ITEM	DESCRIPTION	REMARKS	QTY	PART#
1	TANK ASSY 30" SCR CORNER R-L			B10-3225-RL
2	TANK ASSY 30" SCR CORNER L-R			B10-3225-LR

\* TO ORDER, SUPPLY MACHINE MODEL AND SERIAL NUMBER ( 18 )

# SCRAP CATCHMENT & BASKETS

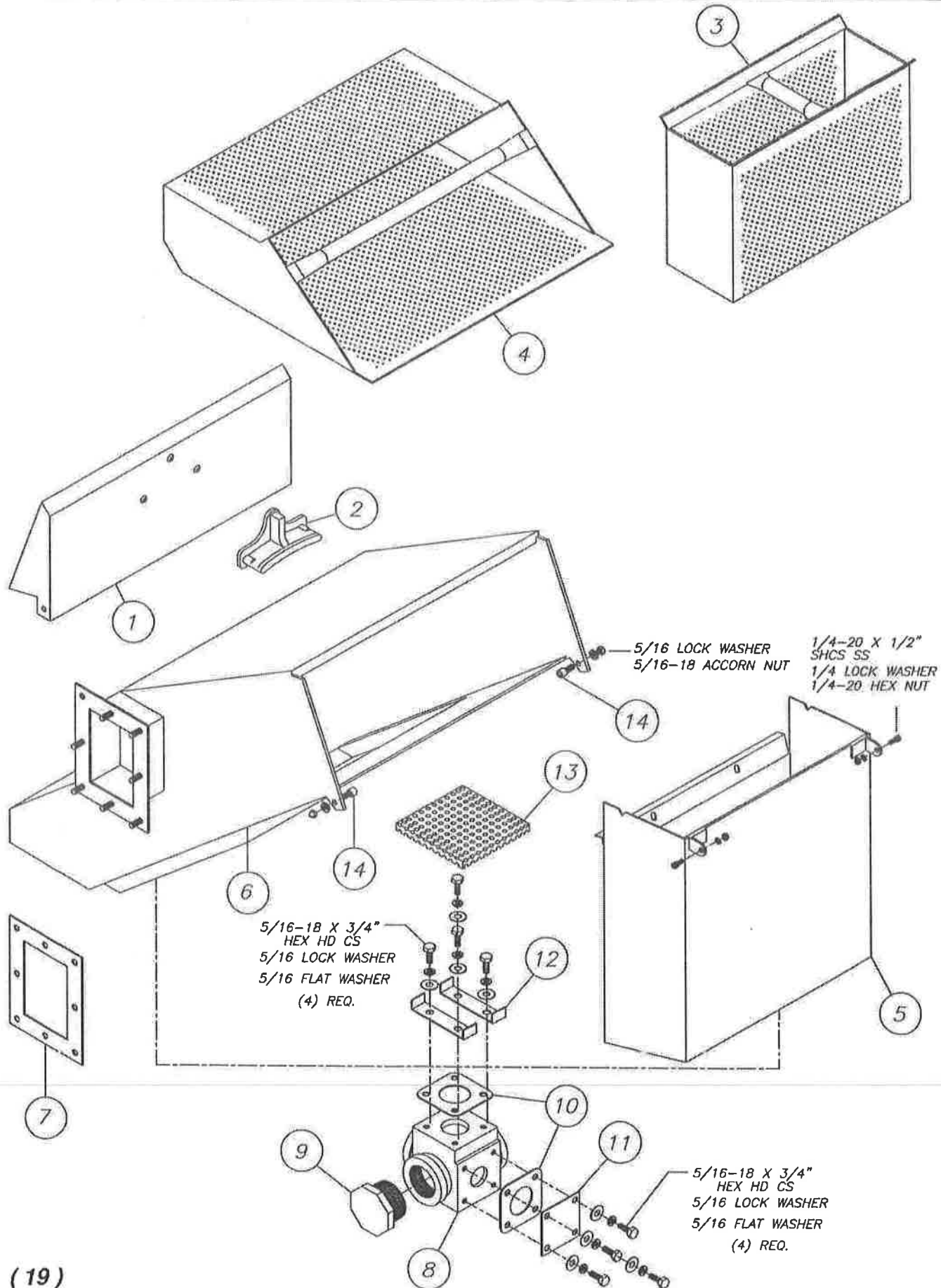



## SCRAP CATCHMENT & BASKETS

ITEM	DESCRIPTION	REMARKS	QTY	PART#
1	DOOR SCRAP CATCHMENT OUTBOARD			B10-2615
2	BLUE PLASTIC DOOR HANDLE W/SCREWS			B59-1448
3	SCRAP BASKET ASSY 22"	12-1/4" WIDE		B10-2259
	SCRAP BASKET ASSY 29"	16-1/2" WIDE		B10-6029
4	SCRAP BASKET SIDE MTD CATCHMENT	16-1/2" WIDE		C10-2614
5	SCRAP CATCHMENT ASSY 22"	L-R		B10-2266
	SCRAP CATCHMENT ASSY 22"	R-L		B10-3595
	SCRAP CATCHMENT ASSY 29"	L-R		A10-5628
	SCRAP CATCHMENT ASSY 29"	R-L		A10-6732
6	SCRAPPER CATCHMENT, SIDE MOUNTED			C10-2613
7	GASKET, SIDE MOUNT CATCHMENT			A10-3788
8	TEE OVERFLOW ASSY DRAIN TEE #97			B10-1871
9	PVC PLUG 2"			P68-1698
10	DRAIN TEE BOX GASKET			A57-1114
11	STAINLESS STEEL BLANK PLATE			A10-3326
12	RETAINER, SCRAPER CATCHMENT SCREEN			A10-2625
13	SCREEN DRAIN	5.25" X 5.25"		A10-2616
14	SCREW, HINGE CLEAN OUT DOOR			P67-6769

\* TO ORDER, SUPPLY MACHINE MODEL AND SERIAL NUMBER ( 20 )

# STRAINER PANS

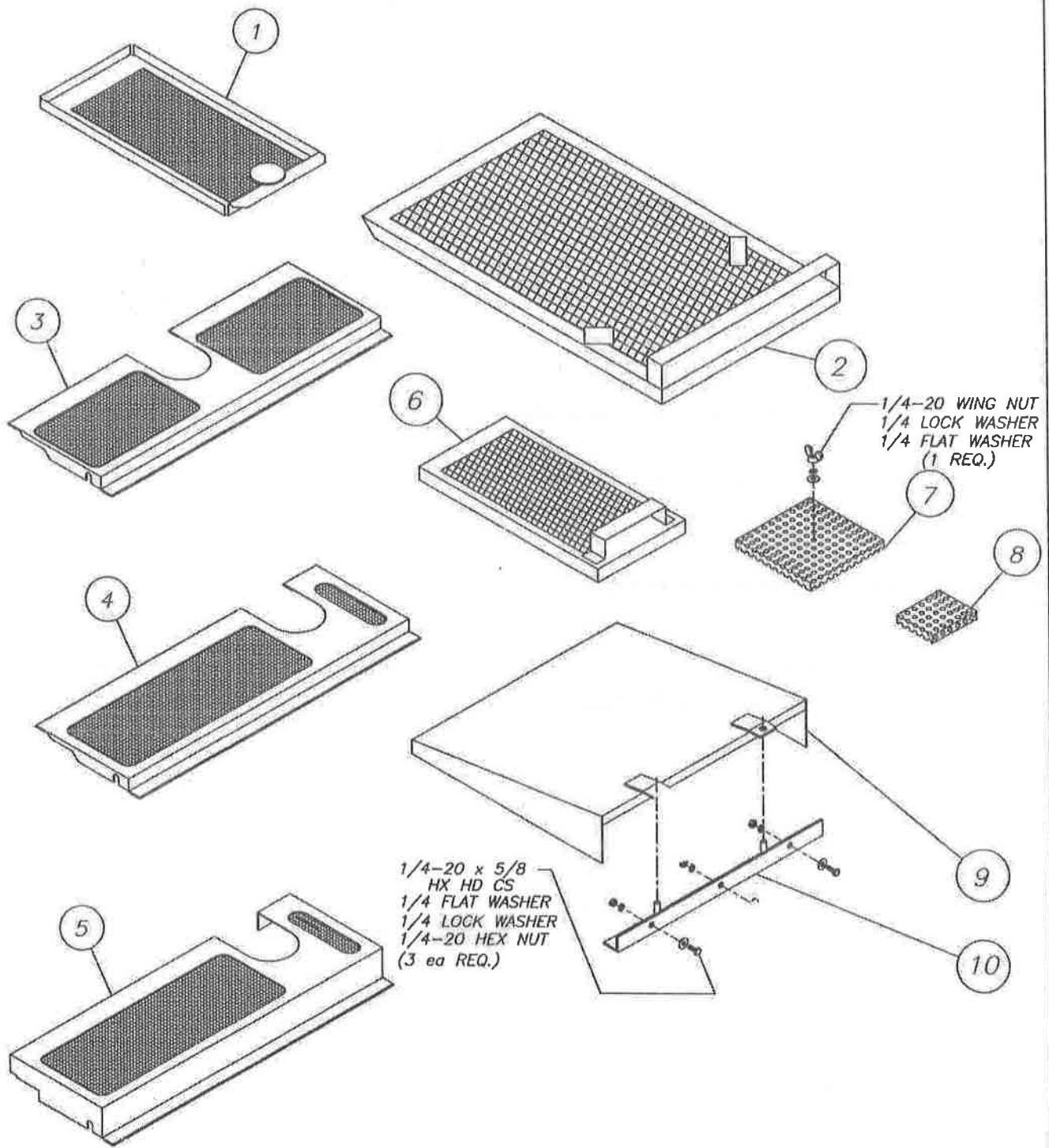

## STRAINER PANS

ITEM	DESCRIPTION	REMARKS	QTY	PART#
1	PAN, STRAINER WASH TANK			A10-6647
2	PAN, STRAINER SCRAP SCREEN	12-1/2 X 21		B10-2261
	PAN, STRAINER SCRAP SCREEN	16-1/2 X 21		B10-6030
3	SUPPORT, STRAINER PAN ER-44			A10-6979
4	SUPPORT, STRAINER PAN ER-64 TANKS			A10-6737
5	SUPPORT, STRAINER PAN-GEN2 TANK			A10-7107
6	STRAINER PAN	12-1/2 X 21		A10-2716
7	SCREEN DRAIN			A10-2616
8	SCREEN OVERFLOW			A10-7058
9	DIVERTER, SCRAP TANK WATER	CORNER SCRAPPER		B10-3797
10	BRACKET, SCRAP TANK WATER DIVERTER	CORNER SCRAPPER		A10-3798

\* TO ORDER, SUPPLY MACHINE MODEL AND SERIAL NUMBER ( 22 )

# ER-44 BASED STRAINER PAN LOCATION

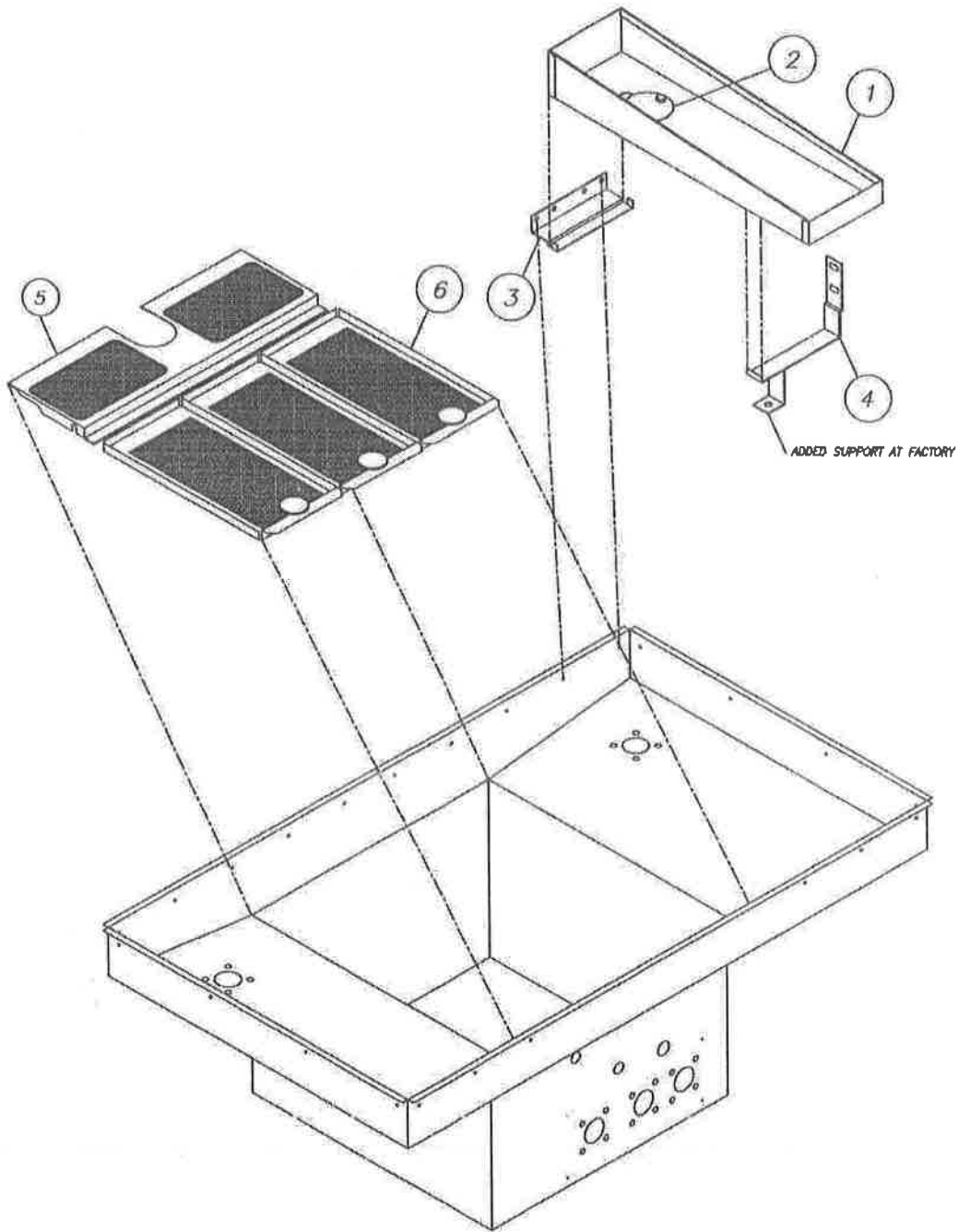

# TYPICAL ER-44 TANK ASSEMBLY

ITEM	DESCRIPTION	REMARKS	QTY	PART#
1	PAN, RINSE SAVER			B10-2560
2	DIVERTER, RINSE SAVER PAN			A10-2559
3	BRACKET, RINSE SAVER PAN REAR			A10-6974
4	BRACKET, RINSE SAVER PAN FRONT			A10-6975
5	SUPPORT, STRAINER PAN ER-44			A10-6979
6	PAN, STRAINER WASH TANK			A10-6647

\* TO ORDER, SUPPLY MACHINE MODEL AND SERIAL NUMBER ( 24 )

# ER-64 BASED STRAINER PAN LOCATION

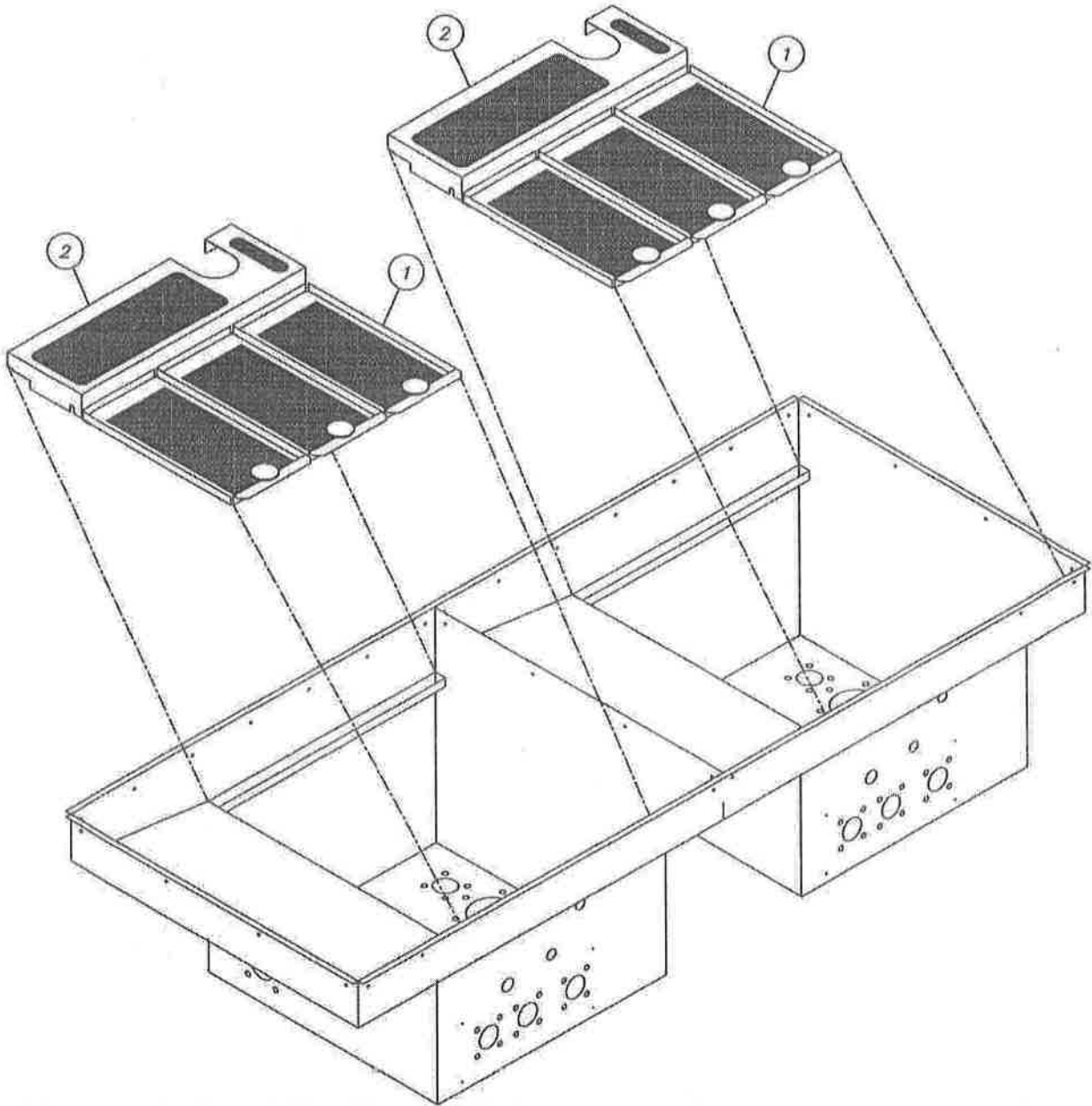



# LIFT UP DOORS

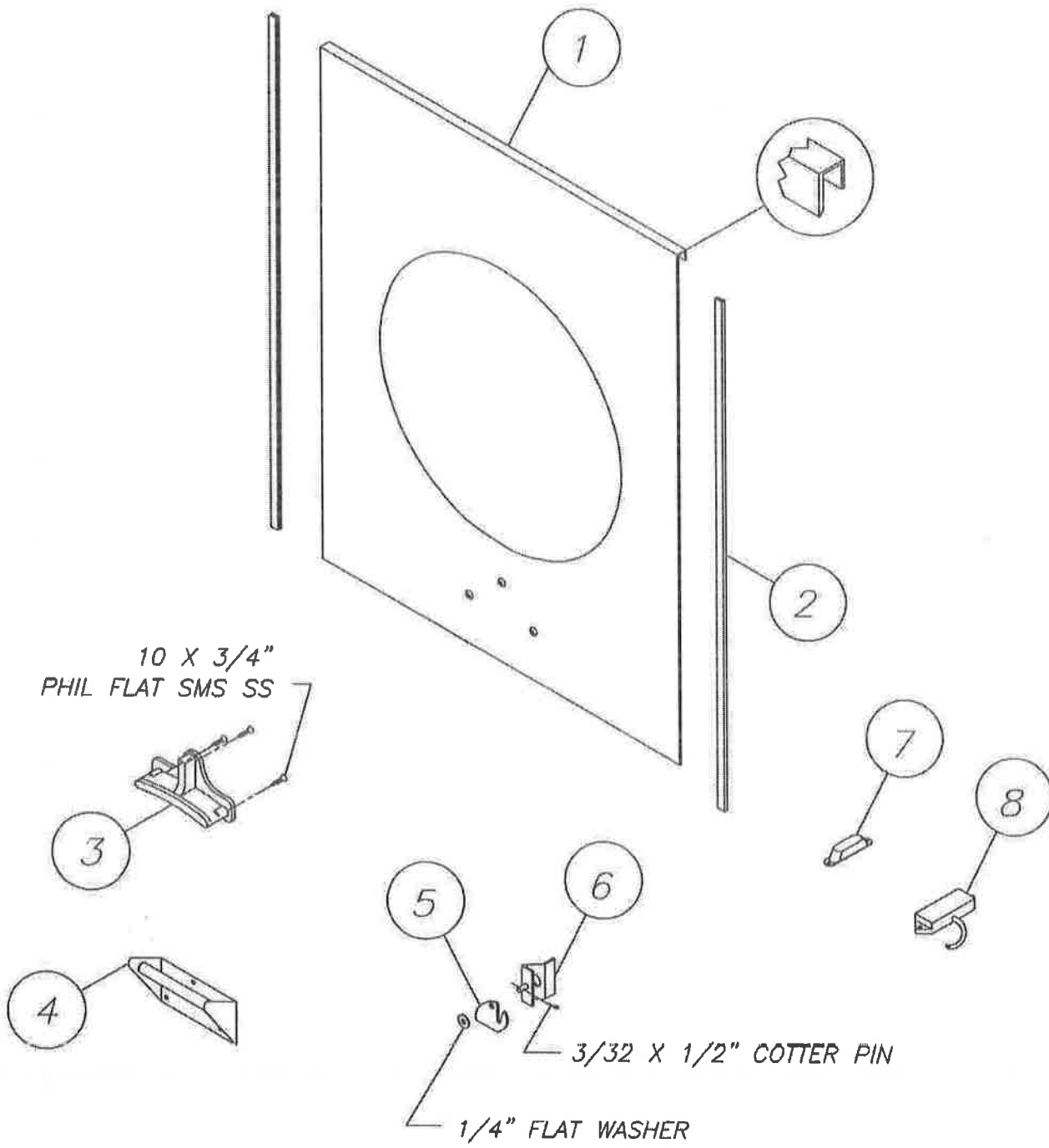



## LIFT UP DOORS

ITEM	DESCRIPTION	REMARKS	QTY	PART#
1	DOOR, TEFLON 23.5 X 29	OLD STD.		A10-5844
	DOOR, TEFLON 23.5 X 32	STD.		A10-5978
	DOOR, TEFLON 23.5 X 35	PLUS 3" HOOD		A10-5979
	DOOR, TEFLON 17.5 X 29. 22" SCRAPPER	OLD STD.		A10-5846
	DOOR, TEFLON 17.5 X 32. 22" SCRAPPER	STD.		A10-5982
	DOOR, TEFLON 17.5 X 35. 22" SCRAPPER	PLUS 3" HOOD		A10-5983
2	GUIDE, BLUE TEFLON DOOR 28-1/4"	OLD STD.		P57-5775
	GUIDE, BLUE TEFLON DOOR 31-1/2"	STD.		P57-6948
	GUIDE, BLUE TEFLON DOOR 36-1/2"	PLUS 3" HOOD		P57-5286
3	HANDLE, DOOR W/SCREWS			B59-1448
4	HANDLE, STAINLESS STEEL	PRISON PKG.		A10-3314
5	CATCH SAFETY			A10-1578
6	BRACKET, DOOR SFETY CATCH			A10-1759
7	MAGNET, ASSEMBLY STERO REED			A10-4275
8	SWITCH, REED WITH SJ CORD			B10-5595

ER-44 HAS 1 LIFT UP DOOR

ER-64 HAS 2 LIFT UP DOORS

ER-66S HAS 1 LIFT UP & 1 22" LIFT UP SCRAPPER DOOR

ER-76S HAS 2 LIFT UP DOORS

ER-86S HAS 2 LIFT UP & 1 22" LIFT UP SCRAPPER DOOR

ER-94S HAS 3 LIFT UP DOORS

CORNER SCRAPPERS DO NOT HAVE A DOOR

\* TO ORDER, SUPPLY MACHINE MODEL AND SERIAL NUMBER ( 28 )

# CABINET STYLE DOORS

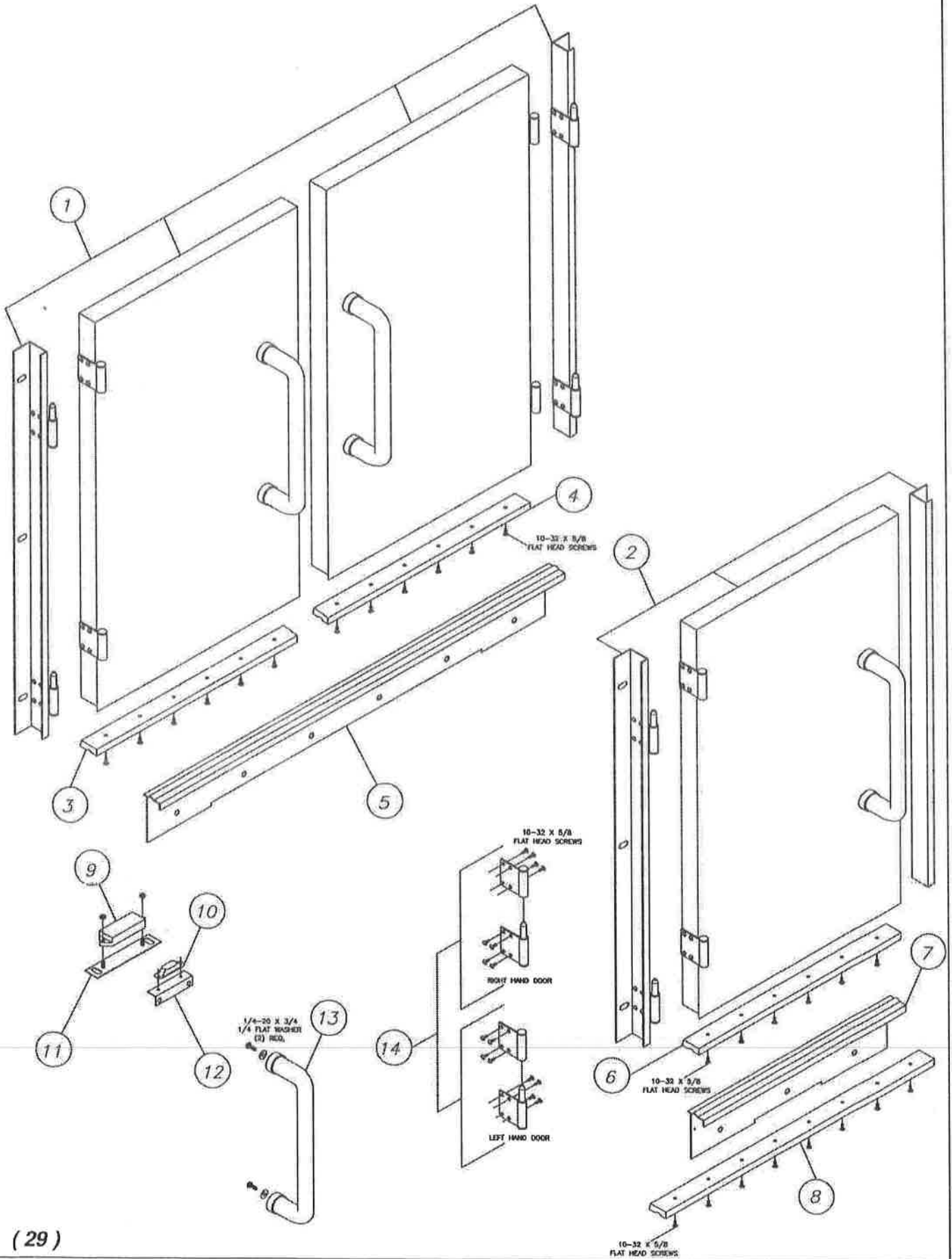

## CABINET STYLE DOORS

ITEM	DESCRIPTION	REMARKS	QTY	PART#
1	DOORS, DOUBLE 18" CABINET DOOR ASSEMBLY	INCLUDES #3, 4, 13 & 14		* Z99-0037
2	DOOR, SINGLE 18" CABINET DOOR ASSEMBLY	INCLUDES #6, 13 & 14		* Z99-0035
	DOOR, SINGLE 24" CABINET DOOR ASSEMBLY	INCLUDES #8, 13 & 14		* Z99-0036
3	SEAL, 2 DOOR LEFT UHMW NARROW			A10-6691
4	SEAL, 2 DOOR RIGHT UHMW NARROW			A10-6692
5	THRESHOLD, 36" CABINET DOUBLE DOOR			A10-6725
6	SEAL, DOOR 18" UHMW NARROW			A10-6690
7	THRESHOLD, 18" NARROW DOOR			A10-6723
	THRESHOLD, 24" WIDE DOOR			A10-6724
8	SEAL, DOOR 24" WIDE DOOR			A10-6693
9	REED SWITCH ASSEMBLY			B10-4274
10	MAGNET, ASSY STERO REED B10-4274			A10-4275
11	BRACKET, INSULATED DOOR SWITCH			A10-6735
12	BRACKET, INSULATED DOOR MAGNET			A10-6736
13	HANDLE, TUBULAR INSULATED DOOR			A10-6703
14	HINGE, INSULATED CAB DOOR			P60-6680
	ER-44 HAS DOUBLE 18" CAB DOOR SET			
	ER-64 HAS 2 SINGLE 24" CAB DOOR			
	ER-66S HAS DOUBLE 18" SET & SINGLE 18" SCRAPPER DOOR			
	ER-76S HAS DOUBLE 18" SET AND SINGLE 24" SCRAPPER DOOR			
	ER-86S HAS 2 SINGLE 24" DOORS AND 1 SINGLE 18" SCRAPPER DOOR			
	ER-94S HAS 2 SINGLE 24" DOORS AND 1 SINGLE 24" SCRAPPER DOOR			
	CORNER SCRAPPERS DO NOT HAVE A DOOR			

\* TO ORDER, SUPPLY MACHINE MODEL AND SERIAL NUMBER ( 30 )

# EXHAUST VENT COWLS

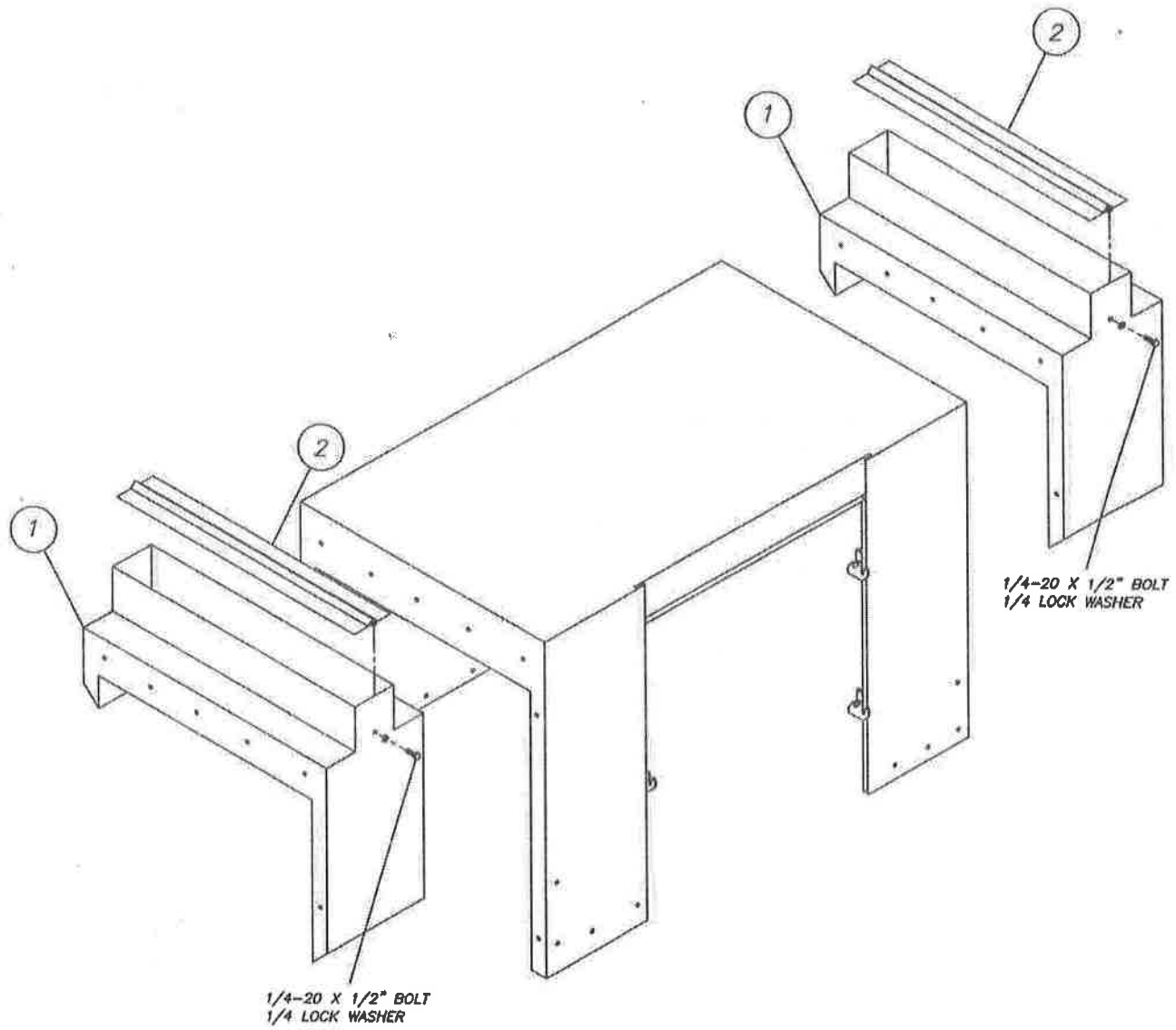



# CURTAINS & RODS

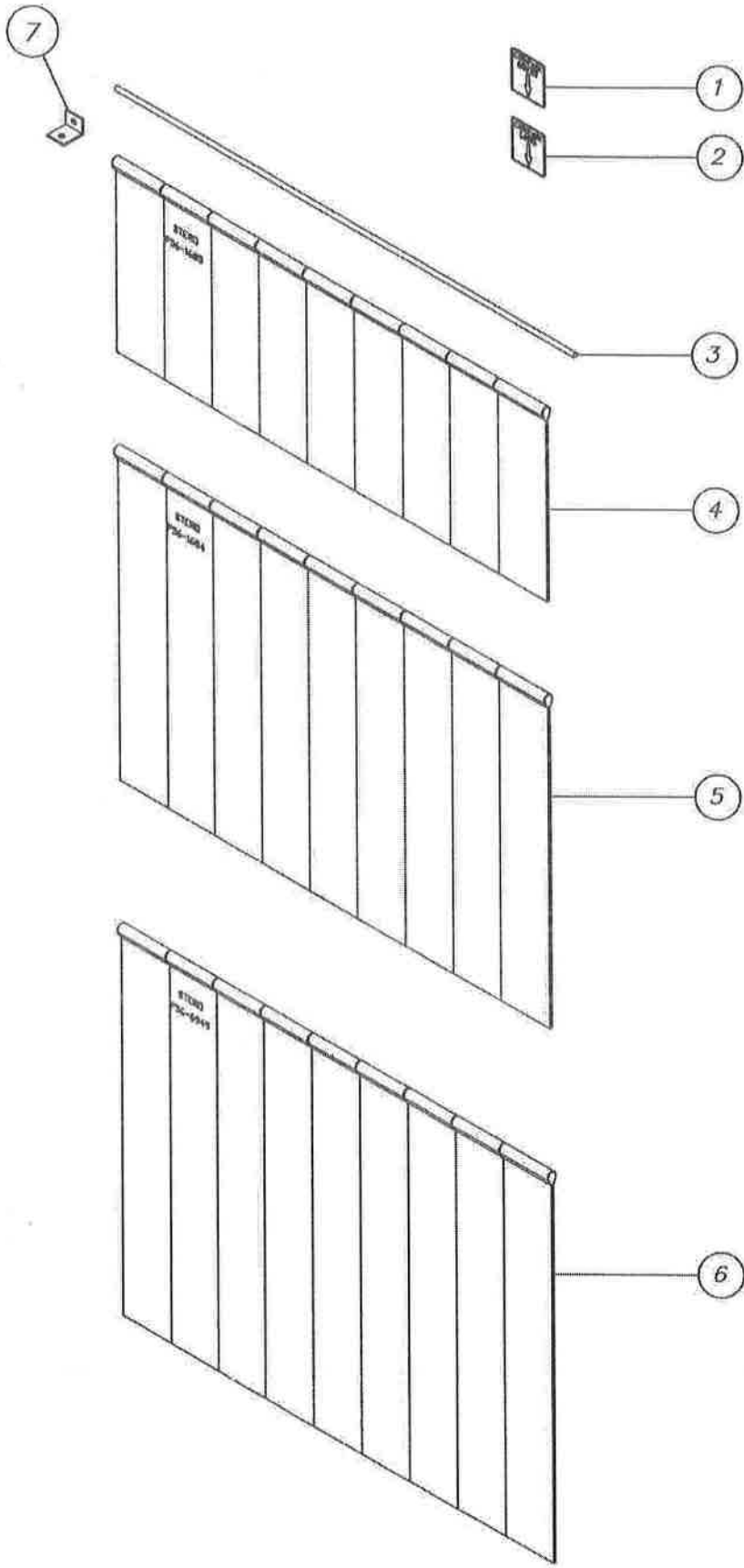

## CURTAINS & RODS

ITEM	DESCRIPTION	REMARKS	QTY	PART#
1	DECAL, CURTAIN SHORT			A69-1974
2	DECAL, CURTAIN LONG			A69-1975
3	ROD, CURTAIN 24-1/8 X 1/4" DIA	STANDARD		A10-2202
	ROD, CURTAIN 22-1/4 X 1/4" DIA SLOTTED	USED WITH HOOD EXTENSIONS		A10-2213
4	CURTAIN, SHORT SIZE "D"	22-5/8 X 9"		P56-1685
5	CURTAIN, LONG SIZE "C"	22-5/8 X 17"		P56-1684
6	CURTAIN, LONG SIZE "E"	22-5/8 X 20"		P56-6949
7	BRACKET, PRISON PACKAGE			A10-5168
NOT SHOWN	CURTAIN, EXTRA LONG (USED ON MACHINES WITH + 6 HOOD HEIGHT)	22-5/8 X 24"		P56-5629
NOT SHOWN	CURTAIN HOOK (WELDED TO MACHINE)			A10-2677
NOT SHOWN	PRISON PACKAGE CURTAIN ROD	STUD WELDED ON AT FACTORY		*A10-2202

# SIDE LOADER PARTS

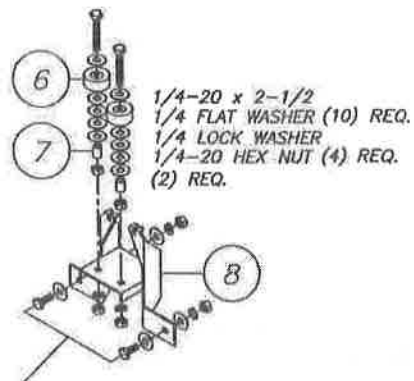
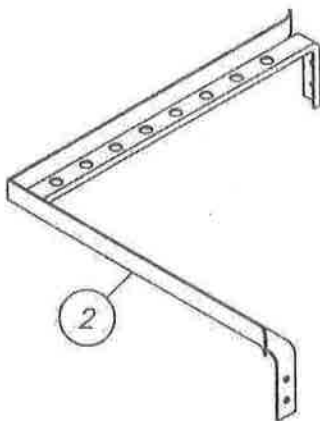
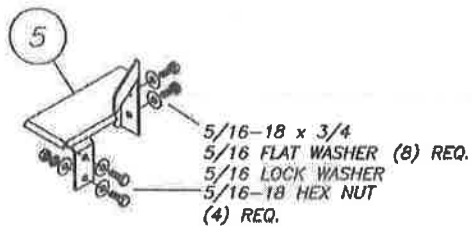
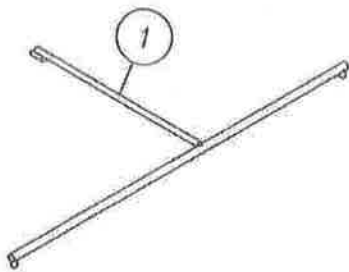

5/16-18 x 7/8  
 5/16 FLAT WASHER (4) REQ.  
 5/16 LOCK WASHER  
 5/16-18 HEX NUT  
 (4) REQ.

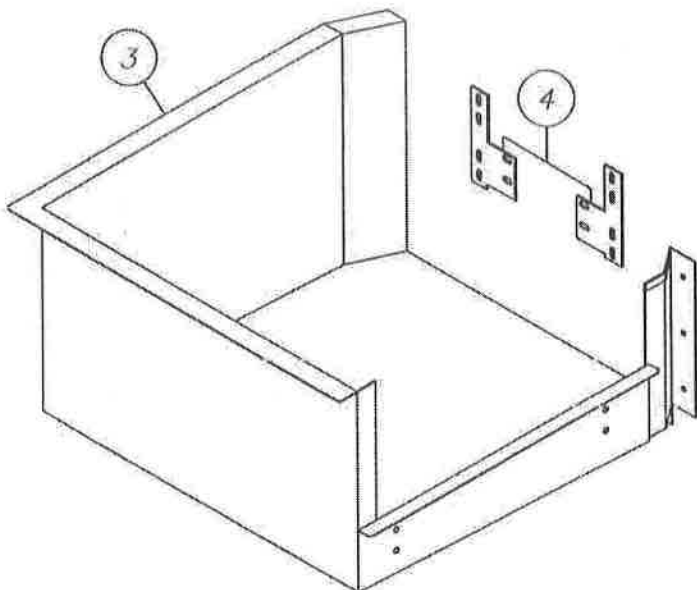

5/16-18 x 1  
 5/16 FLAT WASHER  
 5/16 LOCK WASHER  
 5/16-18 HEX NUT (4) REQ.  
 (2) REQ.

1/16 X 3/8 COTTER PIN  
 1/4 FLAT WASHER

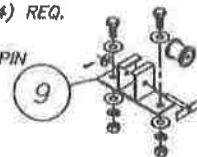



## SIDE LOADER PARTS

ITEM	DESCRIPTION	REMARKS	QTY	PART#
1	BRACKET, RACK SUPPORT L-R	RAC-27		A10-7061
	BRACKET, RACK SUPPORT R-L	RAC-27		A10-7062
	BRACKET, RACK SUPPORT L-R	RAC-32		A10-7065
	BRACKET, RACK SUPPORT R-L	RAC-32		A10-7066
2	TRACK, L-R	RAC-27		B10-7088
	TRACK, R-L	RAC-27		B10-7089
	TRACK, L-R	RAC-32		B10-7092
	TRACK, R-L	RAC-32		B10-7093
3	TANK, SIDE LOADER L-R	RAC-27		B10-7076
	TANK, SIDE LOADER R-L	RAC-27		B10-7077
	TANK, SIDE LOADER L-R	RAC-32		B10-7080
	TANK, SIDE LOADER R-L	RAC-32		B10-7081
4	BRACKET, JOINER	ALL	2	A10-7106
5	SHELF, RACK L-R	RAC-27		A10-7094
	SHELF, RACK R-L	RAC-27		A10-7095
	SHELF, RACK L-R	RAC-32		A10-7098
	SHELF, RACK R-L	RAC-32		A10-7099
6	ROLLER, BELT	ALL	2	A59-1140
7	STANDOFF, .375 DIA .75 LG	ALL	2	A10-2070
8	BRACKET, GUIDE PAWL BAR	ALL		A10-7100
9	ASSYEMBLY, ROLLER BRACKET	ALL		F99-0079
	COMPLETE RAC-27 SIDE LOADER L-R	W/O HOOD		A10-4430
		W/ HOOD		A10-4431
	COMPLETE RAC-27 SIDE LOADER R-L	W/O HOOD		A10-7120
	COMPLETE RAC-32 SIDE LOADER L-R	W/O HOOD		A10-7123
	COMPLETE RAC-32 SIDE LOADER R-L	W/O HOOD		A10-7124

\* TO ORDER, SUPPLY MACHINE MODEL AND SERIAL NUMBER

( 36 )

# 368 PUMP & 2 HP MOTOR

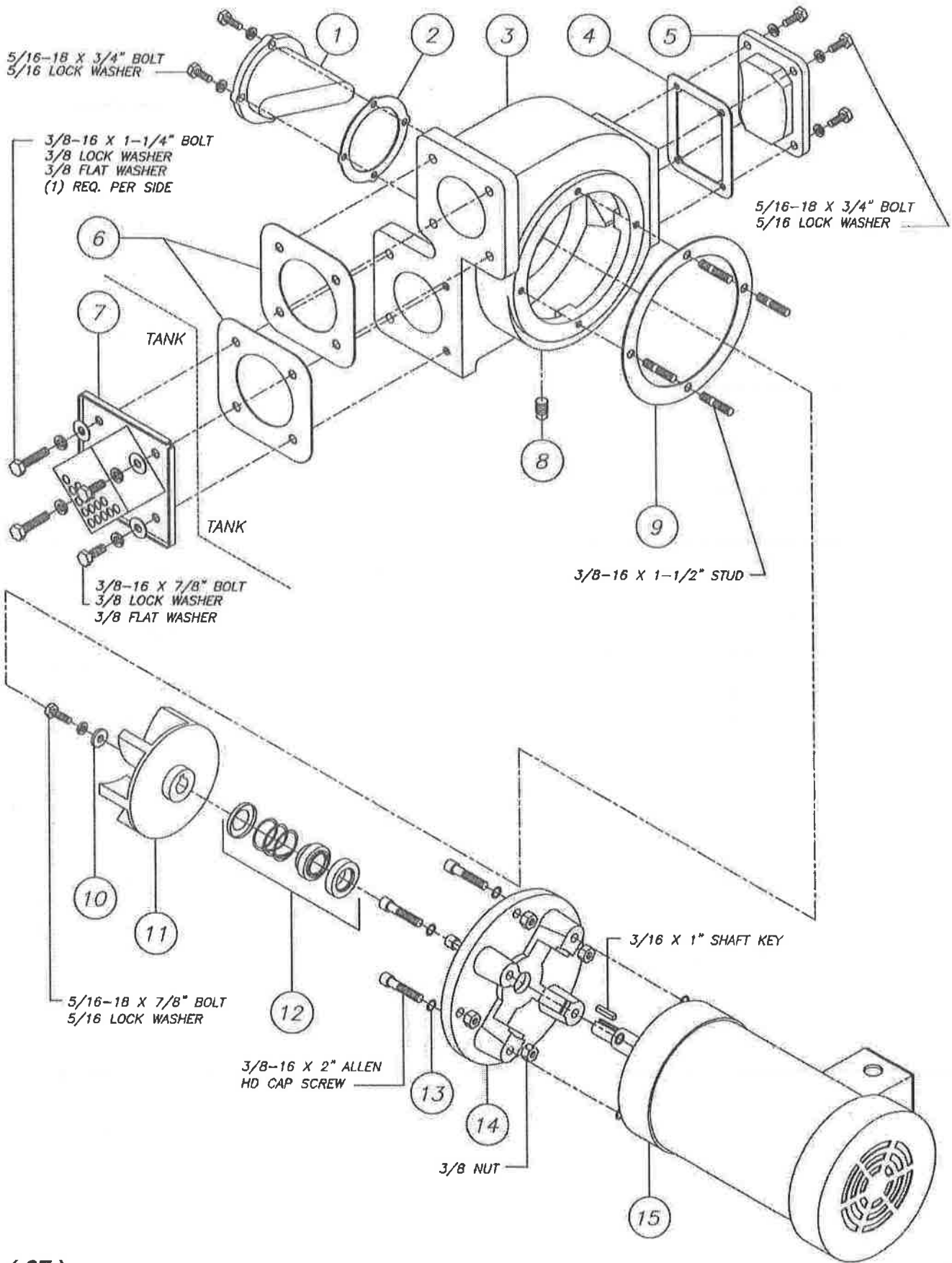

## 368 PUMP & 2 HP MOTOR

ITEM	DESCRIPTION	REMARKS	QTY	PART#
1	COVER, CLEAN OUT #371			A10-1300
2	GASKET "Z1" ROUND INSPECTION COVER			A57-1755
3	PUMP HOUSING #368			C10-1089
4	GASKET "G" 317 INSPECTION COVER			A57-1754
5	COVER, INSPECTION #317			A10-1753
6	GASKET "N" 368 PUMP MOUNTING		2	B57-1757
7	ASSM. PUMP INTAKE SCREEN UNIVERSAL			B10-5763
8	PLUG, BLACK IRON 1/4" MIP			P68-1605
9	GASKET, "Z" MOTOR FLANGE LARGE			B57-1756
10	WASHER, HEAVY FLAT MOTOR END SHAFT TO IMPELLAR			A10-2014
11	IMPELLER SS #375 (2 HORSE)			B10-5488
12	SHAFT SEAL 1"			P57-1697
13	WASHER, SS MOTOR FLANGE		8	P67-1909
14	END BELL #499			C10-1052
15	MOTOR 2HP 208/240/460V 3PH 60HZ			P41-1341
	PUMP HOUSING ASSEMBLY #368 (INCLUDES ITEMS 1,2,3,4,5 & 8) ORDER (2) ITEM #6, (1) ITEM #9	NEED TO		B10-1752
	COMPLETE 2 HP 3 PHASE MOTOR W/ 375 INPELLER ( INCLUDES ITEMS 10-15) ORDER (1) ITEM #9	NEED TO		B10-2179

\* TO ORDER, SUPPLY MACHINE MODEL AND SERIAL NUMBER ( 38 )

# 321 PUMP & 1 HP MOTOR

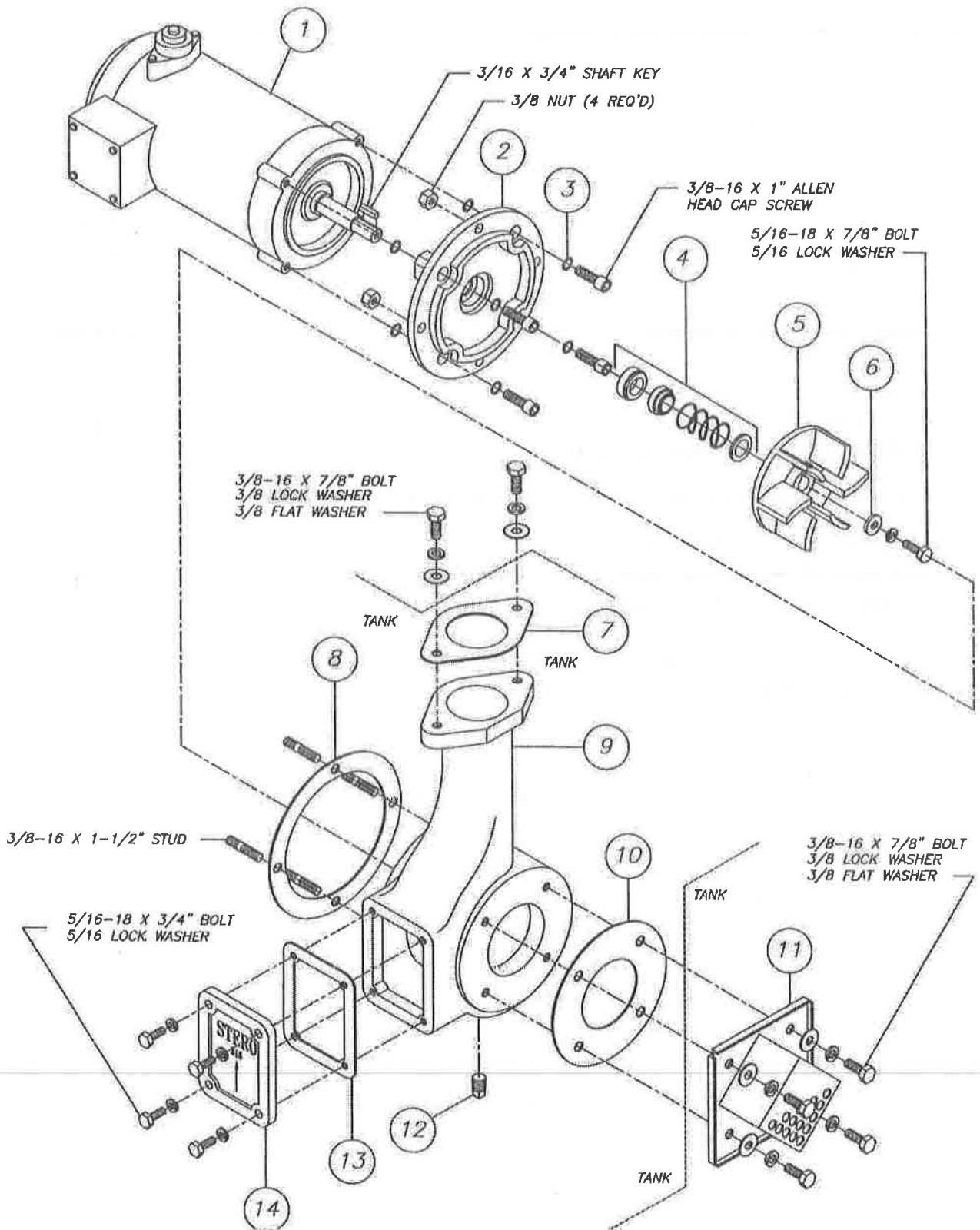

## 321 PUMP & 1 HP MOTOR

ITEM	DESCRIPTION	REMARKS	QTY	PART#
1	MOTOR, 1HP 208/230/460 V. 3PH			P41-2220
	MOTOR, 1 HP 115/230 V. 1PH			P41-2219
2	END BELL, #498A 1 HP TO 1 HP PUMP			C10-2173
	END BELL, #498B 1 HP TO 2 HP PUMP			C10-2175
3	WASHER, S/S MOTOR FLANGE		8	P67-1909
4	SEAL, SHAFT 3/4"			P57-1696
5	IMPELLER, #307 S/S			B10-5490
6	WASHER, HEAVY FLAT MOTOR END SHAFT TO IMPELLER			A10-2014
7	GASKET, "T" 321 PUMP DISCHARGE			B57-2444
8	GASKET, "L" MOTOR TO PUMP			B57-2443
9	HOUSING, PUMP #321			C10-2440
10	GASKET, "S" PUMP SUCTION FLANGE			B57-2442
11	SCREEN, PUMP INTAKE UNIVERSAL			B10-5763
12	PLUG, 1/4" NPT			P68-1605
13	GASKET, "G" 316 & 317 INSPECTION COVER			A57-1754
14	COVER, INSPECTION #316			A10-2441
	COMPLETE 3 PHASE MOTOR WITH IMPELLER ( ASSEMBLY INCLUDES ITEMS 1 THRU 6 & MISC HARDWARE)	NEED TO ORDER (1) ITEM # 7, 8 & 10		B10-4171
	COMPLETE 1 PHASE MOTOR WITH IMPELLER (ASSEMBLY INCLUDES ITEMS 1 THRU 6 & MISC. HARDWARE)	NEED TO ORDER (1) ITEM # 7, 8 & 10		B10-2185
	PUMP COMPLETE #321 (ASSEMBLY INCLUDES ITEMS 9,12,13 & 14)			B10-2479

\* TO ORDER, SUPPLY MACHINE MODEL AND SERIAL NUMBER ( 40 )

# MOTOR & GEAR BOX DRIVE ASSEMBLY

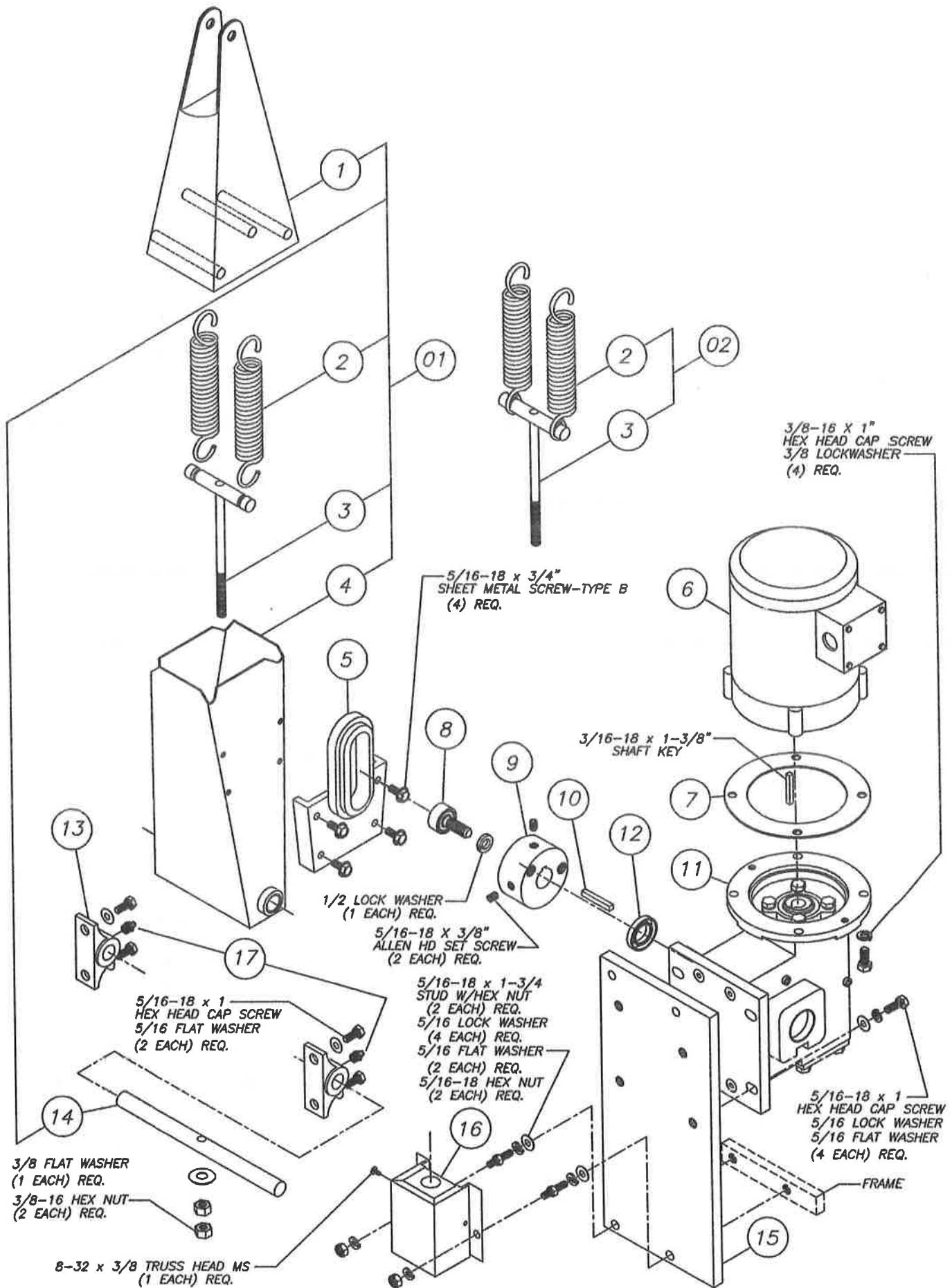

# MOTOR & GEAR BOX DRIVE ASSEMBLY

ITEM	DESCRIPTION	REMARKS	QTY	PART#
01	ASSY, COMPLETE CONVEYOR RELEASE HOUSING	INCLUDES ITEMS: 1, 2, 3, 4 & 14		B10-1940
02	ASSY, CONVEYOR RELEASE SPRING/TENSION BAR	INCLUDES ITEMS: 2 & 3		B10-6243
1	HOUSING, RELEASE UPPER HALF			A10-1942
2	SPRING, CONVEYOR RELEASE		2	A60-1104
3	BAR, TENSION CONVEYOR RELEASE			A10-1234
4	HOUSING, RELEASE LOWER HALF			A10-1941
5	FOLLOWER, DRIVE ARM - ECCENTRIC CAM	CASTING # 1104		A10-1948
6	MOTOR, 1/4 HP 208/230/460 V. 3 PH.			P41-2218
7	GASKET, CONVEYOR MOTOR/GEAR BOX			A57-1020
8	BEARING, CONVEYOR ECCENTRIC & IDLER WHEEL			P66-6337
9	ECCENTRIC, CONVEYOR DRIVE			B10-1304
10	KEY, SHAFT 1/4" STAINLESS STEEL			P50-1338
11	GEAR BOX 71:1 LEFT HAND	SHOWN		P58-1216
	GEAR BOX 71:1 RIGHT HAND			P58-1215
	GEAR BOXES USE SAE 90 WT. OIL			
12	SEAL, OUTPUT SHAFT (WINDSMITH)			P57-5899
13	BEARING, JOURNAL W/FITTING		2	A10-1939
14	SHAFT, CROSS CONVEYOR RELEASE			A10-1233
15	PLATE, GEAR BOX MOUNTING			B10-1949
16	BOX, TABLE LIMIT SWITCH CONNECTION POINT			A10-6312
17	FITTING, ZIRK FOR JOURNAL BEARING			P66-1221

\* TO ORDER, SUPPLY MACHINE MODEL AND SERIAL NUMBER ( 42 )

# STRAIGHT DRIVE SECTION ASSEMBLY

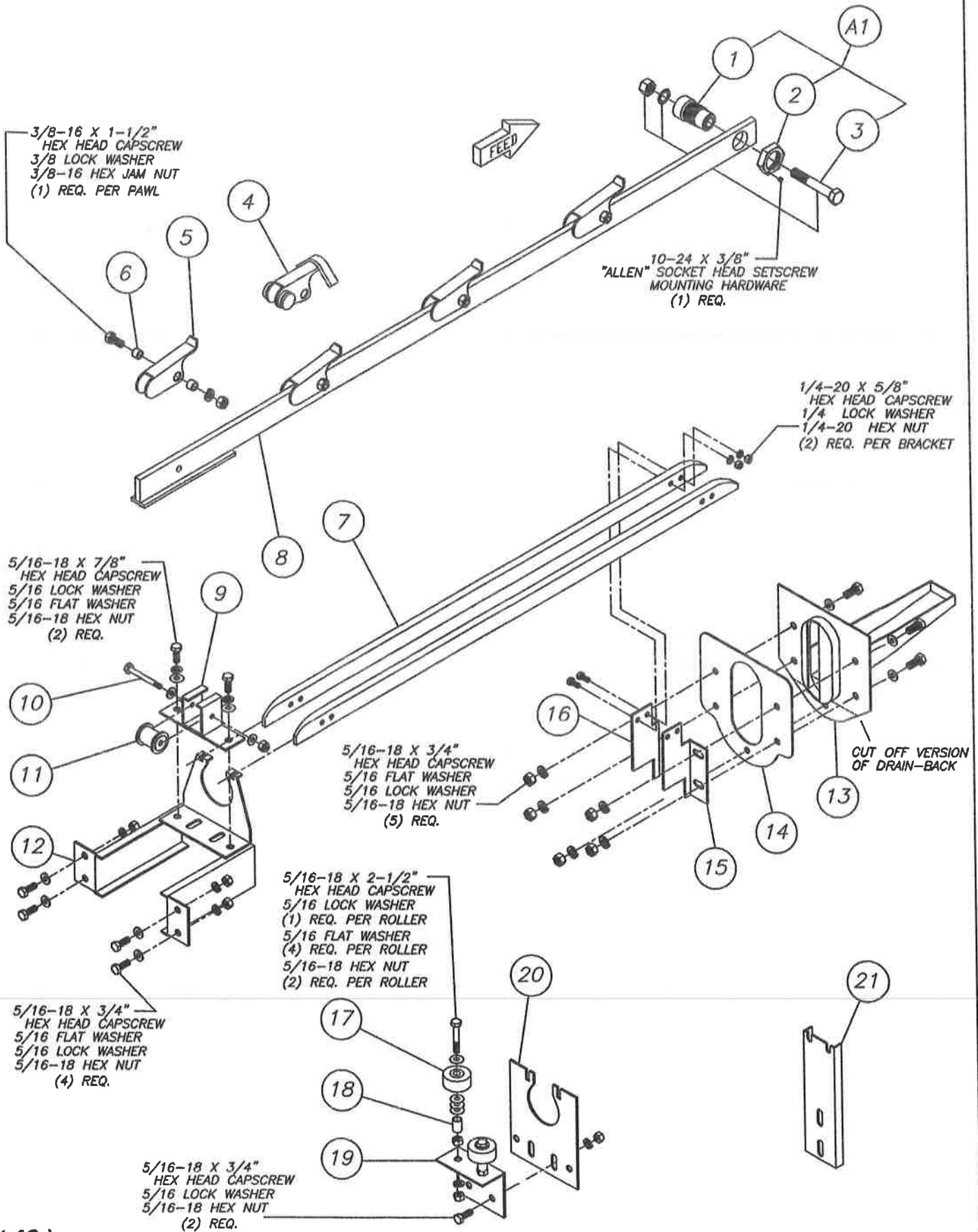



## STRAIGHT DRIVE SECTION ASSEMBLY

ITEM	DESCRIPTION	REMARKS	QTY	PART#
A1	COUPLING ASSY W/RUBBER INSERT	INCLUDES 1-2-3		A10-1943
1	CONVEYOR BAR BEARING WITH INSERT			A10-2637
2	LOCKNUT, CONVEYOR BAR BEARING			A10-1213
3	MNTG. HARDWARE, CONVEYOR BAR PIVOT BRNG.			P67-2078
4	PAWL CORNER	CORNER SCRAPPERS, SIDELOADER, EXTENDED PAWL BAR		B10-1274
5	PAWL CONVEYOR DRIVE STAND			B10-1273
6	PAWL BUSHING S.S.			A51-1095
7	GUIDE RAIL	ER-44	2	B10-2720
	GUIDE RAIL	ER-64	2	B10-2604
	GUIDE RAIL	ER-66S	2	B10-2721
	GUIDE RAIL	ER-76S(SC)	2	B10-2605
	GUIDE RAIL	ER-86S(SC)	4	B10-2605
	GUIDE RAIL	ER-94S(SC)	4	B10-2605
8	PAWL BAR	ER-44		B10-1944
	PAWL BAR	ER-64		B10-2598
	PAWL BAR	ER-66S		B10-1272
	PAWL BAR	ER-76S (SC)		B10-2599
	PAWL BAR (BAR CUT TO SIZE)	ER-86S (SC), ER-94S (SC)		* B10-2603
9	BRCKT CONVYR ROLLER ASMBLY			A10-1280
10	MNTG. HARDWARE, CONVEYOR ROLLER			A10-1281
11	ROLLER, CONVEYOR BAR			A59-1202
12	BRCKT ASSY W/RLLR & RAIL YK LG			B10-3684
13	DRAIN BACK CONV DRIVE TRIMMED			A10-6733
14	GASKET "Q" DRAIN-BACK			A57-2079
15	BRCKT GUIDE RAIL SUPPORT L-H			A10-1946
16	BRCKT GUIDE RAIL SUPPORT R-H			A10-1947
17	BELT ROLLERS UHMW			A59-1140
18	SPACER STAND-OFF LEGS			A10-2070
19	BRACKET, CENTER SUPPORT ROLLER			B10-2610
20	BRACKET, CENTER SUPPORT YOKE			B10-2609
21	BRACKET, SUPPORT TRACK CTR			A10-4550

\* TO ORDER, SUPPLY MACHINE MODEL AND SERIAL NUMBER ( 44 )

# TRACKS

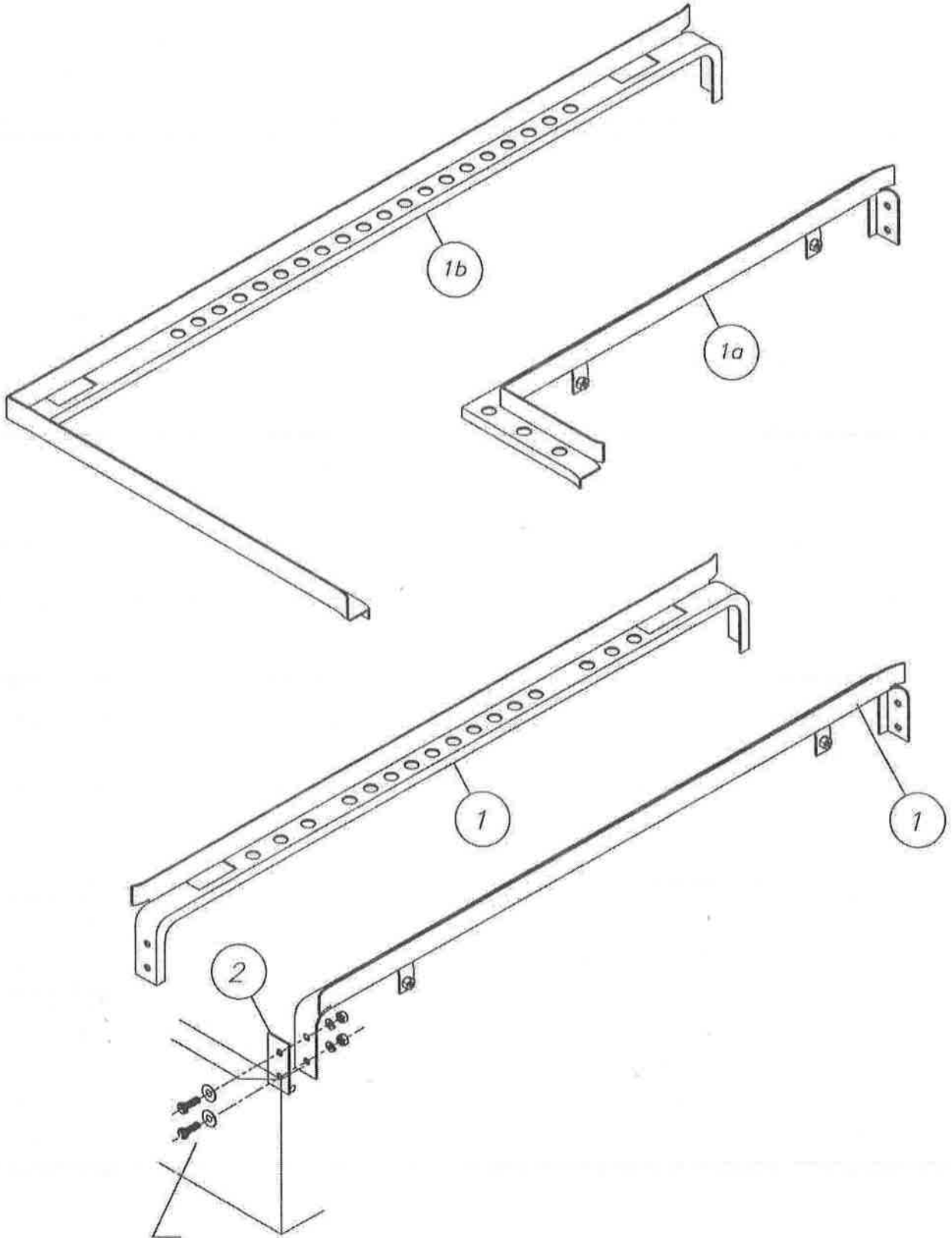

5/16-18 x 7/8  
5/16 FLAT WASHER  
5/16 LOCK WASHER  
5/16-18 HEX NUT  
(4) REQ. PER SIDE



# START & RINSE LEVER ASSEMBLIES

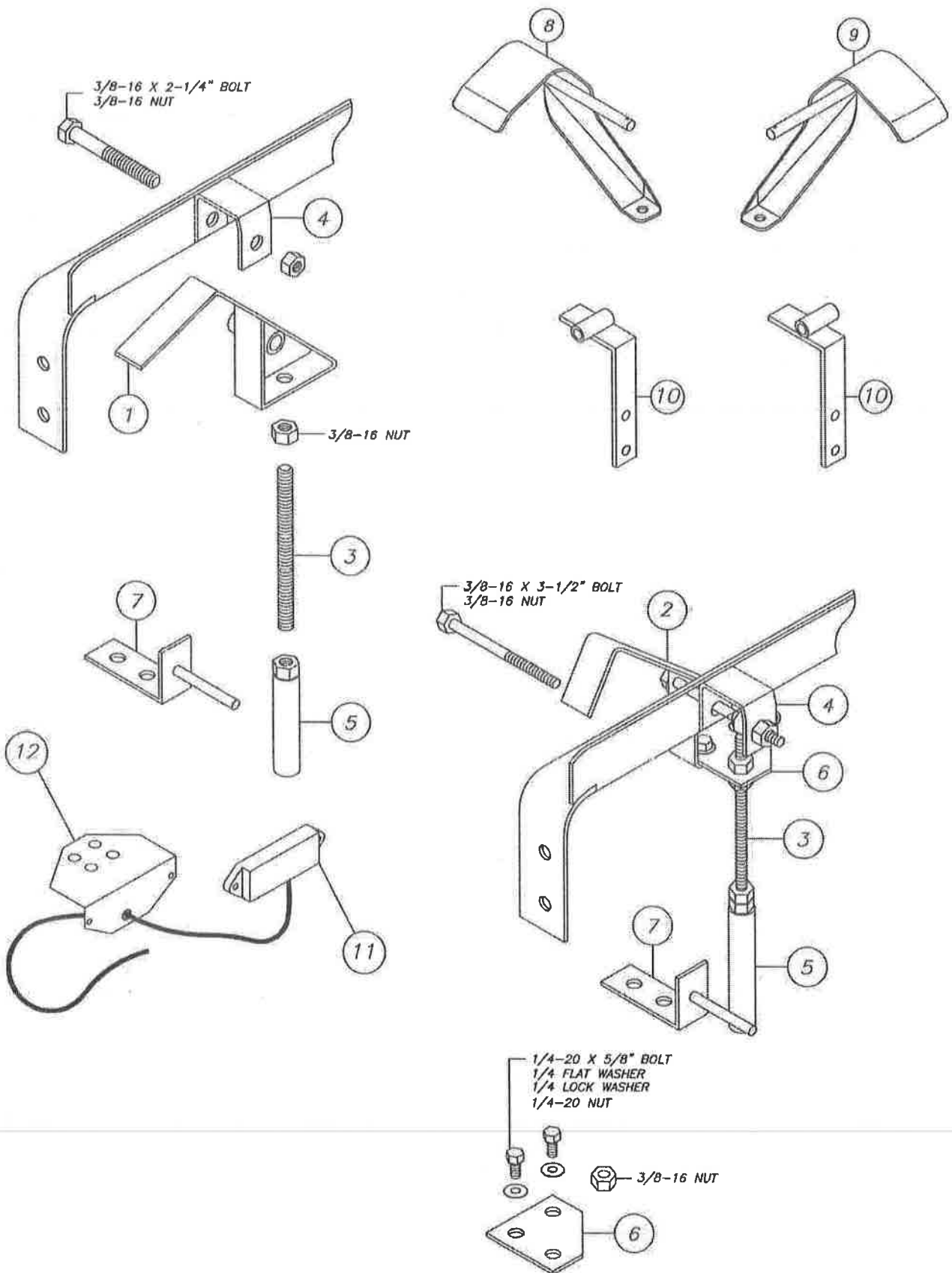

## START & RINSE LEVER ASSEMBLIES

ITEM	DESCRIPTION	REMARKS	QTY	PART#
1	LEVER,AUTO START 65 DEGREE			B10-1980B
2	LEVER,FINAL RINSE 90 DEGREE			B10-1980A
3	STUD, S.S. 3/8-16 X 2-1/4"			A67-2388
	STUD, S.S. 3/8-16 X 3-1/4"			A67-2065
	STUD, S.S. 3/8-16 X 4-5/8"			A67-2064
	STUD, S.S. 3/8-16 X 5-1/2"			A67-2390
4	BRCKT PVT RACK SWTCH ASSY LVR			A10-1976
5	MAGNET, ASSY RACK SENSING			A10-1585
6	LEVER, STUD RETAINER			A10-5269
7	START SWITCH POST SUPPORT			A10-5270
8	LEVER, START SWITCH L-R	W/CORNER SCRAPPER		B10-3310
9	LEVER, START SWITCH R-L	W/CORNER SCRAPPER		B10-3312
10	BRACKET, MOUNTING START PAWL (L-R OR R-L)	W/CORNER SCRAPPER		*A10-3831
11	SWITCH, REED WITH SJ CORD			B10-5595
12	BRACKET, MOUNTING REED SWITCH			A10-4273

\* TO ORDER, SUPPLY MACHINE MODEL AND SERIAL NUMBER ( 48 )

# SCRAPPER TANK SPRAY ASSEMBLY

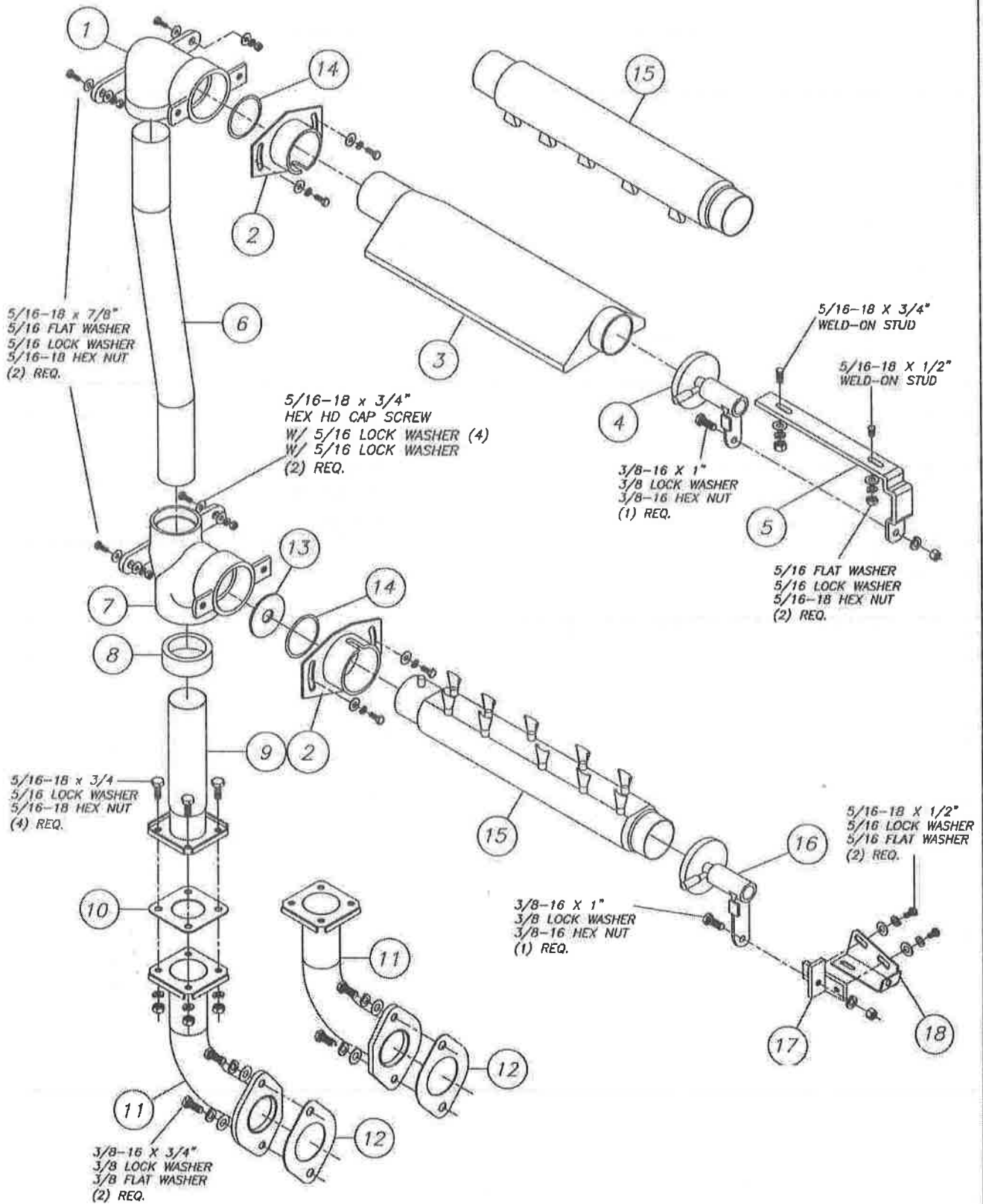

## SCRAPPER TANK SPRAY ASSEMBLY

ITEM	DESCRIPTION	REMARKS	QTY	PART#
1	CASTING ELBOW SUPPLY MANIFOLD			P44-6452
2	ADAPTOR, MANIFOLD			B10-2250
3	MANIFOLD 18 SPRY UPR SCRAPPER	22" SCRAPPER		C10-1045
4	ASSY MANIFOLD QUICK RELEASE TOP			B10-6355
5	BRCKT QUICK RELEASE TOP			A10-6429
6	SCRAPPER RISER TUBE	*		A10-2275
7	CASTING TEE COMBO SUPPLY MANIFOLD			P44-6451
8	BUSHING SCRAPPER TEE			A10-6673
9	TUBE, SCRAPPER MANIFOLD RISER			A10-2270
10	SCRAPPER MANIFOLD RISER GASKET			A57-1114
11	TUBE ASSY DISCH SCRPPR PUMP*	LEFT TO RIGHT		B10-1186A
	TUBE ASSY DISCH SCRPPR PUMP*	RIGHT TO LEFT		B10-1186B
12	GASKET T 321 PUMP DISCHARGE			B57-2444
13	RESTRCTR FLW SPRY MANIF S/S 1"	10 SPRAYERS		A10-2253
14	O RING #228 VITON MANFLD ADAPT			P57-2519
15	MANIFOLD 10 SPRY LWR SCRAPPER			B10-2258
	MANIFOLD 10 SPRY UPPER SCRAPPER	30" SCRAPPERS		B10-2258
16	ASSY MANIFOLD QUICK RELEASE BOTTOM			B10-6356
17	BRCKT QUICK RELEASE ADJUSTABLE MTG			A10-6706
18	BRCKT QUICK RELEASE BOTTOM ER BASE MTG			A10-6441

\* TO ORDER, SUPPLY MACHINE MODEL AND SERIAL NUMBER ( 50 )

# CORNER SCRAPER TANK SPRAY ASSEMBLY

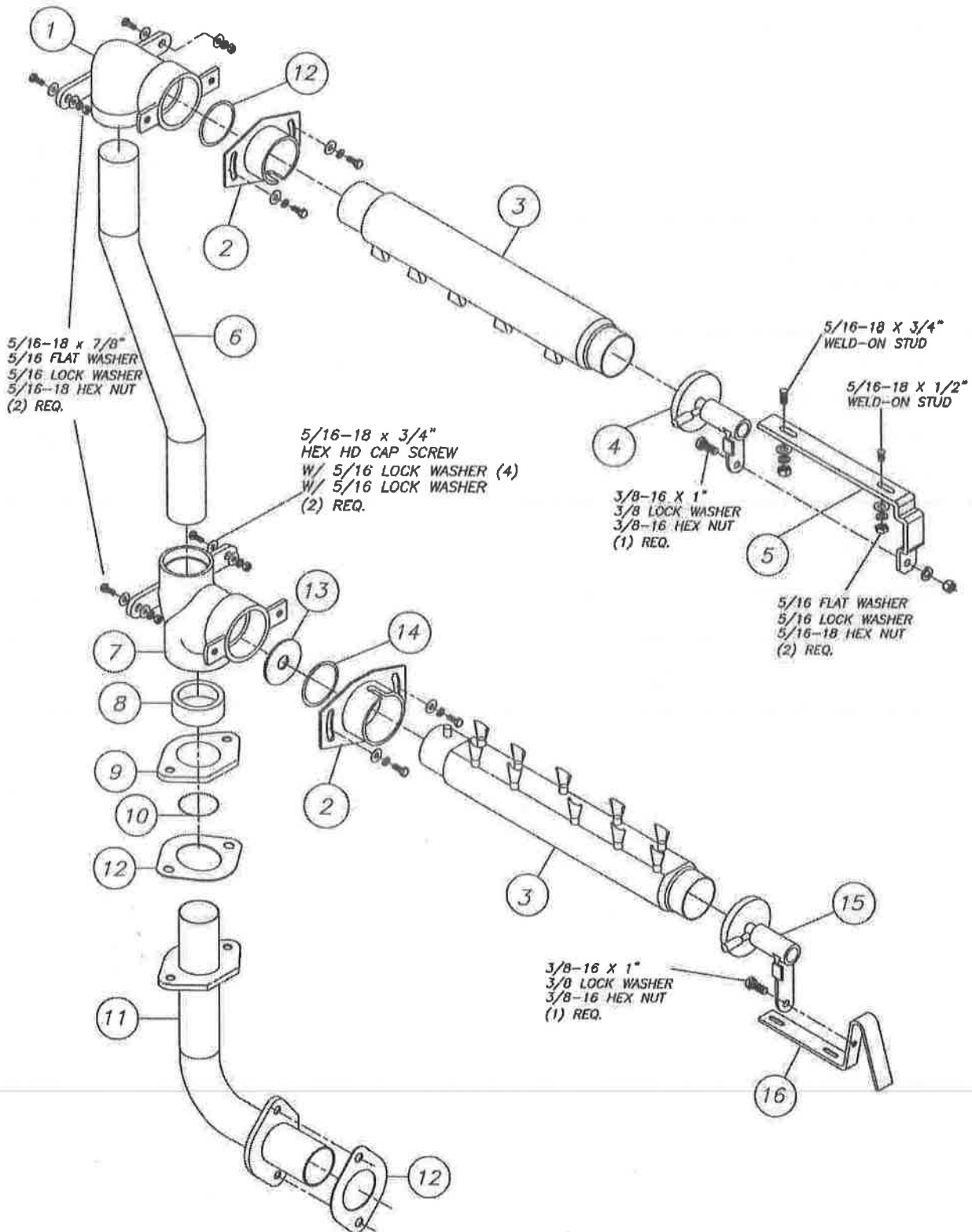



## CORNER SCRAPPY TANK SPRAY ASSEMBLY

ITEM	DESCRIPTION	REMARKS	QTY	PART#
1	CASTING ELBOW SUPPLY MANIFOLD			P44-6452
2	ADAPTOR, MANIFOLD			B10-2250
3	MANIFOLD 10 SPRY UPP & LWR SCRAPPY			B10-2258
4	ASSY MANIFOLD QUICK RELEASE TOP			B10-6355
5	BRCKT QUICK RELEASE TOP			A10-6429
6	SCRAPPY RISER TUBE	*		A10-4808
7	CASTING TEE COMBO SUPPLY MANIFOLD			P44-6451
8	BUSHING SCRAPPY TEE			A10-6673
9	ADAPTOR PIPE FLANGE 2"			B10-1506
10	O-RING, #327 VITON			P57-1057
11	PIPE CARRYOVER PMP-MANIF SCRAPPY			B10-1991
12	GASKET 321 PUMP DISCHARGE			B57-2444
13	RESTRCTR FLW SPRY MANIF S/S 1"	10 SPRAYER		A10-2253
14	O RING #228 VITON MANFLD ADAPT			P57-2519
15	ASSY MANIFOLD QUICK RELEASE BOTTOM			B10-6356
16	BRCKT, QUICK RELEASE BOTTOM CORNER			A10-6433

\* TO ORDER, SUPPLY MACHINE MODEL AND SERIAL NUMBER ( 52 )

# WASH/RINSE SPRAY ASSEMBLY

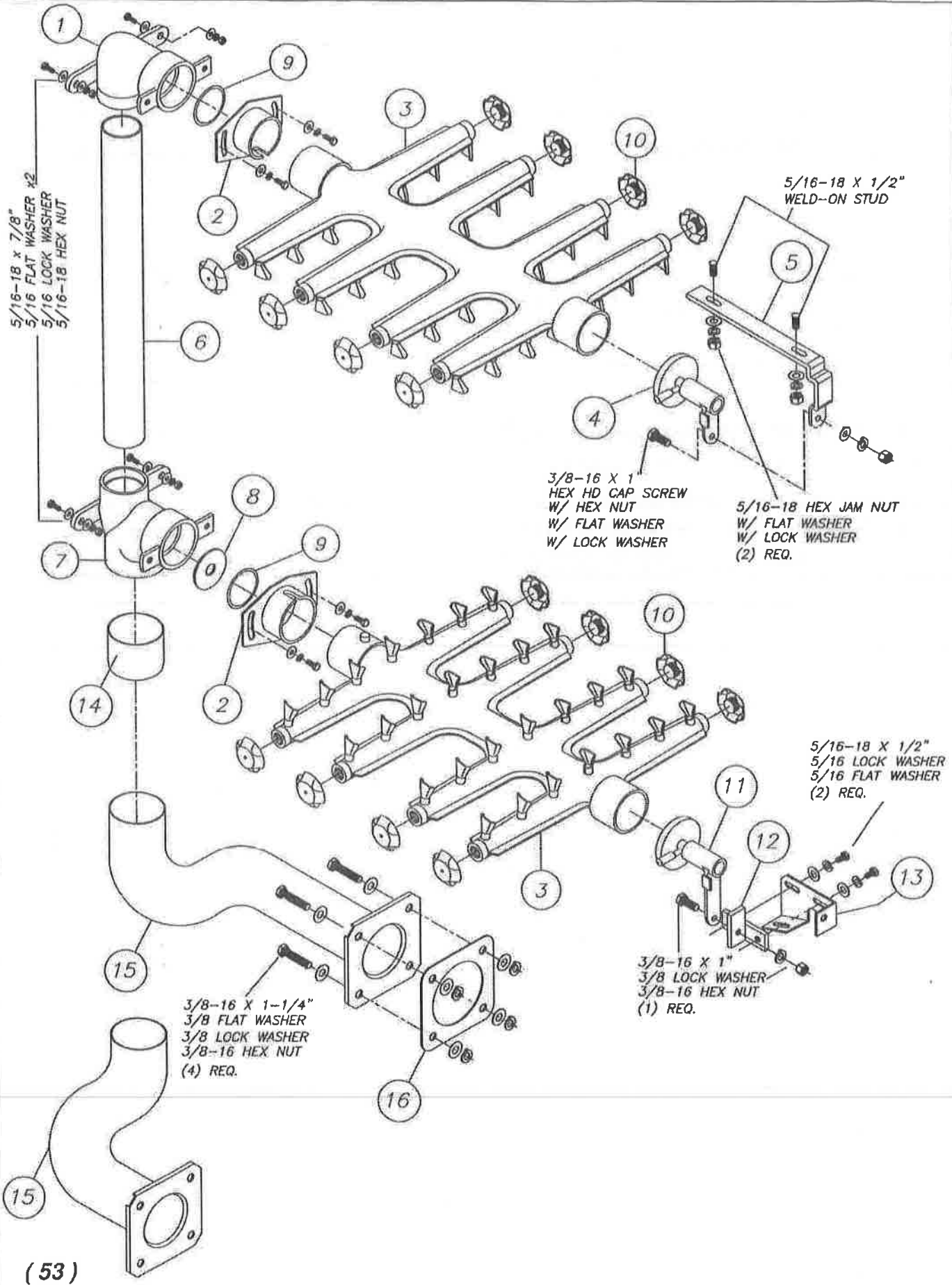

## WASH/RINSE SPRAY ASSEMBLY

ITEM	DESCRIPTION	REMARKS	QTY	PART#
1	CASTING ELBOW SUPPLY MANIFOLD			P44-6452
2	ADAPTOR, MANIFOLD			B10-2250
3	MANIFOLD, CENTER FED (28 SPRAYERS)	ER-44, ER-66S (SC), ER-76S (SC)		C10-1259
	MANIFOLD, CENTER FED (20 SPRAYERS)	ER-64, ER-86S (SC), ER-94S (SC)		C10-1162
4	ASSY MANIFOLD QUICK RELEASE TOP			B10-6355
5	BRCKT QUICK RELEASE TOP			A10-6429
6	STANDPIPE 2 X 24-3/16	STD HOOD		* A10-4335
	STANDPIPE 2 X 21-3/16	OLD STD		* A10-1994
	STANDPIPE 2 X 27-3/16	3" RAISED HOOD		* A10-4365
7	CASTING TEE COMBO SUPPLY MANIFOLD			P44-6451
8	RESTRCTR FLW SPRY MANIF 1-1/2	28 SPRAYERS		A10-2256
	RESTRCTR FLW SPRY MANIF 1-1/4	20 SPRAYERS		A10-2255
9	O RING #228 VITON MANFLD ADAPT			P57-2519
10	CAP ASSY NEW STY TREE MANIF			A10-3318
11	ASSY MANIFOLD QUICK RELEASE BTM			B10-6356
12	BRCKT Q/R ADJUSTABLE MTG			A10-6706
13	BRCKT Q/R BOTTOM ER BASE MTG			A10-6707
14	CROSSOVER TUBE RISER, 2 1/4" LONG	ER-44, ER-66S (SC), ER-76S (SC)		A10-6918
	CROSSOVER TUBE RISER, 3 1/4" LONG	ER-64, ER-86S (SC), ER-94S (SC)		A10-6920
15	CROSSOVER SUPPLY TUBE ER-44	ER-44, ER-66S (SC), ER-76S (SC)		A10-6978
	TUBE CROSSOVER SUPPLY MAN 2G	ER-64, ER-86S (SC), ER-94S (SC)		A10-6565
16	GASKET, CROSSOVER TUBE			B57-1757

\* TO ORDER, SUPPLY MACHINE MODEL AND SERIAL NUMBER ( 54 )

# FINAL RINSE ASSEMBLY

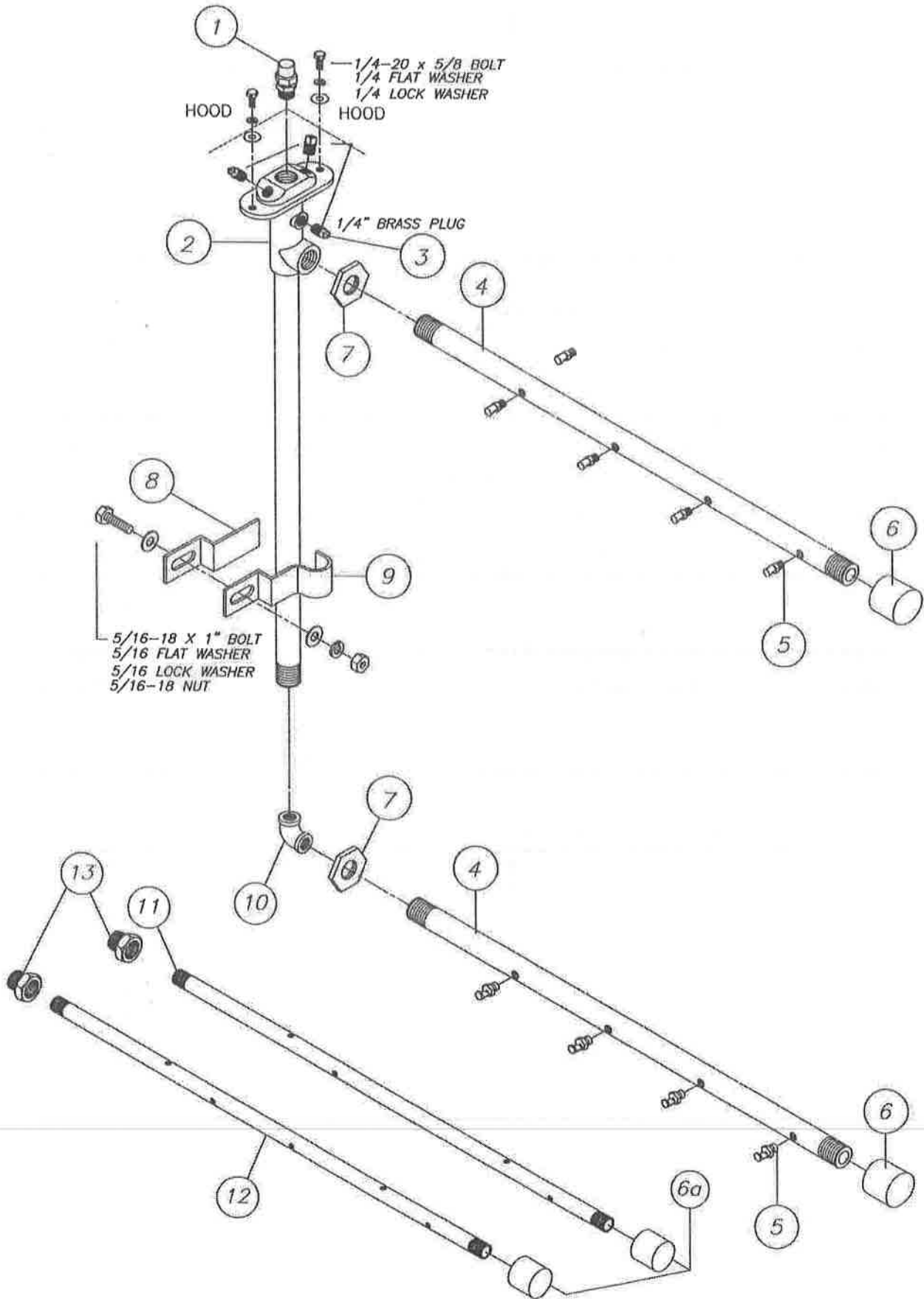

## FINAL RINSE ASSEMBLY

ITEM	DESCRIPTION	REMARKS	QTY	PART#
1	UNION, 1/2 CXM CAST			P68-6646
2	STANDPIPE, TEE ASSEMBLY FINAL RINSE	21-1/8" (OLD STANDARD)		* A10-6755
	STANDPIPE, TEE ASSEMBLY FINAL RINSE	24-1/8" (ER-44 & NEW MULTI TANK STANDARD)		* A10-6756
	STANDPIPE, TEE ASSEMBLY FINAL RINSE	27-1/8" (RAISED HOOD)		* A10-6757
3	PLUG, 1/4" BRASS			P68-1489
4	PIPE, FINAL RINSE S.S. 18-1/2" 4 HOLE	ER-44,ER-66S & ER-76S(SC)		B10-2680
5	JET, .055 S.S. FAN TYPE	ER-44,ER-66S & ER-76S(SC)		A10-6409
	JET, .063 S.S. FAN TYPE	ER-64,ER-86S & ER-94S(SC)		B50-1173
6	CAP, CPVC 1/2" FIP			P68-1293
6a	CAP, CPVC 3/8" FIP			P68-7142
7	NUT, LOCK S.S. 1/2" NPT			A10-1446
8	BRACKET, RISER PIPE S.S.			A10-3721
9	CLAMP, RISER PIPE S.S.			A10-3722
10	ELBOW 90° 1/2" S.S. FIP			P68-1887
11	PIPE, FINAL RINSE S.S. 19" 4 HOLE. BOTTOM	ER-64,ER-86S & ER-94S(SC)		A10-6599
12	PIPE, FINAL RINSE S.S. 19" 5 HOLE. TOP	ER-64,ER-86S & ER-94S(SC)		A10-6597
13	BUSHING, S.S. 1/2" X 3/8" MXF			P68-6651

\* TO ORDER, SUPPLY MACHINE MODEL AND SERIAL NUMBER ( 56 )

# TANK HEAT

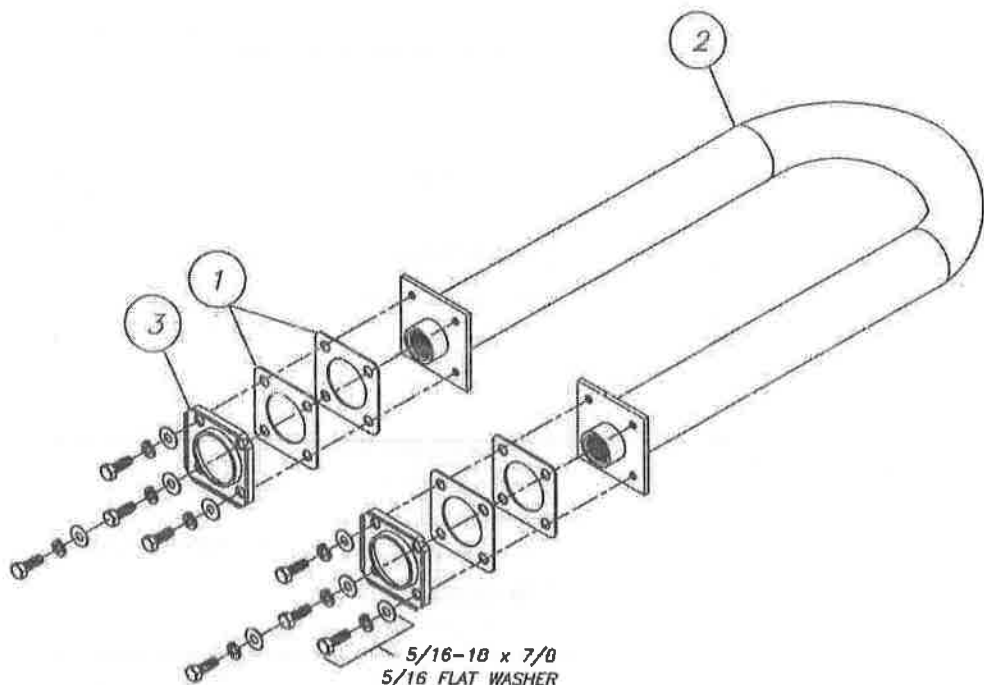

5/16-18 x 7/0  
5/16 FLAT WASHER  
5/16 LOCK WASHER  
(4) REQ. PER SIDE

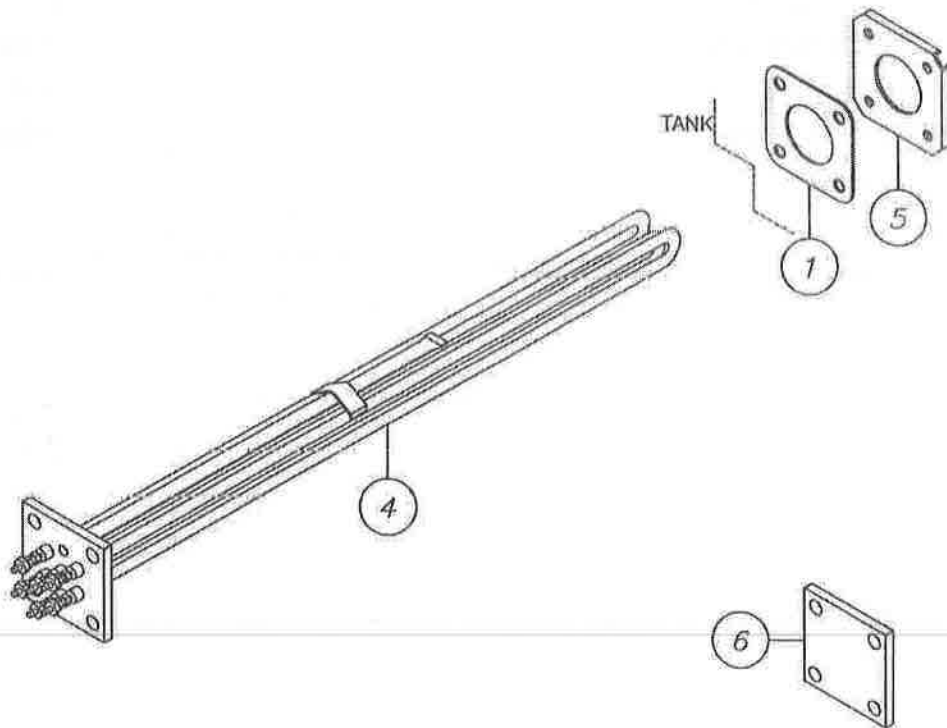

## TANK HEAT STEAM AND ELECTRIC

ITEM	DESCRIPTION	REMARKS	QTY	PART#
1	GASKET U FLANGE HEATER			A57-1114
2	STEAM COIL, WASH/RINSE 18-1/2"			A10-4395
3	FLANGE ADAPTOR			B10-1505
4	ELEMENT, HEATING 5KW 208V			P55-1131
	ELEMENT, HEATING 5KW 480V			P55-1133
5	FLANGE, HEATING ELEMENT			B10-1502
6	PLATE , BLANK 3X3 S/S			A10-3326

\* TO ORDER, SUPPLY MACHINE MODEL AND SERIAL NUMBER ( 58 )

# HEAT ENCLOSURES & HIGH LIMIT

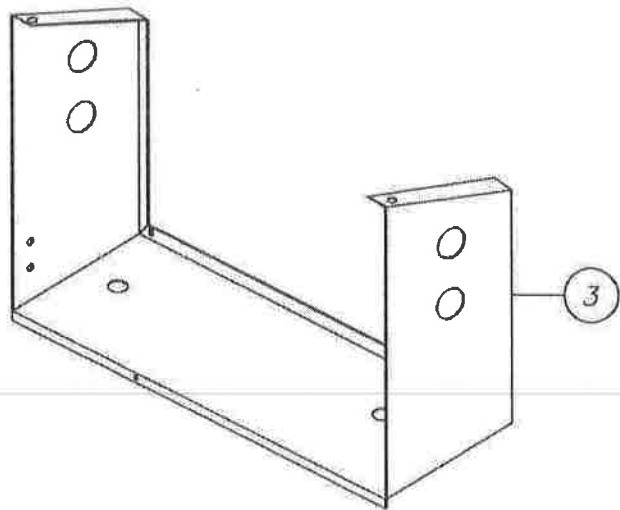
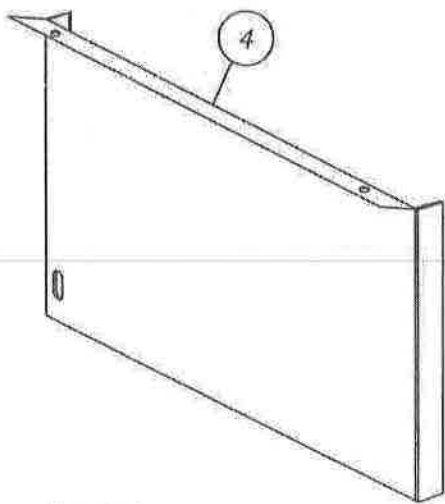
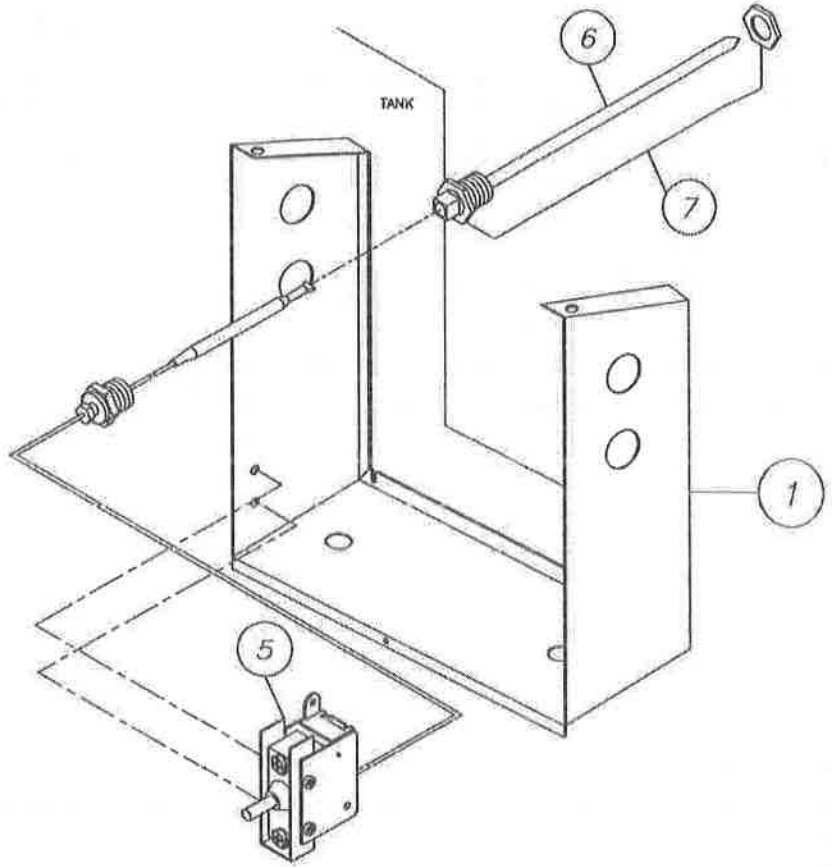
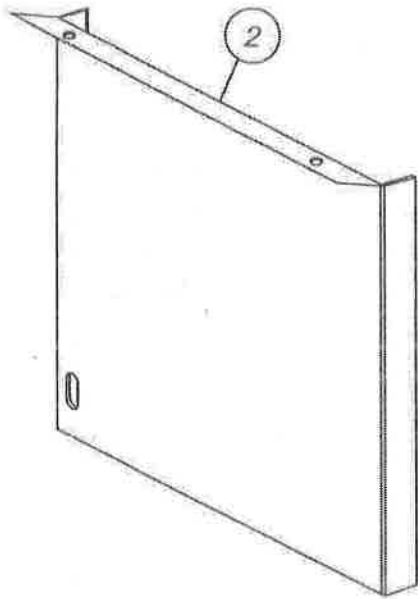





# STEAM BOOSTERS

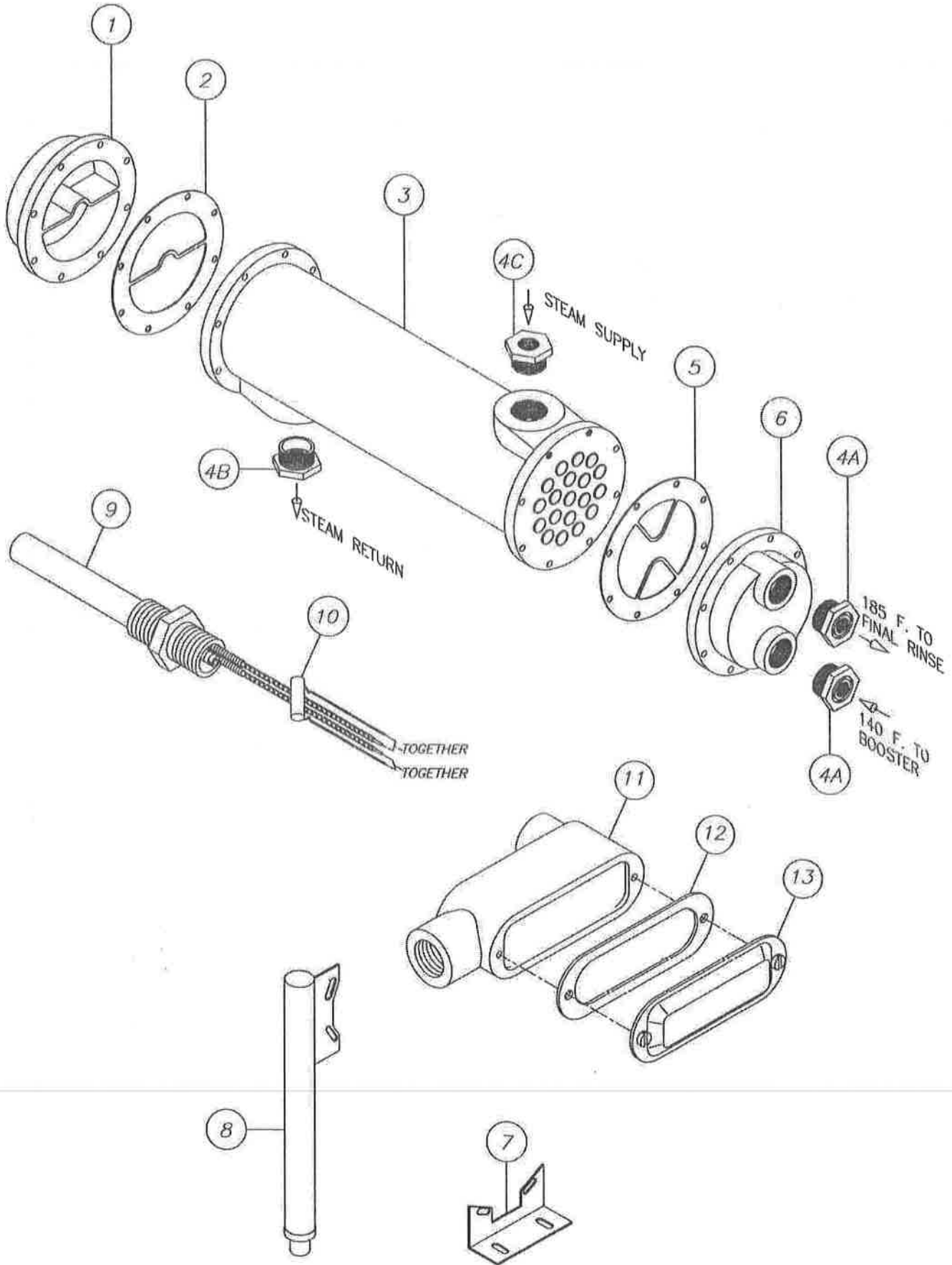

## STEAM BOOSTERS

ITEM	DESCRIPTION	REMARKS	QTY	PART#
1	HEADER, THERMOSTAT END	SWB-180		P64-1964
	HEADER, THERMOSTAT END	SWB-260 THRU 380		C10-2238
2	GASKET, RETURN END	SWB-180		B57-1278
	GASKET, RETURN END	SWB-260 THRU 380		B57-2236
3	HEAT EXCHANGER SWB-180	ITEMS 1-3, 5 & 6		P64-1960
	HEAT EXCHANGER SWB-260	ITEMS 1-3, 5 & 6		P64-1961
	HEAT EXCHANGER SWB-320	ITEMS 1-3, 5 & 6		P64-1962
	HEAT EXCHANGER SWB-380	ITEMS 1-3, 5 & 6		P64-1963
4A	BUSHING GALV. 1-1/4 X 3/4 MXF	SWB-180	2	P68-1563
	BUSHING GALV. 2 X 3/4 MXF	SWB-260 THRU 380	2	P68-1610
4B	BUSHING B.I. 1-1/2 X 1/2 MXF	SWB-180		P68-1562
	BUSHING B.I. 2 X 3/4 MXF	SWB-260 THRU 380		P68-1608
4C	BUSHING B.I. 1-1/2 X 3/4 MXF	SWB-180		P68-1561
	BUSHING B.I. 2 X 1-1/4 MXF	SWB-260 THRU 380		P68-1607
5	GASKET, FLOW END	SWB-180		B57-2234
	GASKET, FLOW END	SWB-260 THRU 380		B57-2235
6	HEADER, FLOW END	SWB-180		P64-1965
	HEADER, FLOW END	SWB-260 THRU 380		P64-1966
7	BRACKET, MACHINE MOUNTING			A10-3225
8	LEG, FLOOR MOUNTED			A10-3350
9	THERMOSTAT, CONTACTS OPEN ON RISE			P65-1183
10	CAPACITOR, .001-600V	MUST USE WITH P65-1183		P41-2462
11	UNILET BODY (USED WITH P65-1183)			P52-2014
12	GASKET, 1/2" NEO			P52-2018
13	COVER, 1/2" JUNCTION BOX			P52-2019

\* TO ORDER, SUPPLY MACHINE MODEL AND SERIAL NUMBER ( 62 )

# ST-30 BOOSTER

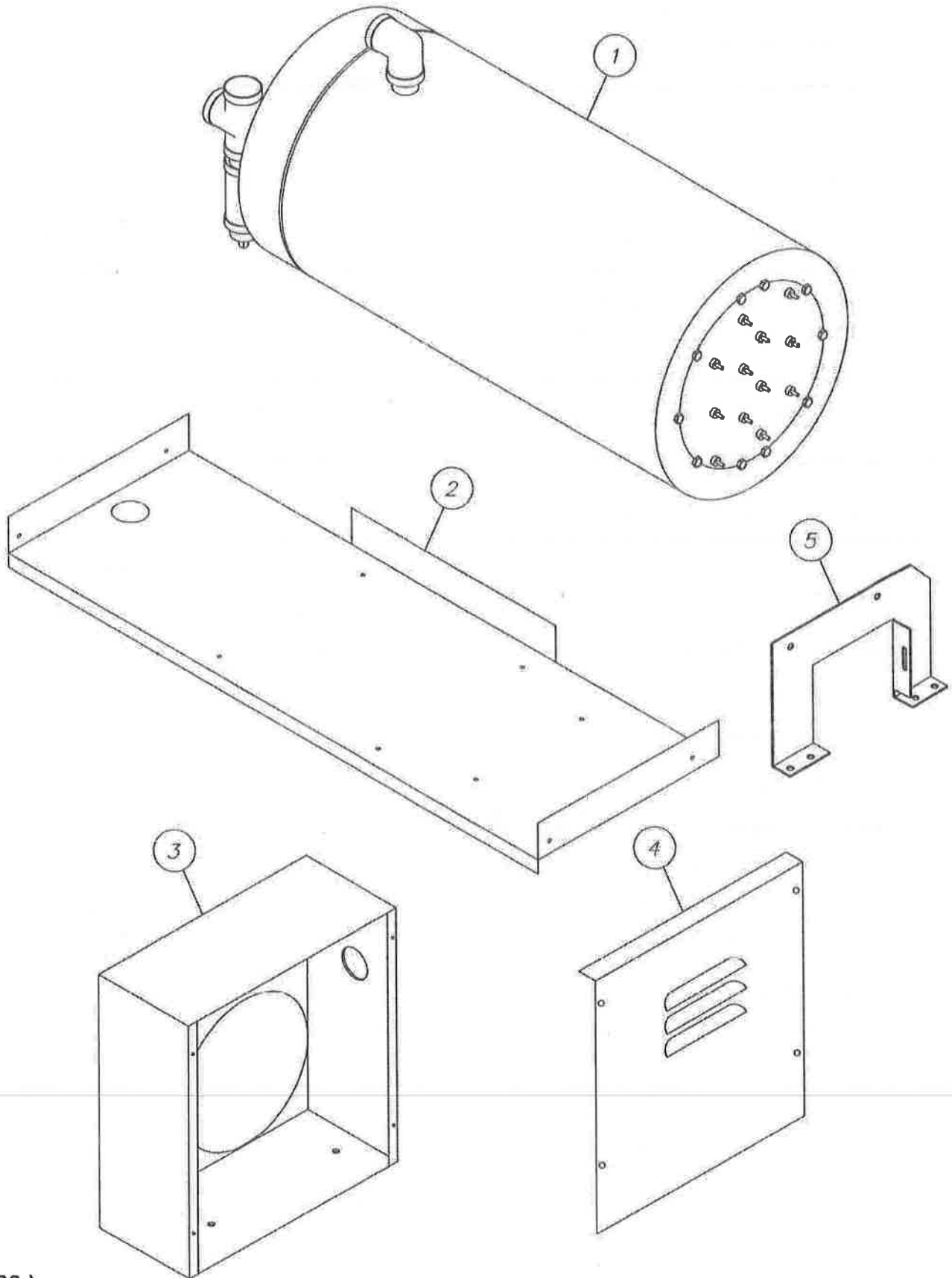

# ST-30 BOOSTER

ITEM	DESCRIPTION	REMARKS	QTY	PART#
1	BOOSTER, TANK/HEATER ASSY 30KW 208V			P64-7127
	BOOSTER, TANK/HEATER ASSY 30KW 240V			P64-7128
	BOOSTER, TANK/HEATER ASSY 30KW 480V			P64-7134
2	FRAME, 30KW BOOSTER			A10-7101
3	J BOX, 30KW			A10-7102
4	COVER, J BOX 30KW			A10-7103
5	SUPPORT LEG, TOP MOUNTED INTEGRATED BOOSTER			B10-7137
	HOSE, WATER, BRAIDED, SST 1/2" X 22"			P51-7139
	208v Element & install kit	Hobart #		00-913102-00140
	240v Element & install kit	Hobart #		00-913102-00141
	480v Element & install kit	Hobart #		00-913102-00142

\* TO ORDER, SUPPLY MACHINE MODEL AND SERIAL NUMBER ( 64 )

# COMMON PLUMBING PARTS

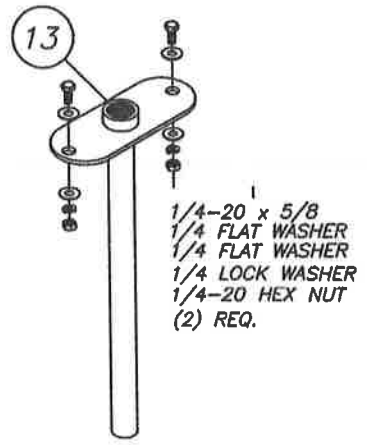
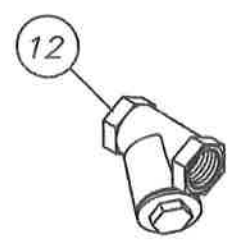
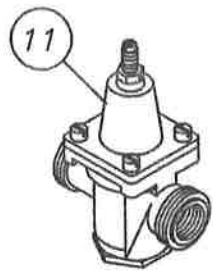
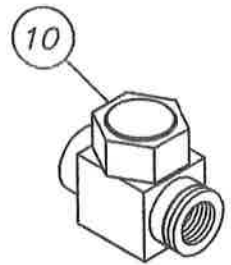
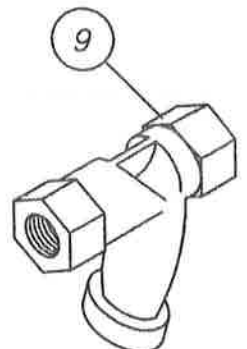
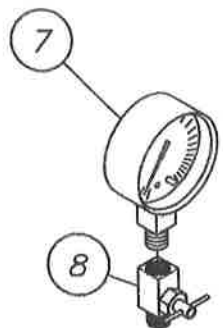
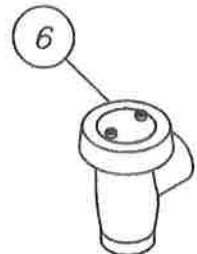
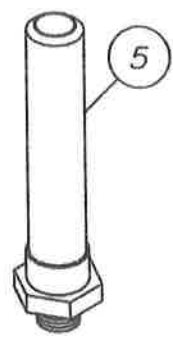
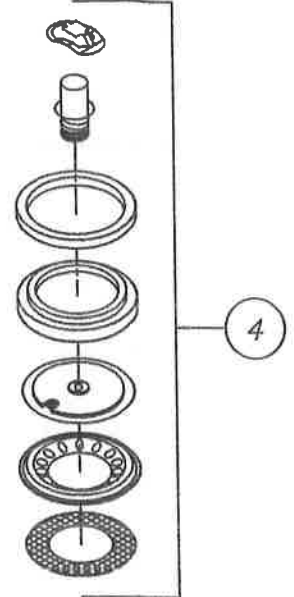
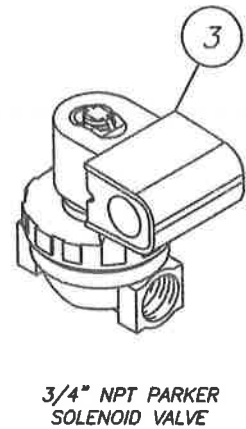
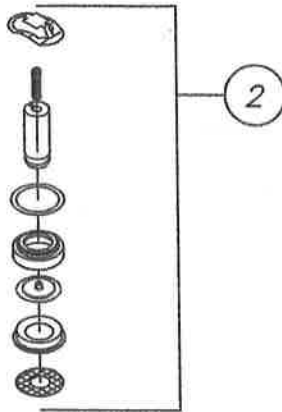
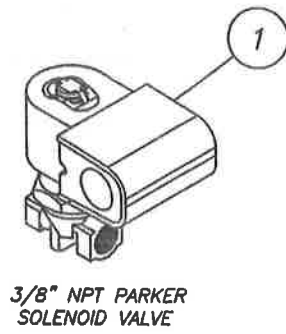

## COMMON PLUMBING

ITEM	DESCRIPTION	REMARKS	QTY	PART#
1	VALVE, 3/8 120V PARKER ASSEMBLY	FILL SOLENIOD VALVE		P54-6570
	VALVE, 3/8 ONLY			P54-6518
	COIL, 120V ONLY			P54-6248
2	REPAIR KIT, 3/8 VALVE			P54-7002
3	VALVE, 3/4 120V PARKER ASSEMBLY	TANK HEAT STEAM OR FILL ON INTEGRATED BOOSTER		P54-6245
	COIL, 120V ONLY			P54-6248
4	REPAIR KIT, 3/4 VALVE			P54-6247
5	SHOCKSTOP 3/4 MINI #05			P62-2250
6	VACUUM BREAKER 3/8			P62-6374
7	GAUGE PRESSURE 2-1/2 60 PSI			P65-1136
8	VALVE, NEEDLE STR 1/4 X 1/4 MIP X FIP			P68-1511
9	LINE STRAINER BRASS 3/4			P63-1115
10	STEAM TRAP TD52L 1/2			P61-1169
11	VALVE PRESS REDUCING 3/4 WATER			P62-1166
12	CHECK VALVE 1/2 NIBCO STM SUP			P62-6847
13	FILL TUBE ASSY 5/8			A10-6771

**\* TO ORDER, SUPPLY MACHINE MODEL AND SERIAL NUMBER (66)**

# DRAIN & OVERFLOW ASSEMBLY

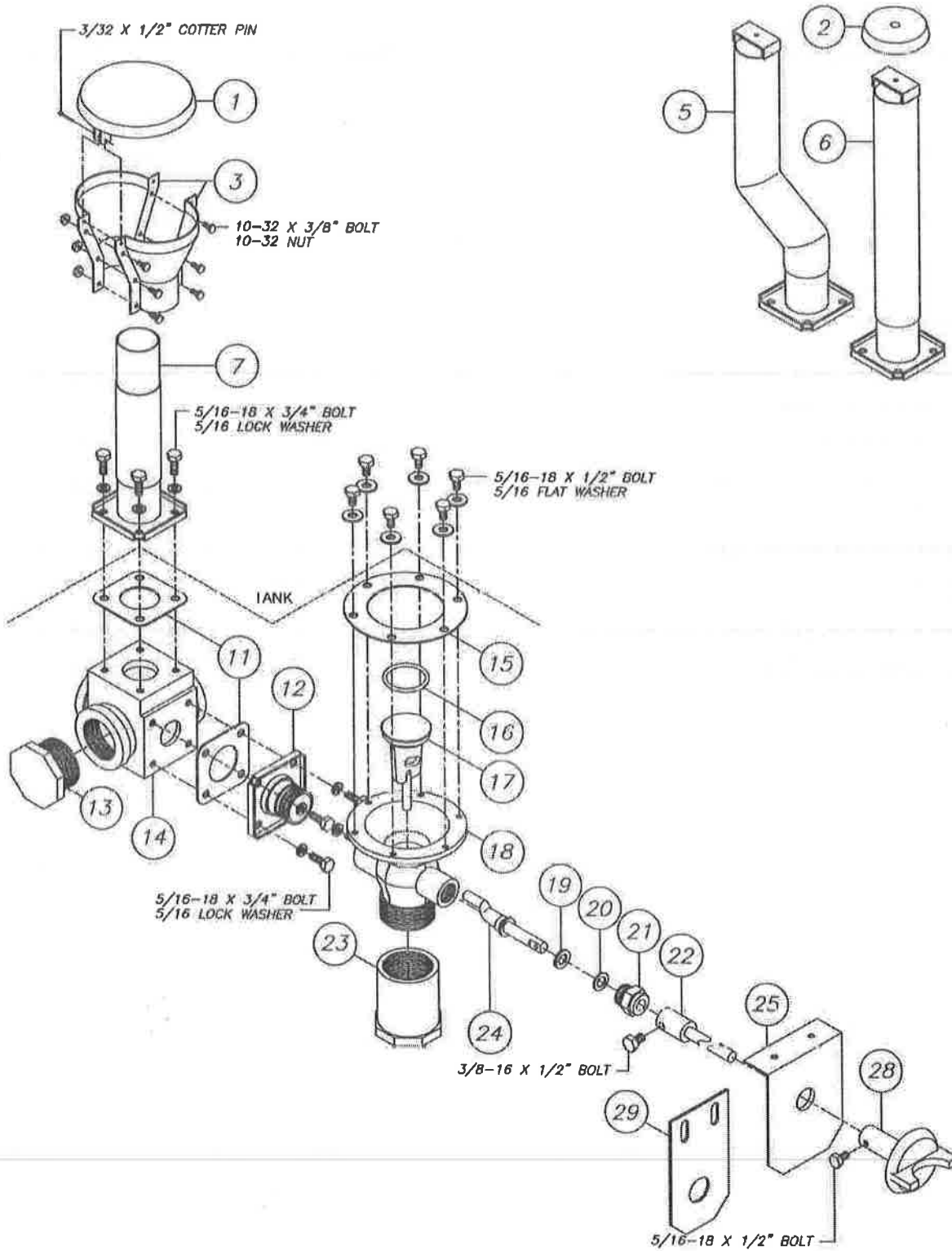



## DRAIN & OVERFLOW ASSEMBLY

ITEM	DESCRIPTION	REMARKS	QTY	PART#
1	FUNNEL COVER			A10-1874
2	CAP, OVERFLOW TUBE			A10-1508
3	FUNNEL OVERFLOW ASSM. (INCLUDES BOTH HALVES & HARDWARE			A10-1873
5	ASSEMBLY DRAIN TUBE UNIV.	ER-64. ER-86 OR 94 WASH TANK ONLY		A10-6184
	ASSEMBLY, 13" RINSE TANK OVERFLOW	ER-86 OR 94 RINSE TANK ONLY		A10-7072
6	OVERFLOW SCRAP TANK STAND PIPE	SCRAPPER		A10-2273
7	OVERFLOW STAND PIPE TO FUNNEL	ER-44, 66 OR 76		A10-1889
11	GASKET "U" FLANGE		2	A57-1114
12	ADAPTOR ASSM. DRAIN TO OVERFLOW			A10-3305
13?	PVC PLUG 2"; OVERFLOW			P68-1698
14	TEE OVERFLOW DRAIN BOX #97			B10-1871
15	GASKET "D" WASTE VALVE FLANGE			A57-1194
16	ORING #327 VITON; FOR DRAIN VALVE POPPET			P57-1057
17	DRAIN VALVE POPPET WITH ORING			A44-1196
18	WASTE VAVLE BODY			C10-1193
19	PACKING RING; DRAIN VALVE			P57-6253
20	PACKING WASHER BRASS; DRAIN VALVE			A10-1183
	PACKING WASHER & RING KIT	INCLUDES 19 & 20		A10-6254
21	PACKING NUT BRASS; DRAIN VALVE			A10-1182
22	SHFT CRSS DRN VLV 12-1/2 " LONG			B10-2909
23?	PVC CAP 2"; DRAIN VALVE			P68-2066
24	ECCENTRIC ARM; DRAIN VALVE			A10-1184
25	PLATE GUIDE SCRAPPER DRAIN VALVE	SCRAPPER		A10-2282
28	HANDLE; DRAIN VALVE			B10-1888
29	BRACKET; DRAIN VALVE HANDLE FLAT ER			A10-6998
	HOSE 3/4" ID 2 PLY NITRILE FOOD (CARRY OVER)	BY FOOT		P68-6981
	OVERFLOW DRAIN TEE ASSEMBLY	(INCLUDES: 1,3,7,11,12 & 14)		A10-1875
	DRAIN VALVE COMPLETE ASSEMBLY	(INCLUDES: 16-21 & 24)		A10-1251
	WASTE VALVE COMPLETE ASSEMBLY	(INCLUDES: 11,12,14, 16-21 & 24)		A10-5265

\* TO ORDER, SUPPLY MACHINE MODEL AND SERIAL NUMBER ( 68 )

# TEMPERATURE GAUGE ASSEMBLY

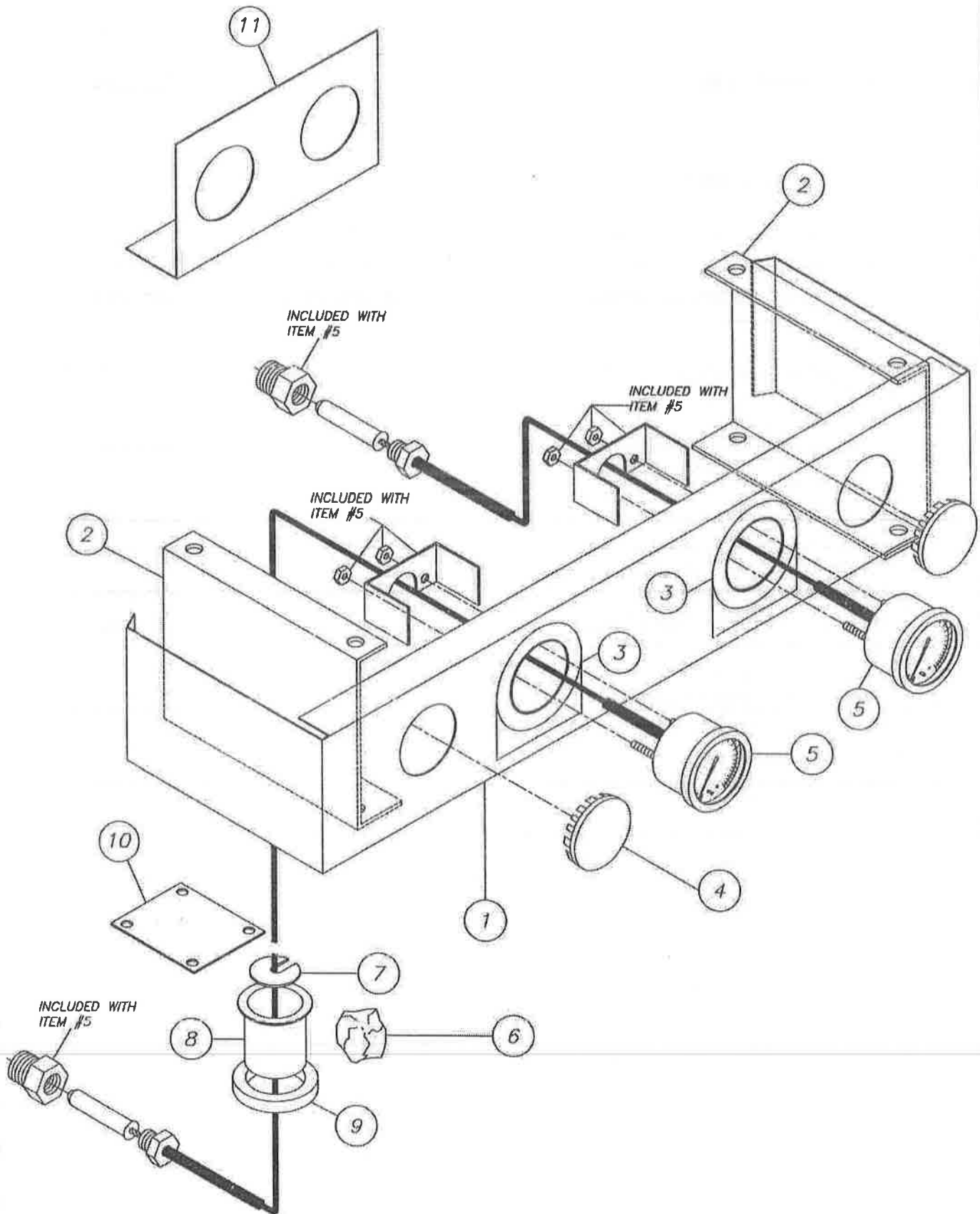

## TEMPERATURE GAUGE ASSEMBLY

ITEM	DESCRIPTION	REMARKS	QTY	PART#
1	DASHBOARD, 4 HOLE			B10-2725
2	BRACKET, MOUNTING			A10-2705
3	DECAL, TEMP GAUGE POWER SCRAPPER	110-140		A69-1454
	DECAL, TEMP GAUGE POWER WASH 160-175	ER-44, 66S, 76S		A69-1457
	DECAL, TEMP GAUGE POWER WASH 150-165	ER-64, 86S, 94S		A69-1456
	DECAL, TEMP GAUGE POWER RINSE 165-170	ER-64, 86S, 94S		A69-6328
	DECAL, TEMP GAUGE FINAL RINSE 180-195			A69-1460
4	PLUG, CAP 2" CHROME PLATED			P67-2619
5	GAUGE, TEMPERATURE			P65-1135
	GAUGE, TEMPERATURE W/ 8' LONG LEAD			P65-5948
6	PUTTY, SEALING (DUM-DUM)			P57-1878
7	WASHER, SEALING CUP			A10-2155
8	CUP, SEALING FOR GAUGE			A10-2150
9	RING, NEOPREME			A57-2156
10	PLATE, BLOCK OFF TEMP GAUGE			A10-5271
11	BRACKET, DUAL GAUGE S.S.	2 COMPARTMENT BOX SETUP W/OUT DASHBOARD		B10-2398
ER-44 2 GAUGES: WASH & FINAL RINSE				
ER-64 3 GAUGES: WASH, POWER RINSE & FINAL RINSE				
ER-66 & ER-76 3 GAUGES: POWER SCRAPPER, WASH & FINAL RINSE				
ER-86 & ER-94 4 GAUGES: POWER SCRAPPER, WASH, POWER				

\* TO ORDER, SUPPLY MACHINE MODEL AND SERIAL NUMBER ( 70 )

# CONTROL BOX

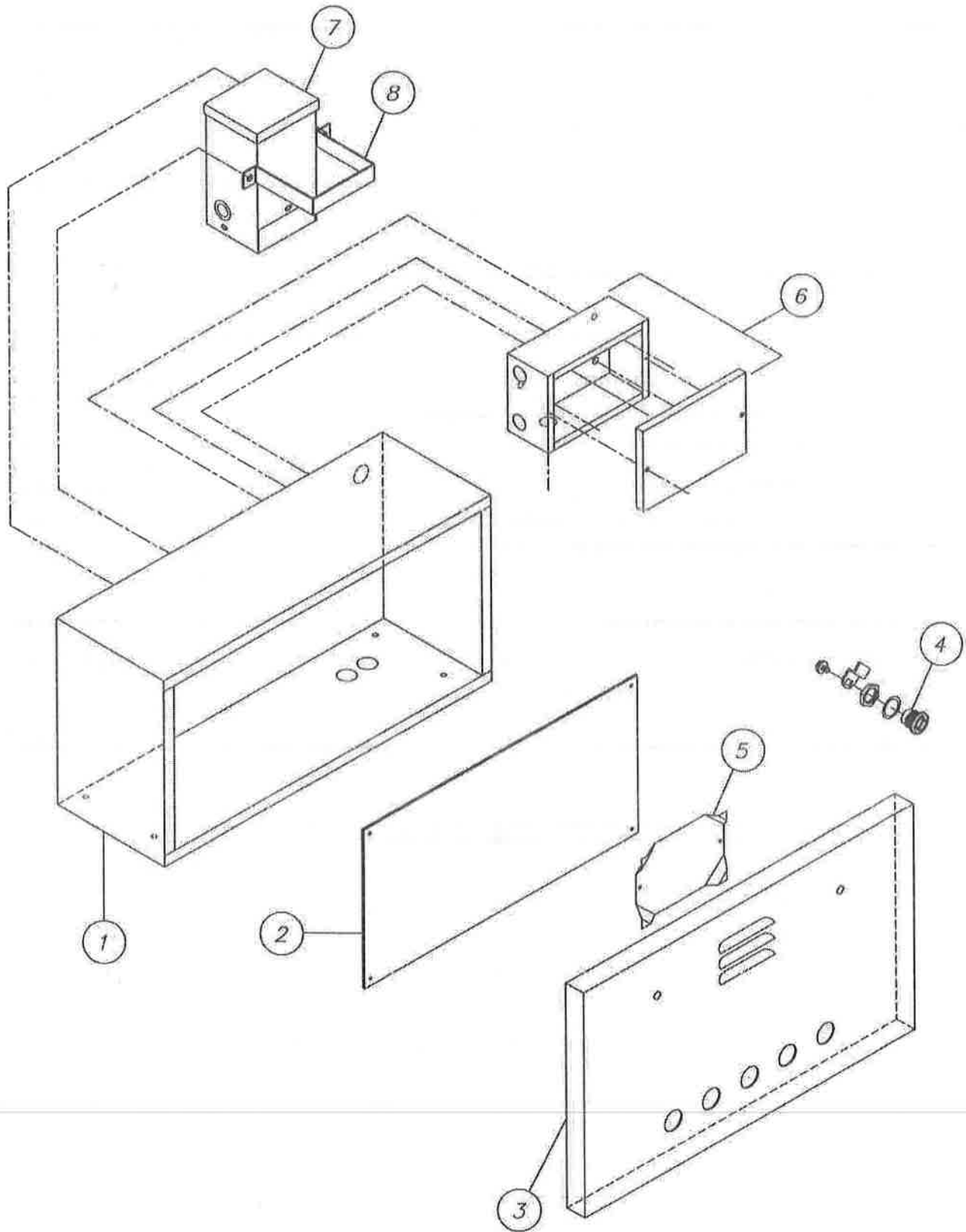

## CONTROL BOX

ITEM	DESCRIPTION	REMARKS	QTY	PART#
1	BOX, 24" ELECT CONTROL	ER-44	1	C10-5523
	BOX, 30" ELECT CONTROL		1	A10-4456
2	PLATE, CTRL MTG 10 X 20		1	A10-4507
3	DOOR, CTRL PNL 24" 5 HOLE		1	A10-3765
4	LATCH SLOTTED		2	P69-6679
5	SPLASH SHIELD SML TOP CONTRL BOX		1	F99-0310
6	FAN CONTACTOR BOX ASSEMBLY		1	A10-5703
7	TRANSFORMER .500KVA 240/480PRY		1	P53-1750
8	TRANSFORMER STRAP CONV SMALL		1	A10-6744

\* TO ORDER, SUPPLY MACHINE MODEL AND SERIAL NUMBER ( 72 )

# 60" CONTROL BOX

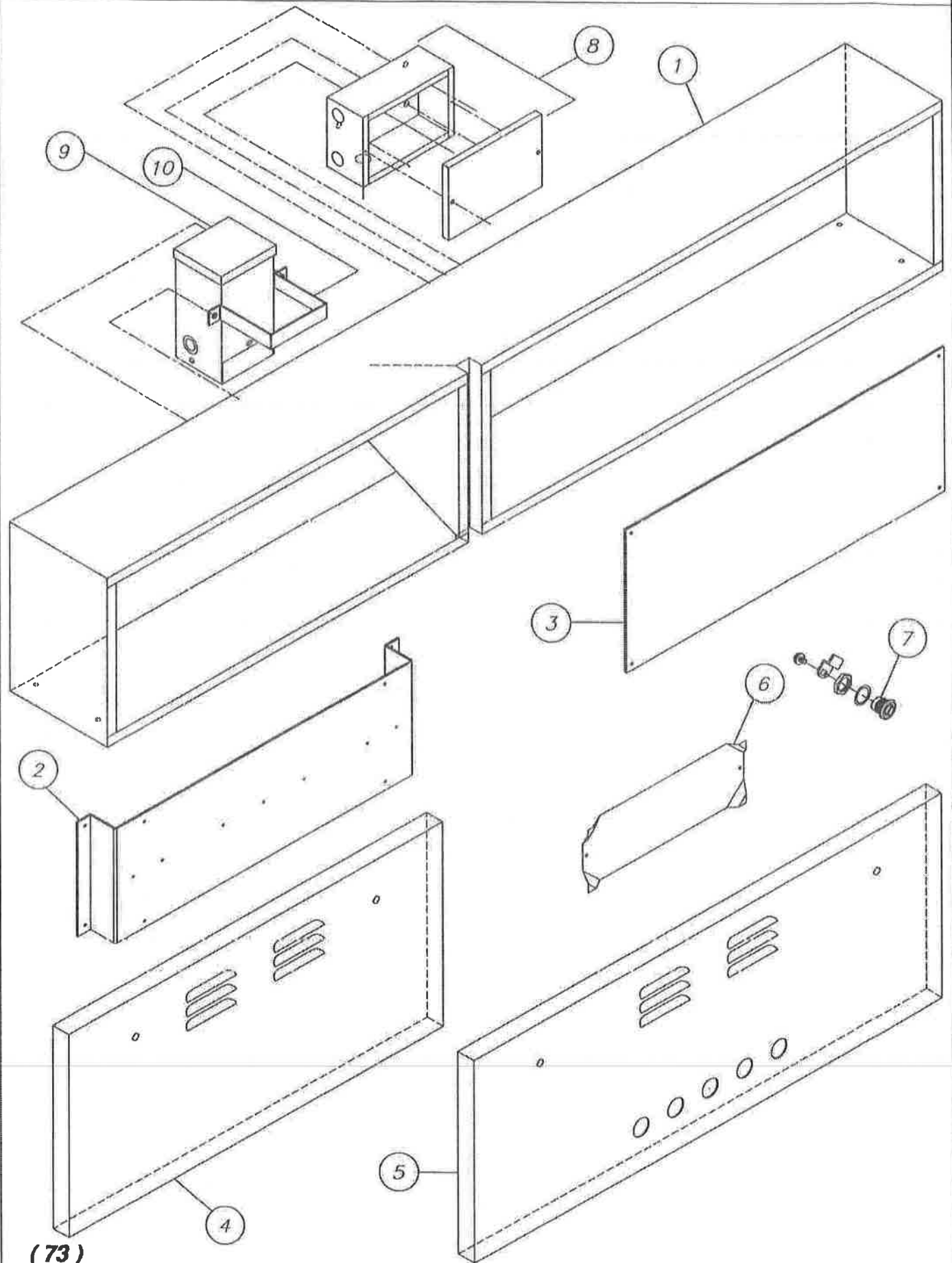



# CONTROL BOX COMPONENTS

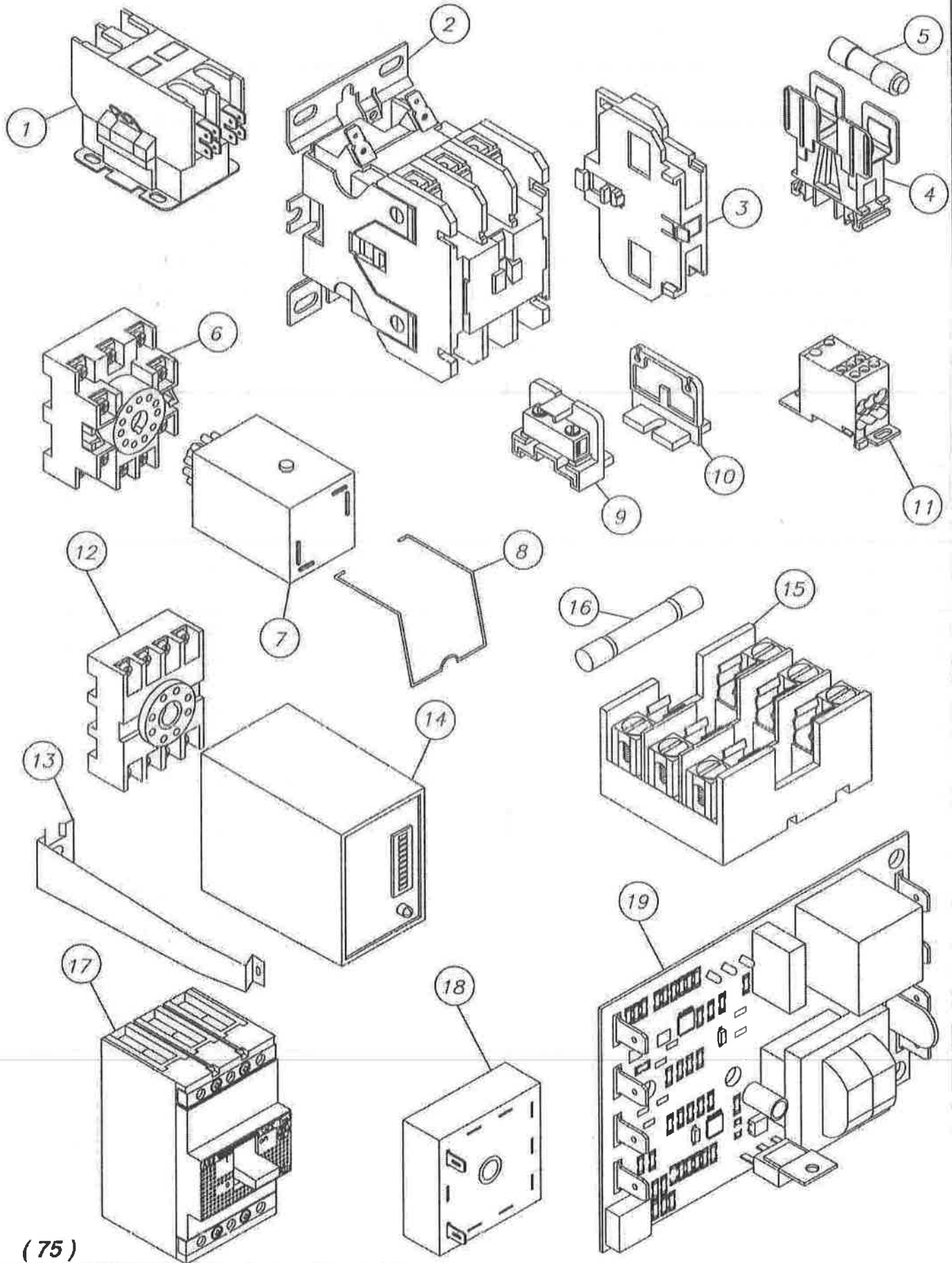



## CONTROL BOX COMPONENTS

ITEM	DESCRIPTION	REMARKS	QTY	PART#
1	CONTACTOR 2 POLE 115V. 20/30 AMP	EXHAUST FAN		P47-6044
2	CONTACTOR 3 POLE 115V	30/40 AMP		P47-5500
	CONTACTOR 3 POLE 115V	50/65 AMP		P47-6207
3	AUXILIARY CONTACTOR 1 N/O			P47-5517
4	TERMINAL NDNF1 FUSE BLOCK			P52-5996
5	FUSE KLKR 3 AMP CLASS CC			P52-1854
	FUSE KLKR 5 AMP CLASS CC			P52-2192
6	RELAY SOCKET			P47-2465
7	RELAY 120V 10 AMPS 3 POLE			P47-2464
8	CLIP RELAY HOLD DOWN			P47-2466
9	TERMINAL BLOCK			P52-1099
10	TERMINAL BLOCK END MARATHON			P52-1100
11	BLOCK, PWR DISTRIBUTION			P52-6294
12	SOCKET RELAY NDS-8			P47-6352
13	CLIP SOCKET			P47-6353
14	TIMER ADJ. 512 SEC 110 VOLT			P46-1744
15	FUSE HOLDER			P47-6800
16	FUSE SLC 35 AMP CLASS G	TIME DELAY		P52-1748
	FUSE SLC 40 AMP CLASS G	TIME DELAY		P52-5843
	FUSE SLC 50 AMP CLASS G	TIME DELAY		P52-6392
	FUSE SLC 60 AMP CLASS G	TIME DELAY		P52-1749
17	CIRCUIT BREAKER, 15 AMP 3 POLE 480V. ABB			P48-6261
	CIRCUIT BREAKER, 30 AMP 2/3 POLE 480V. ABB			P48-6263
18	RELAY PARKFR FLOAT			P47-6993
19	SOLID STATE THERMOSTAT 115V			P42-6985
	WIRE 10086B-12112 UL/CSA BLK			P45-2175
	WIRE 8 STRANDED THHN BLK			P45-2182
	WIRE 6 STRANDED THHN BLK			P45-2183

\* TO ORDER, SUPPLY MACHINE MODEL AND SERIAL NUMBER ( 76 )

# FILL SWITCH ASSEMBLIES NON LED

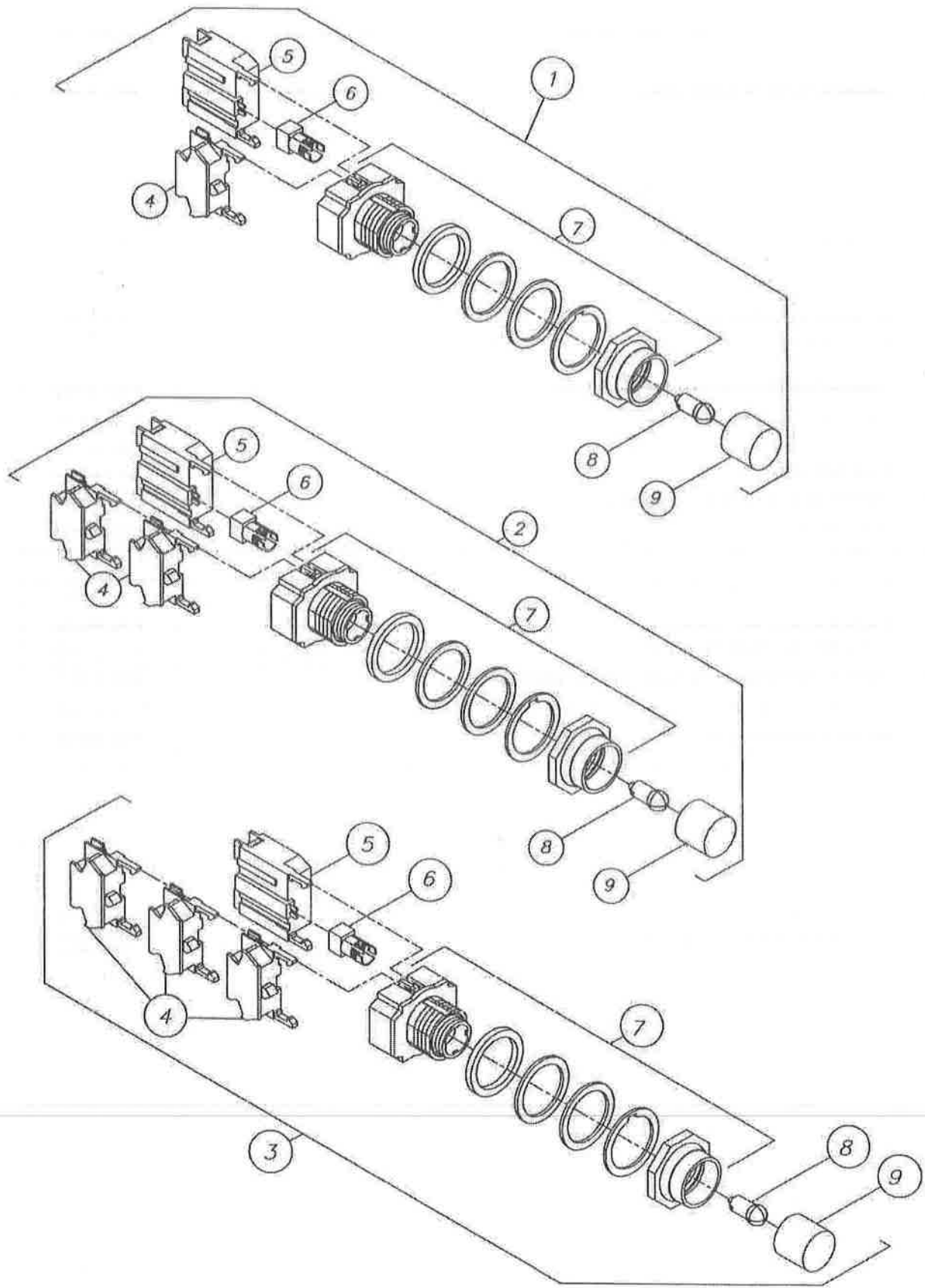

## FILL SWITCH ASSEMBLIES

ITEM	DESCRIPTION	REMARKS	QTY	PART#
1	SWITCH, FILL COMPLETE ASSEMBLY	1 TANK		NLA
2	SWITCH, FILL COMPLETE ASSEMBLY	2 TANK		NLA
3	SWITCH, FILL COMPLETE ASSEMBLY	3 TANK		NLA
4	N/O A BLOCK	GREEN		P49-1303
5	TRANSFORMER 110 VOLT TO 6.3 VOLT	BLACK		NLA
6	LAMP HOLDER SHORT			P49-1319
	LAMP HOLDER LONG	SOME 3 TANK		P49-1918
7	PUSH BUTTON ILLUMINATED MOMENTARY			P49-1310
8	LAMP #51			P49-1322
9	GREEN LENS			P49-1312

\* TO ORDER, SUPPLY MACHINE MODEL AND SERIAL NUMBER ( 78 )

# FILL SWITCH ASSEMBLIES LED

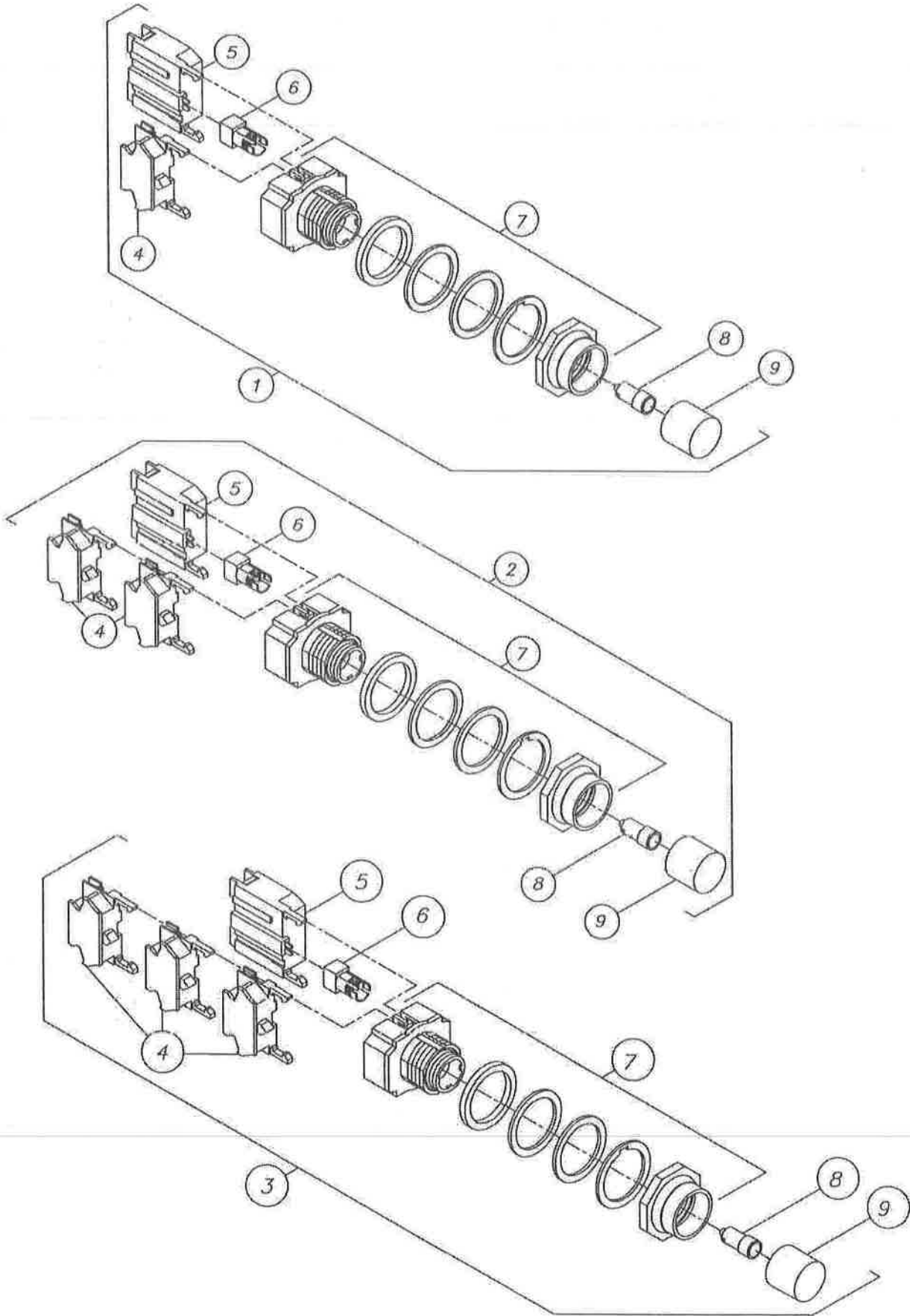

## FILL SWITCH ASSEMBLIES LED

ITEM	DESCRIPTION	REMARKS	QTY	PART#
1	SWITCH, FILL COMPLETE ASSEMBLY	1 TANK		A10-4517
2	SWITCH, FILL COMPLETE ASSEMBLY	2 TANK		A10-1933
3	SWITCH, FILL COMPLETE ASSEMBLY	3 TANK		A10-3734
4	N/O A BLOCK	GREEN		P49-1303
5	ADAPTOR FULL VOLT LED BULB	BLACK		P49-7129
6	LAMP HOLDER SHORT			P49-1319
	LAMP HOLDER LONG	SOME 3 TANK		P49-1318
7	PUSH BUTTON ILLUMINATED MOMENTARY			P49-1310
8	BULB LED 120V GREEN			P49-7130
9	GREEN LENS			P49-1312

**\* TO ORDER, SUPPLY MACHINE MODEL AND SERIAL NUMBER ( 80 )**

# TANK OR BOOSTER HEAT SWITCH ASSM.

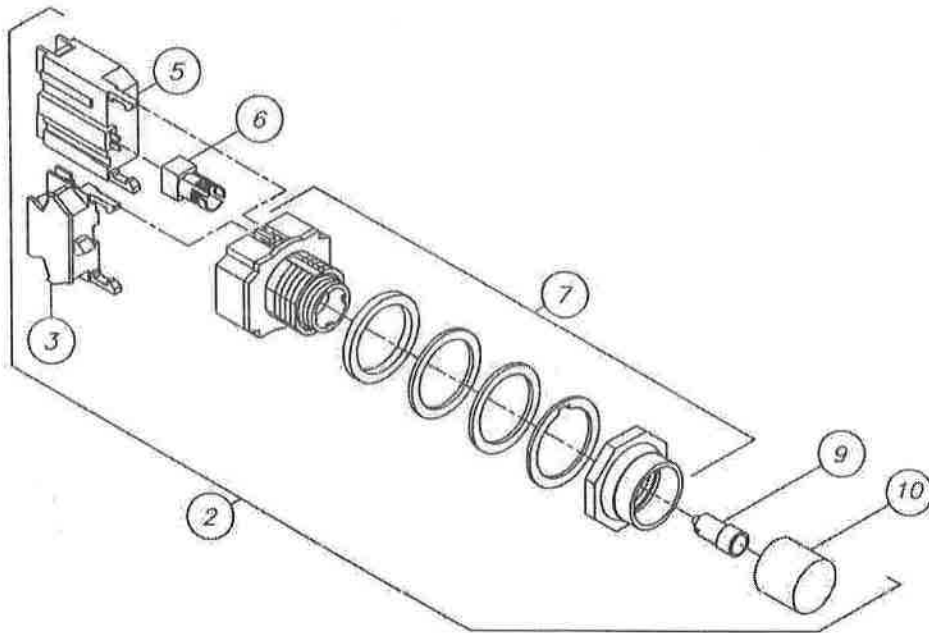
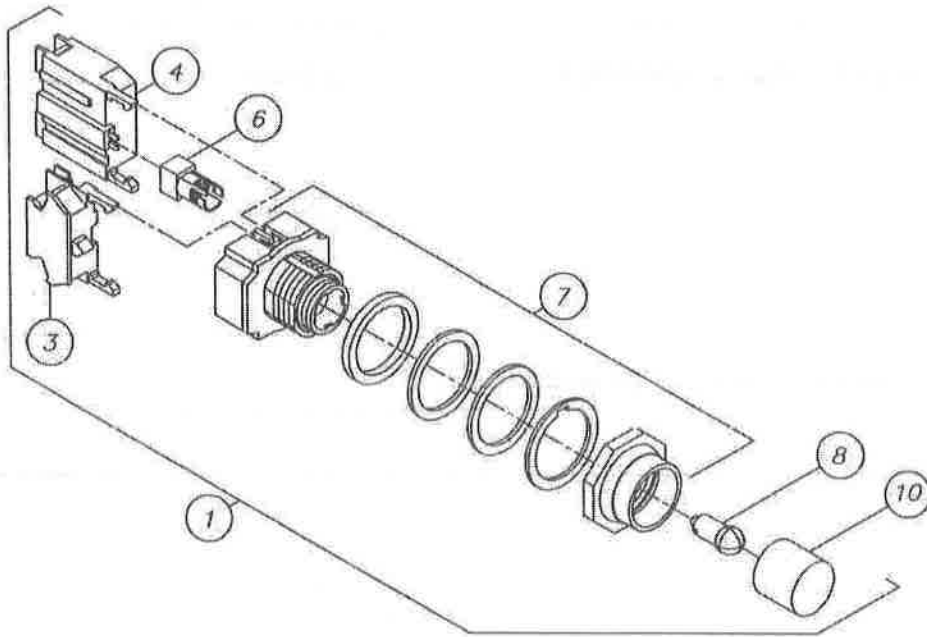



# SWITCH ASSEMBLIES

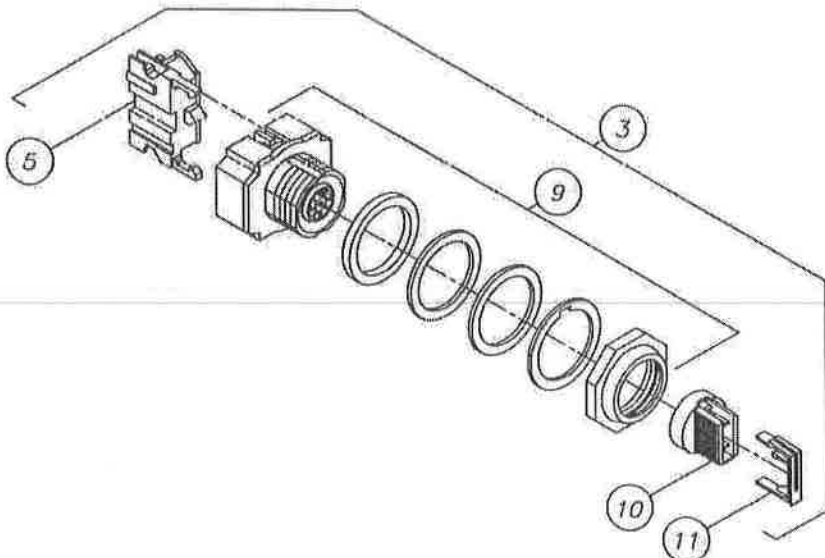
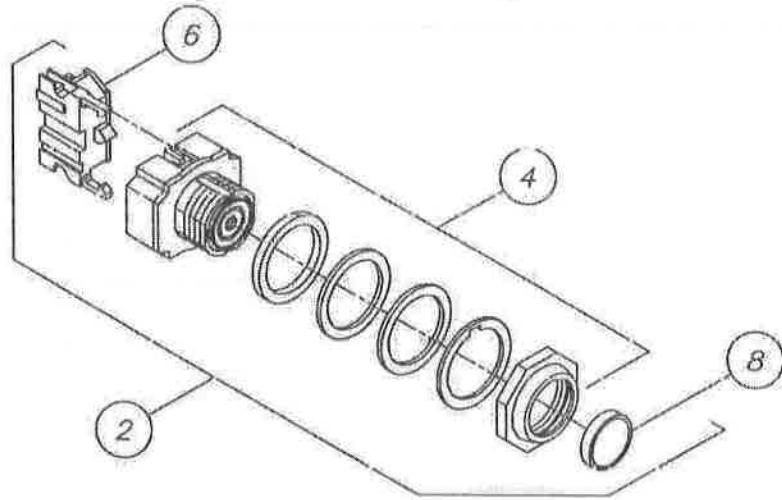
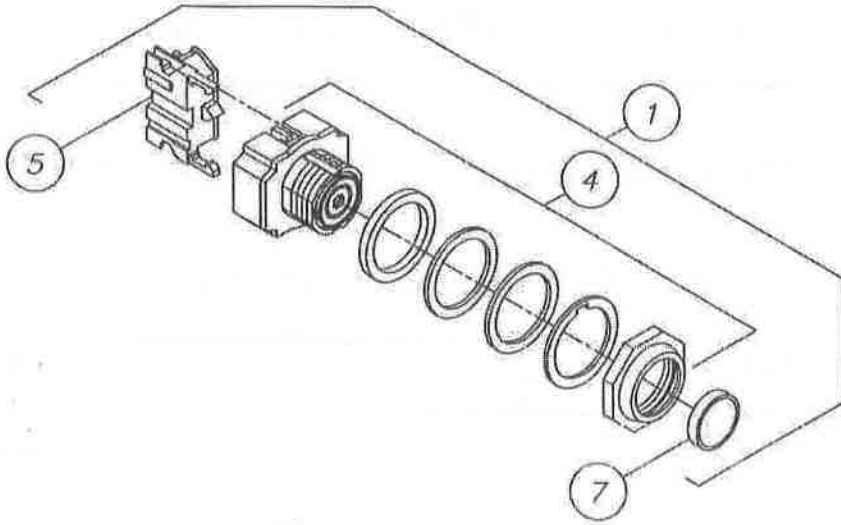



## SWITCH ASSEMBLIES

ITEM	DESCRIPTION	REMARKS	QTY	PART#
1	SWITCH, START OR RESET COMP. ASSM.			A10-1936
2	SWITCH, STOP COMPLETE ASSEMBLY			A10-1937
3	SWITCH ON/OFF COMPLETE ASSM.			A10-1930
4	PUSH BUTTON OPERATOR			P49-1305
5	N/O A BLOCK	GREEN		P49-1303
6	N/C B BLOCK	RED		P49-1304
7	BLACK DISC CAP			P49-1314
8	RED DISC CAP			P49-1315
9	SELECTOR SWITCH 2 POSITION			P49-1306
10	BLACK KNOB			P49-1316
11	LOCK INSERT WHITE KNOB			P49-1317

\* TO ORDER, SUPPLY MACHINE MODEL AND SERIAL NUMBER ( 84 )

# TABLE LIMIT SWITCH ASSEMBLY

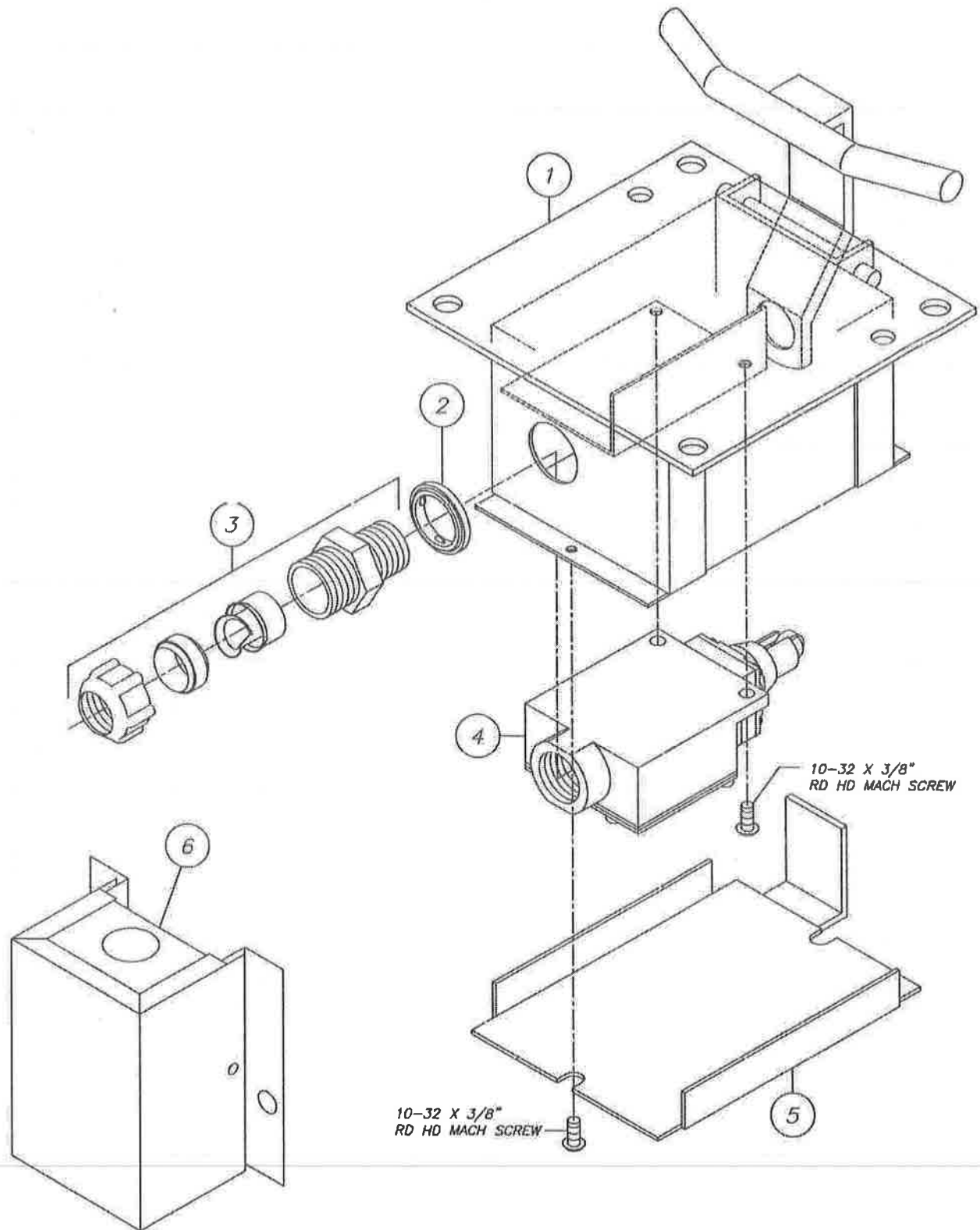

## TABLE LIMIT SWITCH ASSEMBLY

ITEM	DESCRIPTION	REMARKS	QTY	PART#
1	HOUSING, TABLE LIMIT SWITCH			A10-2214
2	SEALING RING 1/2" SEALTITE			P52-1038
3	CONNECTOR STRAIGHT 3/8" SEALTITE FITTING			P52-1142
4	TABLE LIMIT SWITCH			P49-1916
5	COVER HOUSING, TABLE LIMIT SWITCH			A10-2222
6	TABLE LIMIT SWITCH TERMINAL BOX & COVER			A10-6312
	TABLE LIMIT SWITCH COMPLETE (INCLUDES ITEMS 1-5)			B10-2223

\* TO ORDER, SUPPLY MACHINE MODEL AND SERIAL NUMBER ( 86 )

# PARKER FLOATS

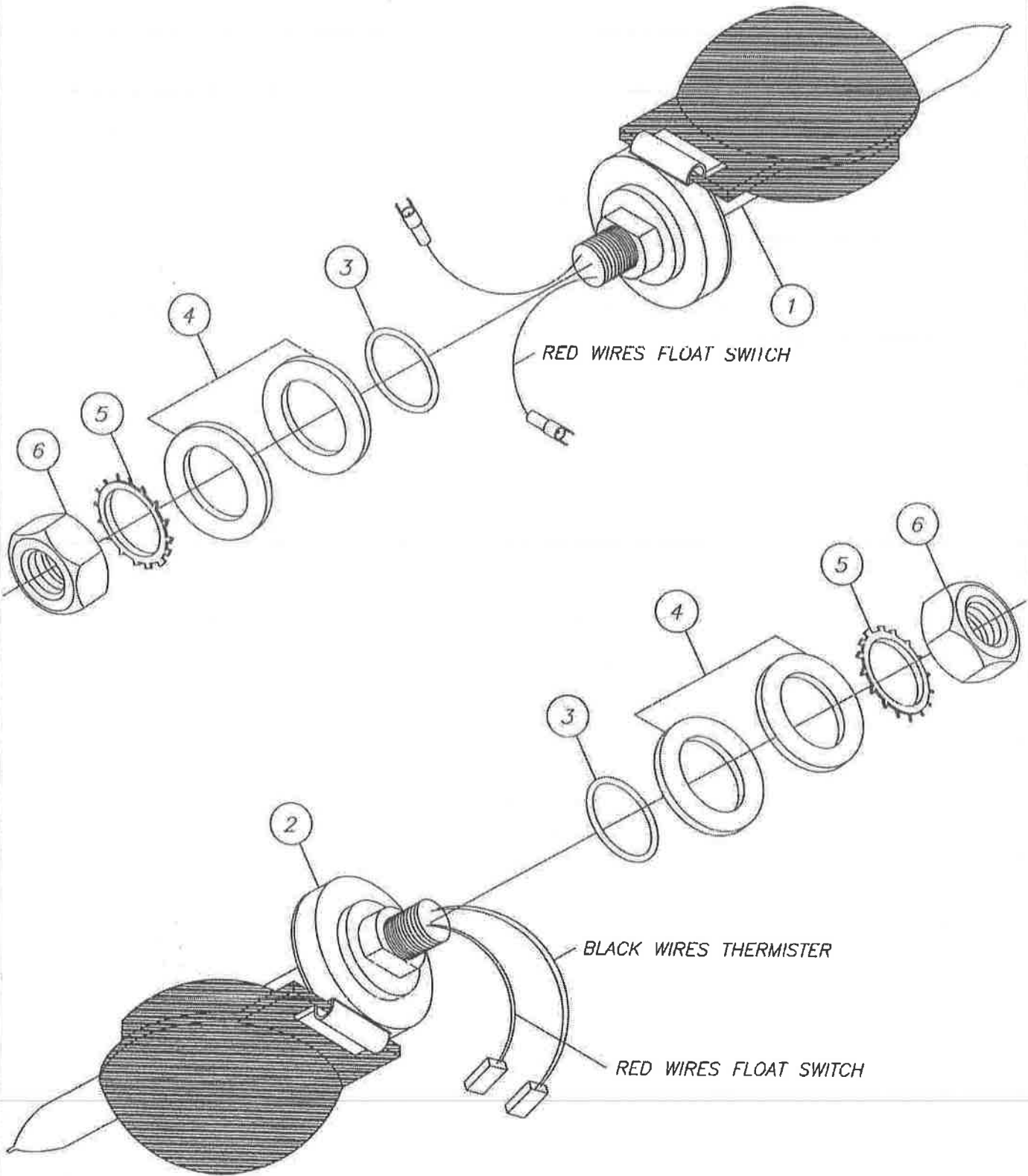



# PARKER FLOAT FILL ASSEMBLY A10-7017

8-32 SS NUT (X 2)

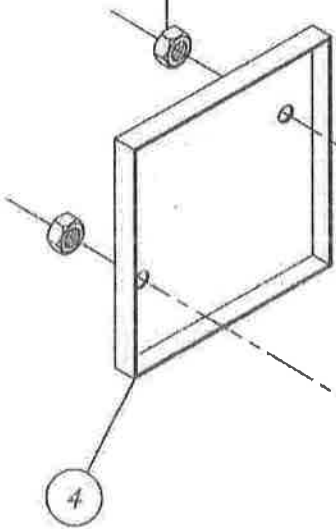

HEX SS NUT 5/16-18 (X 4)  
WASHER SS 5/16 (X 4)  
LOCK WSHR SS 5/16 (X 4)

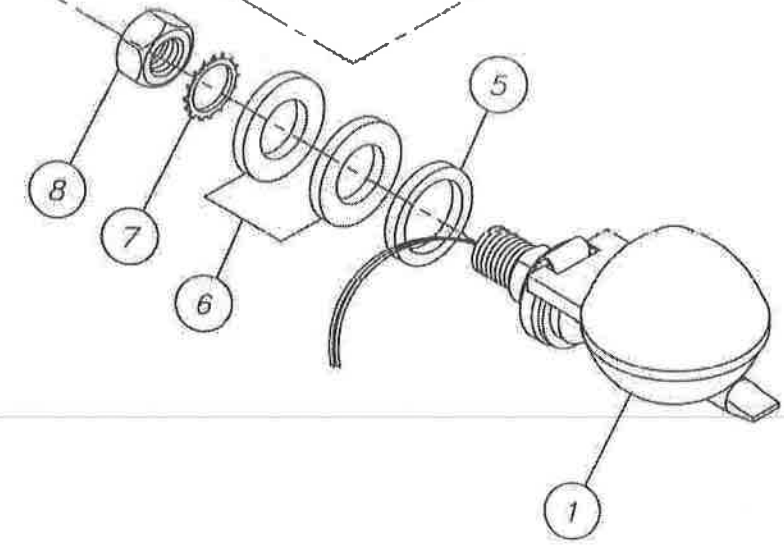
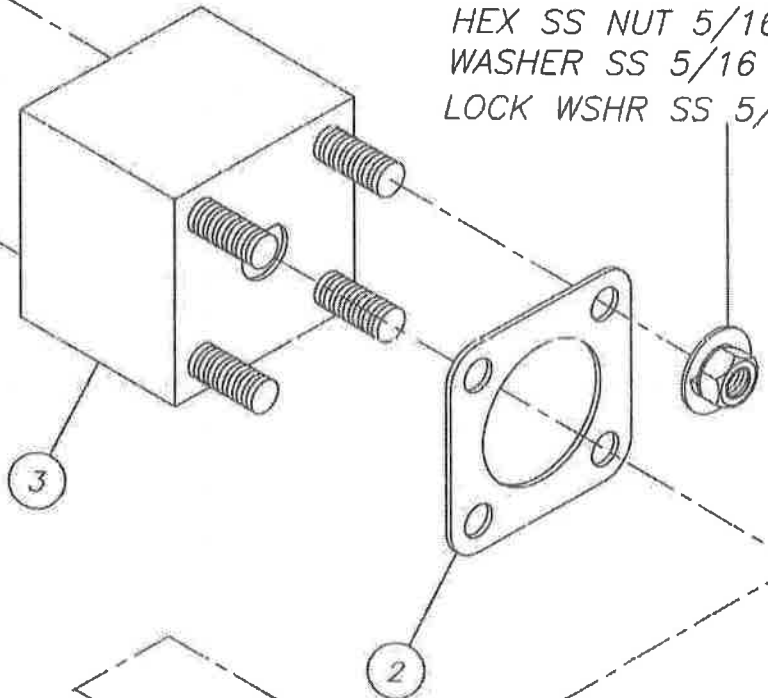

**PARKER FLOAT ASSEMBLY**

ITEM	DESCRIPTION	REMARKS	QTY	PART#
1	PROBE & FLOAT ASSY W/O THERMISTER	FILL FLOAT	1	P49-6988
2	GASKET, "2840" FLOAT SWITCH MTG		1	A57-1419
3	FLOAT SWITCH HOUSING ASSY FILL		1	A10-7008
4	FLOAT SWITCH COVER		1	A10-1424
5	"O" RING		1	P57-6990
6	WASHER		2	P67-6991
7	STAR WASHER		1	P67-6992
8	NUT		1	P67-6989

\* TO ORDER, SUPPLY MACHINE MODEL AND SERIAL NUMBER ( 90 )









The Stero Company  
1758 Corporate Circle  
Petaluma, CA 94954

(800) 762-7600

Toll free to Parts & Service

(877)-762-3200